

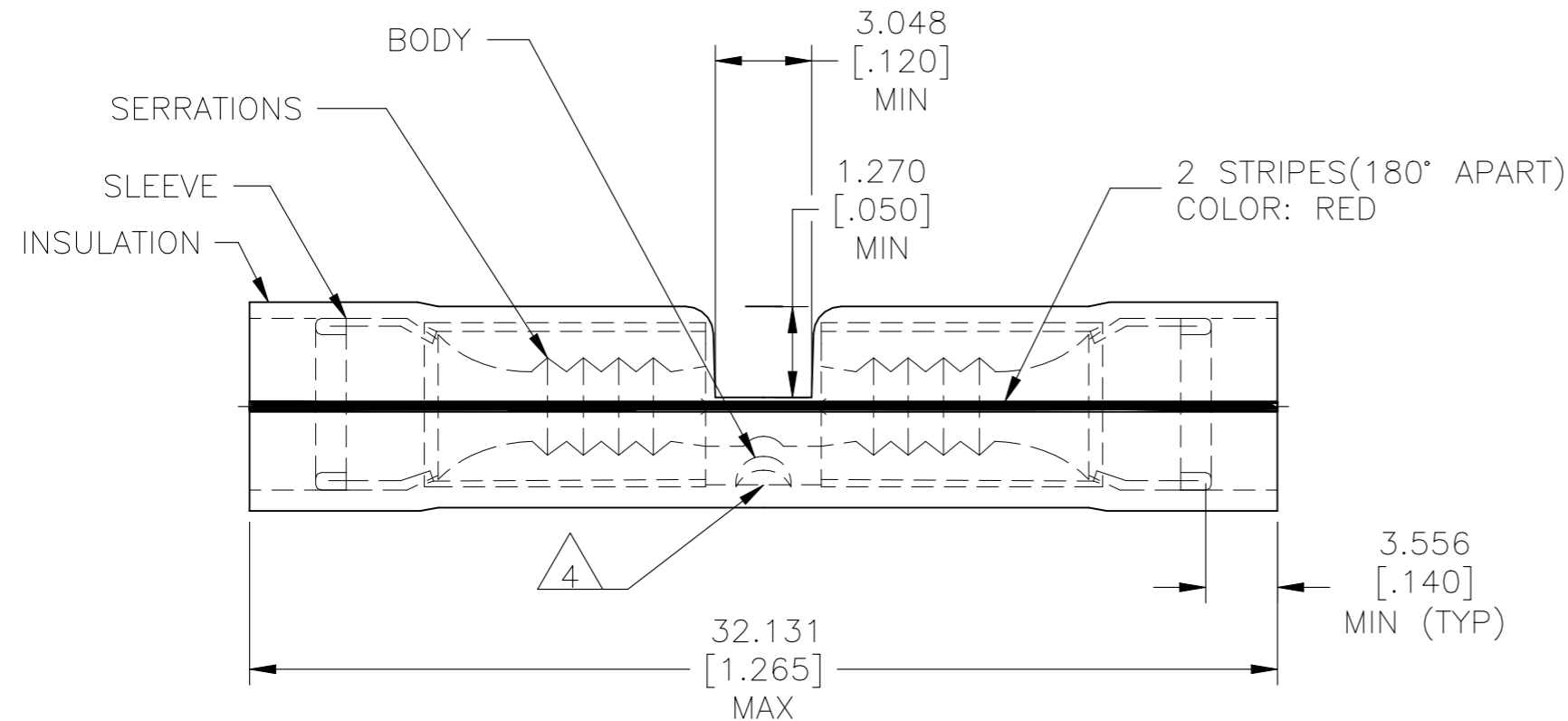

P	LTR	DESCRIPTION	DATE	DWN	APVD
	K3	REV PER ECN-22-156403	03JUN2022	RK	CSD

 WIRE RANGE
22-16 AWG STRANDED



- 1 WIRE INSULATION  $\phi 2.032[\phi .080]$  TO  $\phi 3.175[\phi .125]$ .
- 2 FINISH:  
 BODY AND SLEEVE: TIN/LEAD (93-7) PLATE PER ASTM B545.(3% MIN LEAD CONTENT)  
 INSULATION: COLOR-NATURAL.
- 3 MATERIAL:  
 BODY AND SLEEVE: COPPER PER ASTM B152  
 INSULATION: PVF<sup>2</sup>
- 4 STAMP AMP 22-18\* APPROX AS SHOWN.  
 22-16 TERMINALS ARE STAMPED  
 22-18 IN ACCORDANCE WITH MILITARY SPEC SAE AS 7928.  
 COMMERCIAL WIRE RANGE IS 22-16.

-	2500	ON TAPE	53548-2
M7928/6-3 CLASS 1	1000	LOOSE PIECE	53548-1
MILITARY PART NUMBER & CLASS	QTY	PACKAGE TYPE	PART NO.

<b>AMP INCORPORATED</b> <b>CUSTOMER SERVICE SYSTEMS</b>		MAX RECOMMENDED OPERATING TEMPERATURE: 150°C [302°F]	THIS DRAWING IS A CONTROLLED DOCUMENT.		DWN S.S. GOULDEN 9-28-93 CHK R. HERSEY 9-28-93 APVD M ELLIS 9-28-93 PRODUCT SPEC APPLICATION SPEC 114-2157 WEIGHT -	 TE Connectivity			
FOR ADDITIONAL PRODUCT INFORMATION OR COPIES OF DRAWINGS AND TECHNICAL DOCUMENTS PRODUCT INFORMATION CENTER 1-800-522-6752	FOR APPLICATION TOOLING ASSISTANCE CENTER TOOLING INFORMATION 1-800-722-1111	VOLTAGE RATING: -	DIMENSIONS: mm [INCHES]	TOLERANCES UNLESS OTHERWISE SPECIFIED: 0 PLC ± - 1 PLC ± - 2 PLC ± - 3 PLC ± 0.127[.005] 4 PLC ± - ANGLES ± -	NAME SPLICE, BUTT, PVF <sup>2</sup> , P.I.D.G., WIRE SIZE: 22-16 AWG	SIZE A3	CAGE CODE 00779	DRAWING NO C-53548	RESTRICTED TO -
FOR ORDER ENTRY 1-800-526-5142	THIS DRAWING IS A CONTROLLED DOCUMENT FOR AMP INCORPORATED. IT IS SUBJECT TO CHANGE AND THE CONTROLLING ENGINEERING ORGANIZATION SHOULD BE CONTACTED FOR THE LATEST REVISION.		MATERIAL 3	FINISH 2	CUSTOMER DRAWING	SCALE 1:1	SHEET 1 OF 1	REV K3	