



Metal Oxide Varistor

G series Varistor

Series/Type: G14/20 series
Ordering code: Z62000Z2310Z xx
Date: 2022-09-30
Version: Preliminary 2 (only for prototype sample test, not ready for series production)

Applications

- Solar
- Power Supplies
- LED Applications
- Charges
- Surge Protection Devices
- White Goods
- Communications

Construction

- Round varistor in series with arrester, leaded
- Coating: epoxy , flame-retardant to UL 94 V-0
- Terminals: tinned copper wire, metal compound wire

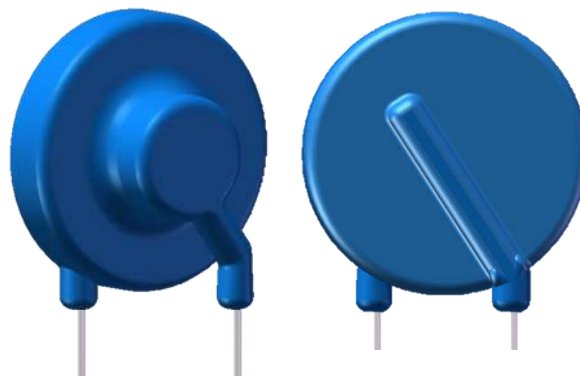

Features

- Hybrid design (GDT+MOV)
- Low leakage
- RoHS complaint

General technical data

Climatic category to IEC 60068-1	40 / 85 / 56
Operating temperature	-40...+85 °C
Storage temperature	-40...+85 °C
Coating material	UL94-V0
Application altitude	<2000 m

Nomenclature

- G = Series designation
 14/20 = Rated disk diameter (mm)
 K = Tolerance of V_v at 1 mA: $\pm 10\%$
 150 ... 320 = Max. operating AC voltage

Dimensional drawing in mm

G14 series:

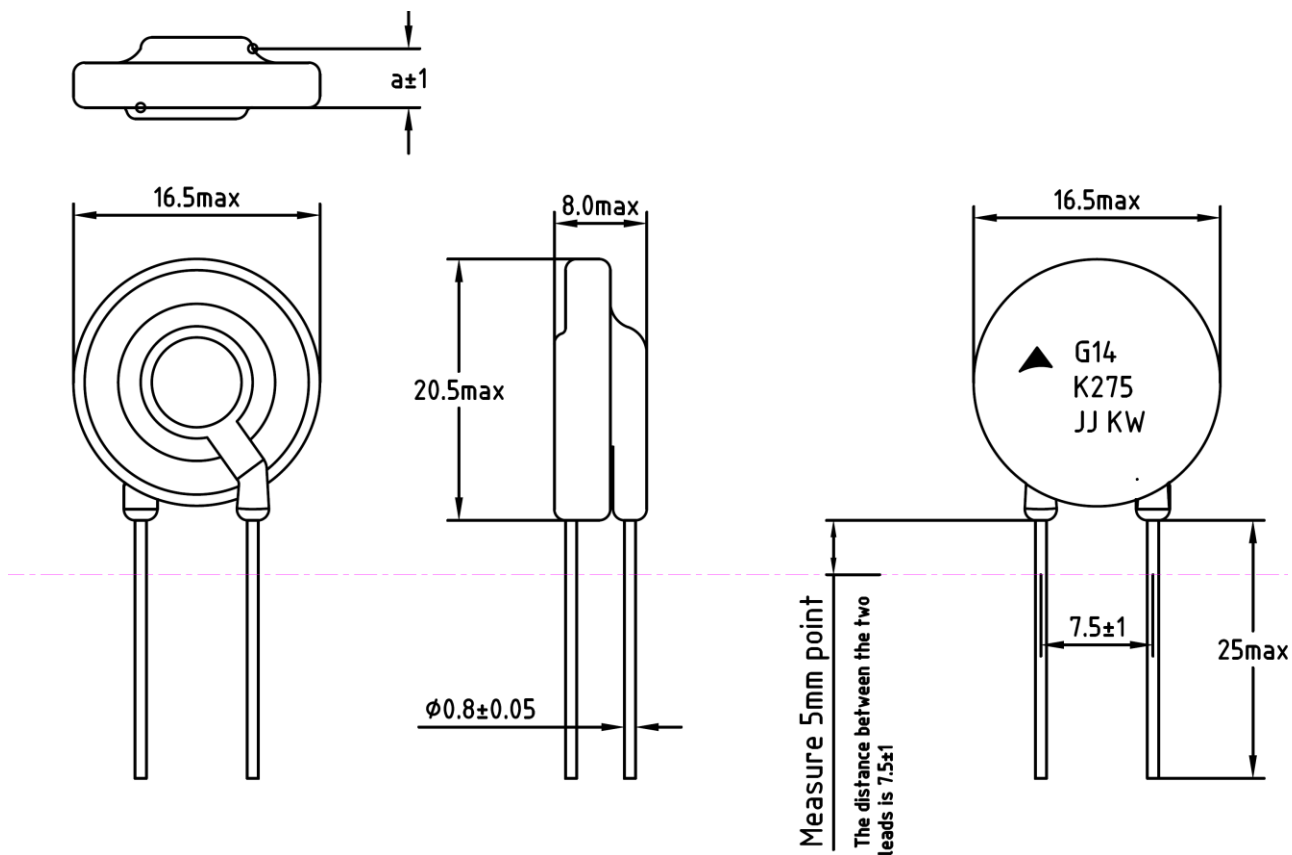

Type	Ordering code	a (mm) ± 1
G14K150	Z62000Z2310Z 11	4.0
G14K275	Z62000Z2310Z 12	4.4
G14K275	Z62000Z2310Z 13	4.6
G14K320	Z62000Z2310Z 14	4.9

G20 series:

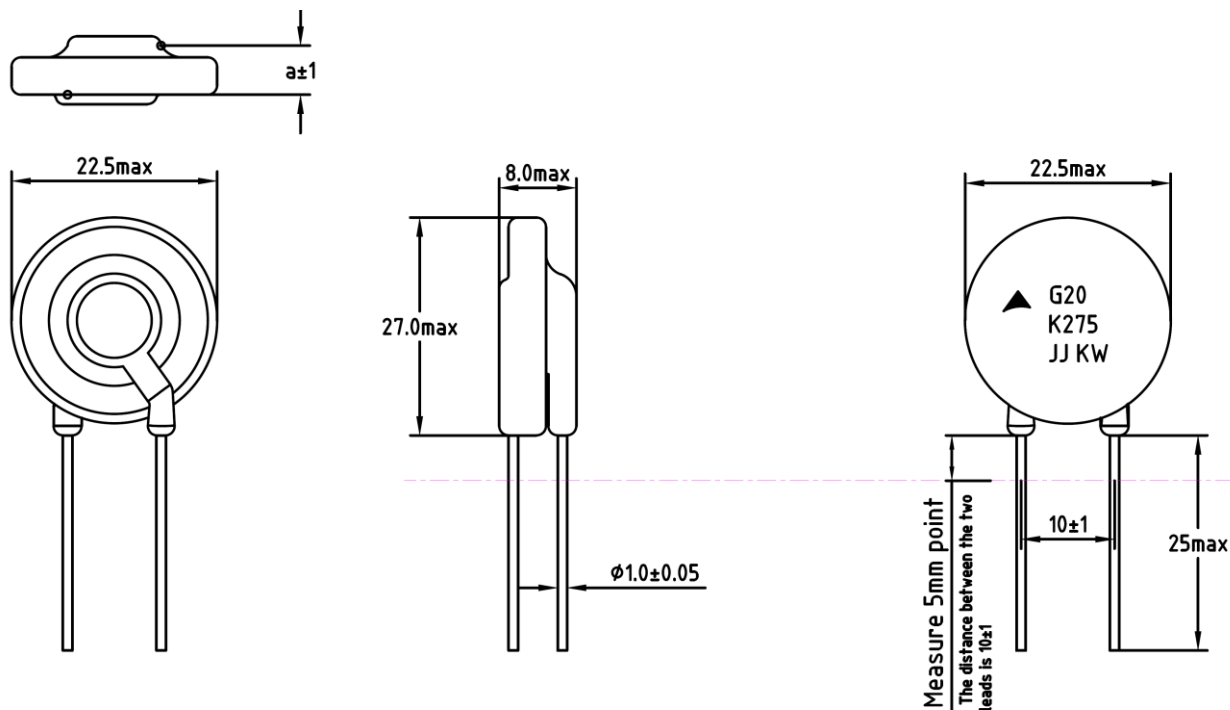

Type	Ordering code	a (mm) ± 1
G20K150	Z62000Z2310Z 15	4.2
G20K230	Z62000Z2310Z 16	4.6
G20K275	Z62000Z2310Z 17	4.8
G20K320	Z62000Z2310Z 18	5.1

Electrical specifications
Characteristics (25 °C)

Type	DC spark-over voltage	Max. operating voltage		I_n	I_{max}	Max. Leakage	Max. Clamping Voltage		W_{max}	P_{max}	
		V_{RMS}	V_{DC}								
SIOV	V	V	V	8/20 $\mu s^*)$	8/20 $\mu s^*)$	At V_{DC}	Vc	A	2 ms	J	W
G14K150	480-720	150	200	3	6	0.1	580	1000	70	0.6	
G14K230	800-1200	230	300	3	6	0.1	900	1000	105	0.6	
G14K275	800-1200	275	350	3	6	0.1	1050	1000	130	0.6	
G14K320	800-1200	320	415	3	6	0.1	1300	1000	150	0.6	

Type	DC spark-over voltage for GDT	Max. operating voltage		I_n	I_{max}	Max. Leakage	Max. Clamping Voltage		W_{max}	P_{max}	
		V_{RMS}	V_{DC}								
SIOV	V	V	V	8/20 $\mu s^*)$	8/20 $\mu s^*)$	At V_{DC}	Vc	A	2 ms	J	W
G20K150	480-720	150	200	5	10	0.1	530	1000	120	1	
G20K230	800-1200	230	300	5	10	0.1	820	1000	180	1	
G20K275	800-1200	275	350	5	10	0.1	950	1000	260	1	
G20K320	800-1200	320	415	5	10	0.1	1150	1000	320	1	

^{*)} Surge test acc. IEC61643-11

Remark:

Above sample is not mass product. These samples can only be used for testing.

Cautions and warnings

General

1. TDK Electronics metal oxide varistors are designed for specific applications and should not be used for purposes not identified in our specifications, application notes and data books unless otherwise agreed with TDK Electronics during the design-in-phase.
2. Ensure suitability of SIOVs through reliability testing during the design-in phase. SIOVs should be evaluated taking into consideration worst-case conditions.
3. For applications of SIOVs in line-to ground circuits based on various international and local standards there are restrictions existing or additional safety measures required.

Storage

After shipment from TDK Electronics the SIOV type series should be soldered within the following time period:

SIOV-S,-Q,L(S),-SNF,-ICL,-B,-E,-G	24 months
SIOV-ETFV,-T,-SMD,-MT-EM,-NT	12 months

The parts are to be left in the original packing to prevent oxidized terminals which can cause soldering problems.

Storage temperature:	-25 to 45°C
Max. relative humidity(without condensation):	<75% annual average, <95% on max. 30 days per annum.

Handling

1. SIOVs must not be dropped.
2. Components must not be touched with bare hands. Gloves are recommended.
3. Avoid contamination of the surface of SIOV electrodes during handling, be careful of the sharp edge of SIOV electrodes.

Soldering (where applicable)

1. Use rosin-type flux or non-activated flux.
2. Insufficient preheating may cause ceramic cracks.
3. Rapid cooling by dipping in solvent is not recommended.
4. Complete removal of flux is recommended.

5. Temperature of all preheat stages and the solder bath must be strictly controlled especially for T series(T14 and T20)

Mounting

1. Potting, sealing or adhesive compounds can produce chemical reactions in the SIOV ceramic that will degrade the component's electrical characteristics.
2. Overloading SIOVs may result in ruptured packages and expulsion of hot materials. For this reason SIOVs should be physically shielded from adjacent components.

Operation

1. Use SIOVs only within the specified temperature operating range
2. Use SIOVs only within the specified voltage and current ranges.
3. Environmental conditions must not harm the SIOVs. Use SIOVs only in normal atmospheric conditions. Avoid use in deoxidizing gases (chlorine gas, hydrogen sulfide gas, ammonia gas, sulfuric acid gas, etc), corrosive agents, humid or salty conditions. Contact with any liquids and solvents should be prevented.

Display of ordering codes for TDK Electronics products

The ordering code for one and the same product can be represented differently in data sheets, data books, other publications, on the company website, or in order-related documents such as shipping notes, order confirmations and product labels. **The varying representations of the ordering codes are due to different processes employed and do not affect the specifications of the respective products.** Detailed information can be found on the Internet under www.tdk-electronics.tdk.com/orderingcodes.

Important notes

The following applies to all products named in this publication:

1. Some parts of this publication contain **statements about the suitability of our products for certain areas of application**. These statements are based on our knowledge of typical requirements that are often placed on our products in the areas of application concerned. We nevertheless expressly point out **that such statements cannot be regarded as binding statements about the suitability of our products for a particular customer application**. As a rule we are either unfamiliar with individual customer applications or less familiar with them than the customers themselves. For these reasons, it is always ultimately incumbent on the customer to check and decide whether a product with the properties described in the product specification is suitable for use in a particular customer application.
2. We also point out that **in individual cases, a malfunction of electronic components or failure before the end of their usual service life cannot be completely ruled out in the current state of the art, even if they are operated as specified**. In customer applications requiring a very high level of operational safety and especially in customer applications in which the malfunction or failure of an electronic component could endanger human life or health (e.g. in accident prevention or life-saving systems), it must therefore be ensured by means of suitable design of the customer application or other action taken by the customer (e.g. installation of protective circuitry or redundancy) that no injury or damage is sustained by third parties in the event of malfunction or failure of an electronic component.
3. **The warnings, cautions and product-specific notes must be observed.**
4. In order to satisfy certain technical requirements, **some of the products described in this publication may contain substances subject to restrictions in certain jurisdictions (e.g. because they are classed as hazardous)**. Useful information on this will be found in our Material Data Sheets on the Internet (www.tdk-electronics.tdk.com/material). Should you have any more detailed questions, please contact our sales offices.
5. We constantly strive to improve our products. Consequently, **the products described in this publication may change from time to time**. The same is true of the corresponding product specifications. Please check therefore to what extent product descriptions and specifications contained in this publication are still applicable before or when you place an order.

We also **reserve the right to discontinue production and delivery of products**. Consequently, we cannot guarantee that all products named in this publication will always be available. The aforementioned does not apply in the case of individual agreements deviating from the foregoing for customer-specific products.

6. Unless otherwise agreed in individual contracts, **all orders are subject to our General Terms and Conditions of Supply**.
7. **Our manufacturing sites serving the automotive business apply the IATF 16949 standard**. The IATF certifications confirm our compliance with requirements regarding the quality management system in the automotive industry. Referring to customer requirements and customer specific requirements ("CSR") TDK always has and will continue to have the policy of respecting individual agreements. Even if IATF 16949 may appear to support the acceptance of unilateral requirements, we hereby like to emphasize that **only requirements mutually agreed upon can and will be implemented in our Quality Management System**. For clarification purposes we like to point out that obligations from IATF 16949 shall only become legally binding if individually agreed upon.

Important notes

8. The trade names EPCOS, CarXield, CeraCharge, CeraDiode, CeraLink, CeraPad, CeraPlas, CSMP, CTVS, DeltaCap, DigiSiMic, ExoCore, FilterCap, FormFit, LeaXield, MiniBlue, MiniCell, MKD, MKK, ModCap, MotorCap, PCC, PhaseCap, PhaseCube, PhaseMod, PhiCap, PowerHap, PQSine, PQvar, SIFERRIT, SIFI, SIKOREL, SilverCap, SIMDAD, SiMic, SIMID, SineFormer, SIOV, ThermoFuse, WindCap, XieldCap are **trademarks registered or pending** in Europe and in other countries. Further information will be found on the Internet at www.tdk-electronics.tdk.com/trademarks.

Release 2020-06