

THIS DRAWING CONTAINS INFORMATION PROPRIETARY TO RF INDUSTRIES,
 ANY UNAUTHORIZED USE OF THIS DRAWING IS EXPRESSLY PROHIBITED
 WITHOUT WRITTEN PERMISSION FROM RF INDUSTRIES.
 ANY VIOLATION IS PUNISHABLE UNDER U.S. COPYRIGHT LAWS.

ALL DIMENSIONS ARE REFERENCE ONLY

PART NO.

RFT-1216-1

REV	DESCRIPTION	DWN	DATE	APPROVED
-	ENGINEERING RELEASE	CZS	10/09/00	JDMc

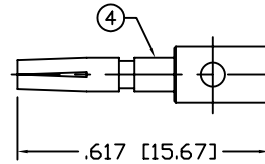
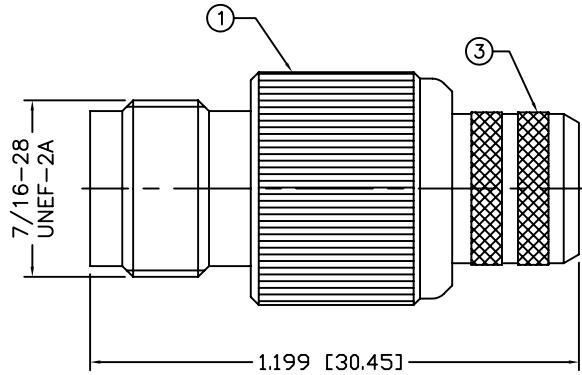

RECOMMENDED CRIMP DIE: .118"
 "SOLDER ONLY" when using RG-8/U TYPE CABLE

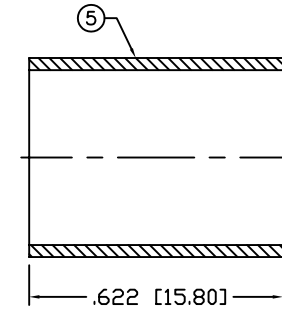

RECOMMENDED CRIMP DIE: .429"

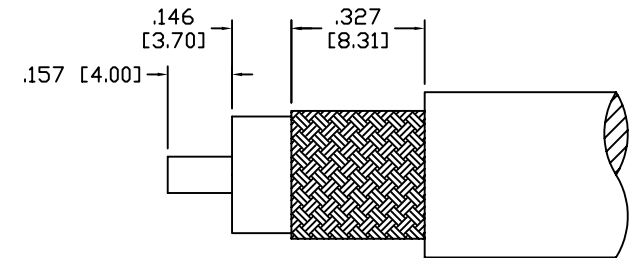

RECOMMENDED STRIPPING DIMENSIONS

SPECIFICATIONS:

IMPEDANCE: 50 Ohms
 FREQUENCY RANGE: 0-7 GHz
 WORKING VOLTAGE: 500 V rms @ sea level
 INSULATION RESISTANCE: 5k M ohms min.
 TEMPERATURE RANGE: -65°C TO +165°C
 FOR BELDEN 8214, 9913, 9913F, 9914, RG-8/U TYPE,
 CAROL C1180, TIMES AA-5886 & LMR-400 CABLE

1	BODY	1	BRASS	NICKEL, 100μ"	008974	
2	INSULATOR	1	PTFE	---		
3	FERRULE STUD	1	BRASS	NICKEL, 100μ"		
4	CONTACT	1	PHOS. BRONZE	GOLD, 3μ"		
5	FERRULE	1	COPPER	NICKEL, 100μ"		
6						
7						
8						
9						
10					DRAWN	
11					C. ZUNIGA	
12					CHECKED	
13						
14					ORJ DRAWN	
					C. ZUNIGA	
#	DESCRIPTION	QTY	MATERIAL	FINISH	APPROVALS	DATE

**RoHS
 COMPLIANT**

DIMENSIONS ARE IN INCHES
 AND [MILLIMETERS]
 UNLESS OTHERWISE NOTED
 TOLERANCES ARE:

DECIMALS DIAMETER

RFconnectors
 DIVISION OF RF INDUSTRIES, LTD.

7610 MIRAMAR RD
 SAN DIEGO, CA 92126
 (858) 549-6340
 (858) 549-6345 FAX

TNC JACK, CRIMP

SIZE	CABLE GROUP	DWG NO.	REV
A	I	RFT-1216-1	-
SCALE:	NTS	CAD FILE	OUTLINE
			SHEET 1 OF 1