

NOTES:

1. MATERIALS AND FINISHES:  
 BODY AND BAYONET SLEEVE - BRASS, NICKEL PLATING  
 OUTER CONTACT - BeCu, NICKEL PLATING  
 CONTACT - PHOSPHOR BRONZE, GOLD PLATING  
 FERRULE - COPPER, NICKEL PLATING  
 INSULATOR - PTFE
2. ELECTRICAL:  
 A. IMPEDANCE: 75 OHM  
 B. FREQUENCY RANGE: DC - 3 GHz  
 C. RETURN LOSS: 30 dB MIN @ DC - 3 GHz  
 D. DIELECTRIC WITHSTANDING VOLTAGE: 1000 VRMS, MIN.  
 E. INSULATION RESISTANCE: 10,000 MΩ MIN
3. MECHANICAL:  
 A. DURABILITY: 500 CYCLES MIN.  
 B. TEMPERATURE RANGE: -65° C TO +165° C
4. ENVIRONMENTAL:  
 A. THERMAL SHOCK PER MIL-STD-202 METHOD 107  
 TEST CONDITION B (EXCEPT HIGH TEMP @200°C)  
 B. VIBRATION: MIL-STD-202 METHOD 204 TEST CONDITION B  
 C. SHOCK: MIL-STD-202 METHOD 213 TEST CONDITION B  
 D. CORROSION: MIL-STD-202 METHOD 101  
 TEST CONDITION B 5% SALT SOLUTION
5. PACKAGING:  
 A. QUANTITY: SINGLE PACK  
 B. MARKING: MARK BAG OR TAG:  
 "AMPHENOL RF, 34-1042 DATE CODE  
 U.S. PATENT NO. 7,553,177"
6. HIGH DENSITY INSTALLATION/REMOVAL TOOL: 227-T2000
7. CABLE ASSEMBLY INSTRUCTIONS:  
 A. TRIM CABLE AS SHOWN.  
 B. SOLDER CONTACT TO CABLE CENTER CONDUCTOR  
 C. INSERT CABLE  
 D. CRIMP FERRULE WITH .128" HEX.

8 SHOWS CABLE ENTRY DIMENSIONS.

INTERFACE PER  
 349-50820  
 SERIES: HD-BNC PLUG

THIRD ANGLE PROJ.

REVISIONS				
REV	DESCRIPTION	DATE	ECO	APPR
A	RELEASE TO MFG.	23-Jan-12	49135	ARUN
B	COUPLING MECHANISM UPDATED	01-Aug-13	49669	KR
C	NOTE 4 IN SHEET 1 WAS CHANGED.	07-Aug-18	08804	SH

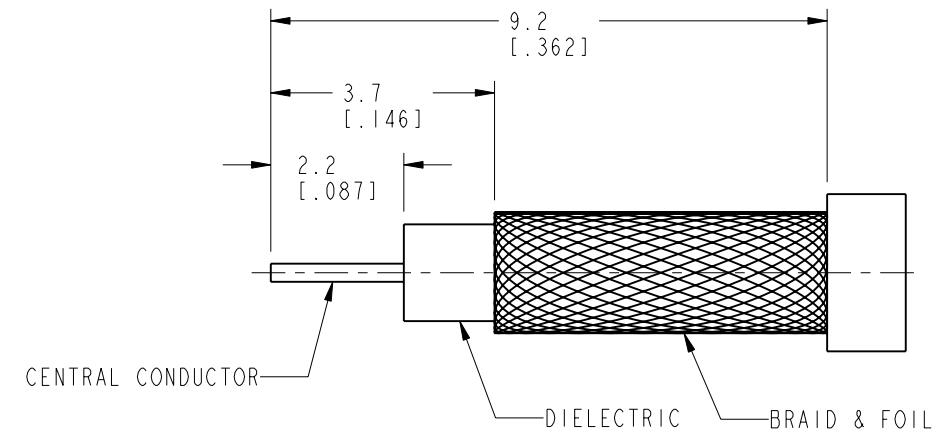

**RECOMMENDED CABLE STRIPPING DIMENSIONS**

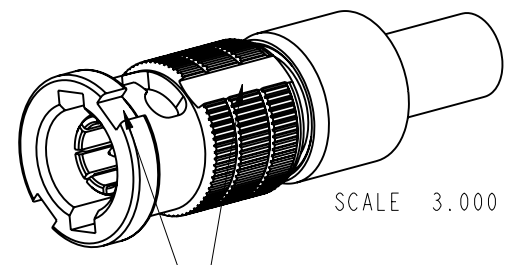

STUD LOCATING AND INSTALLATION/REMOVAL TOOL GROOVES

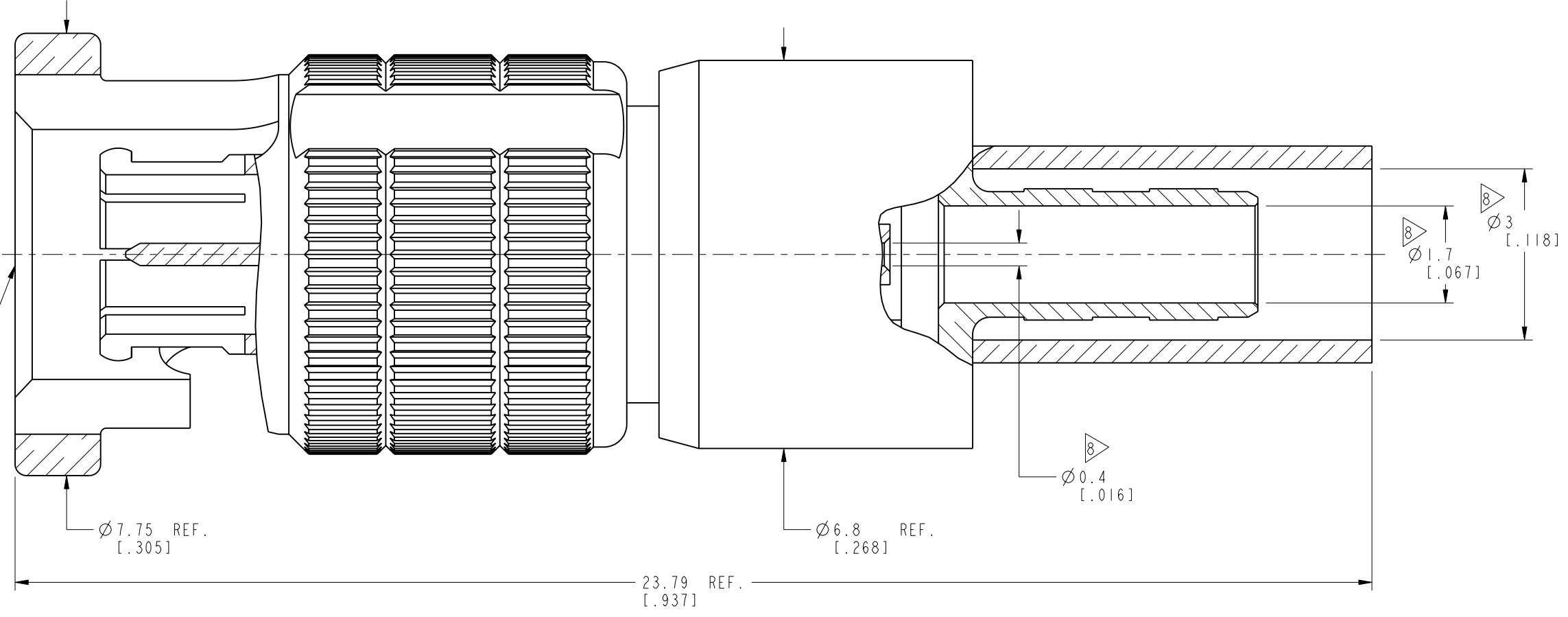

**PROTECTED UNDER U.S. PATENT # 7,553,177**

**CUSTOMER OUTLINE DRAWING**  
 ALL OTHER SHEETS ARE FOR INTERNAL USE ONLY

UNLESS OTHERWISE SPECIFIED, DIMENSIONS ARE IN METRIC AND TOLERANCES ARE: <0.5mm ± 0.05mm    0.5 - 6mm ± 0.1mm    6 - 30mm ± 0.2mm    30 - 120mm ± 0.3mm    ANGLES ± 1°	MATERIAL	DRAWN	DATE	TITLE HD-BNC STR PLUG FOR BELDEN 179DT/ RG 179 CABLE	Amphenol RF www.amphenolrf.com
	SEE NOTES	W. ZENG	9-Aug-18		
NOTICE - These drawings, specifications, or other data (1) are, and remain the property of Amphenol corp. (2) must be returned upon request; and (3) are confidential and not to be disclosed to any person other than those to whom they are given by Amphenol Corp. the furnishing of these drawings, specifications, or other data by Amphenol Corp., or to any other person to anyone for any purpose is not to be regarded by implication or otherwise in any manner licensing, granting rights to permitting such holder or any other person to manufacture, use or sell any product, process or design, patented or otherwise, that may in any way be related to or disclosed by said drawings, specifications, or other data.	REFERENCE	ENGINEER	DATE	SCALE: 11.0:1.0	DRAWING NO. 34-1042
	EAR # 4690	A. ARUN PRABU	23-Jan-12	SHEET 2 OF 2	
	CONFIGURATION LEVEL: In Work	APPROVED	DATE	DWG SIZE	REV
FINISH	S. HSIEH	10-Aug-18	B	C	