

THIS DRAWING IS UNPUBLISHED. RELEASED FOR PUBLICATION
 © COPYRIGHT - By - ALL RIGHTS RESERVED.

REVISIONS				
P	LTR	DESCRIPTION	DATE	APVD
N		REV PER ECO-16-004720	08APR16	KG DW

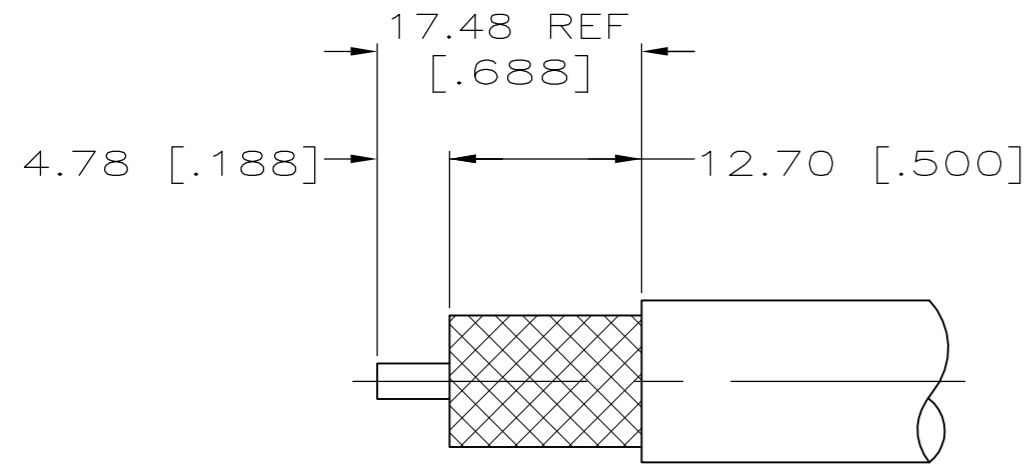

VIEW X
RECOMMENDED STRIP LENGTH

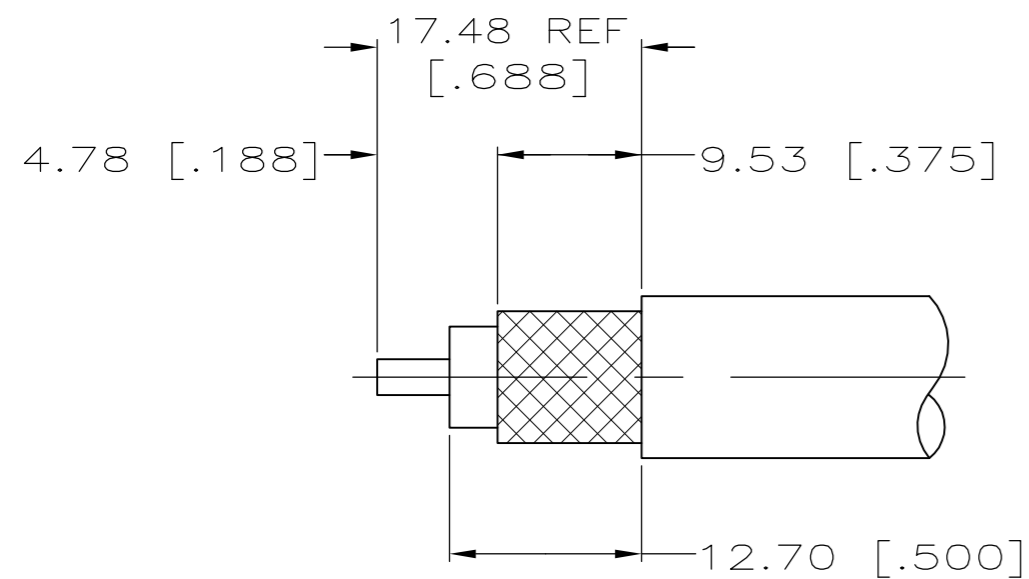

VIEW Y
RECOMMENDED STRIP LENGTH

- 1. PARTS PACKAGED UNASSEMBLED.
- 2. THREE SAFETY WIRE HOLES Ø0.61 [.024] MINIMUM, EQUALLY SPACED AROUND CIRCUMFERENCE.
- 3. SEE INSTRUCTION SHEET #2028-5.
- 4. OBSOLETE PART NUMBER.
- 5. SUPERSEDED BY 225389-4.

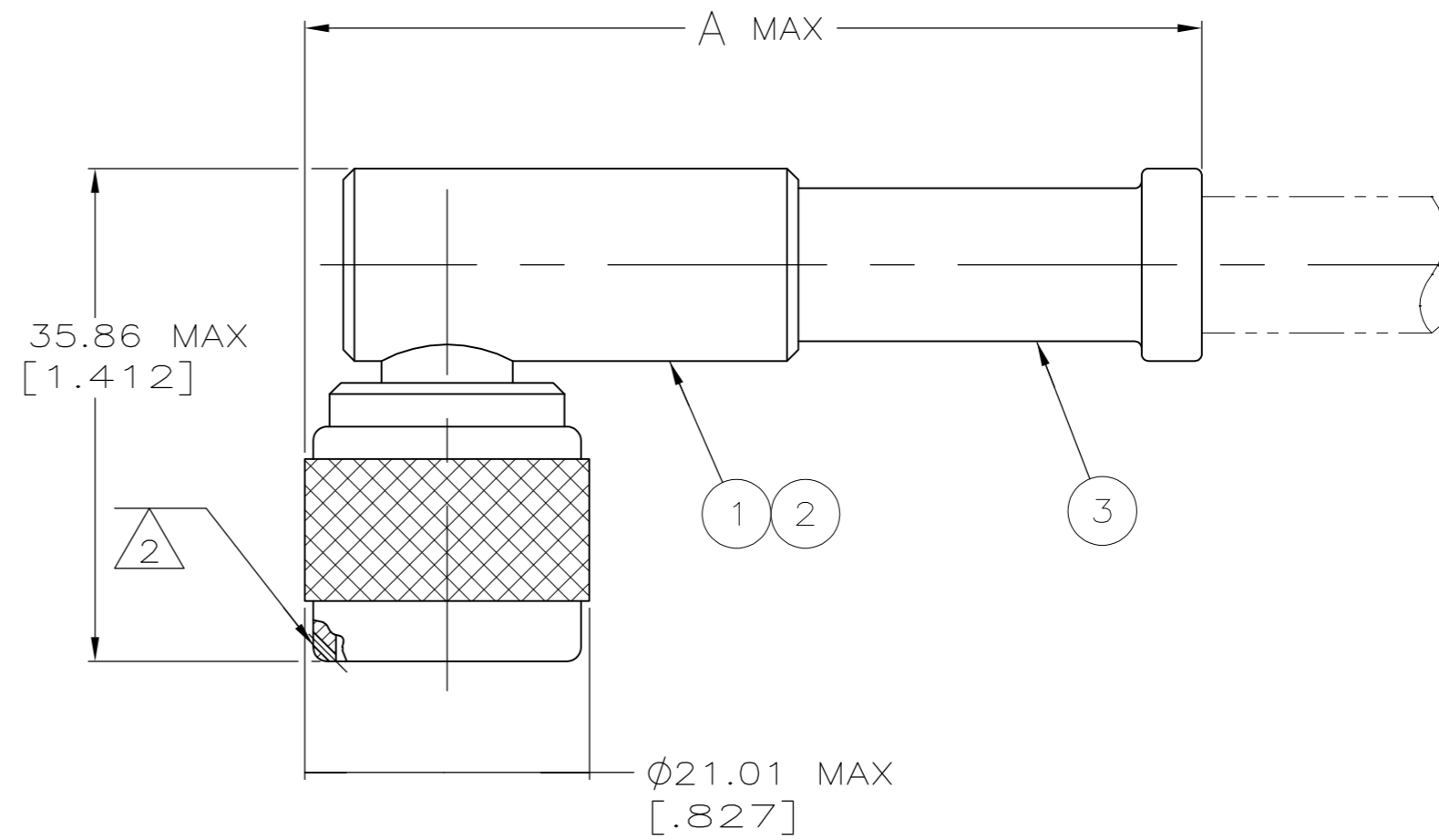

-	-	-	-	-	-	-	-	5 7-225389-4
RG-213/U	7-225389-2 AMP	220015-1	62.31 [2.453]	Y	1-331987-3	51704-2	225417-1	7-225389-2
RG-225/U	5-225389-3 TYCO	220015-1	62.31 [2.453]	X	1883158-1	1-51704-0	1883152-1	5-225389-3
-	-	-	-	-	-	-	-	4 1-225389-0
MICRODOT 250-4172 & 250-4208	225389-9 AMP	220015-3	61.49 [2.421]	Y	9-225612-0	51704-2	225904-1	225389-9
RG-165/U & M15224	225389-8 AMP	220015-1	62.31 [2.453]	Y	9-331987-4	1-51704-0	225417-1	225389-8
RG-393/U	225389-6 AMP	220015-1	62.31 [2.453]	X	9-225490-1	1-51704-0	225417-1	225389-6
RG-214/U	10688467 AMP	220015-1	62.31 [2.453]	X	331987	51704-2	225417-1	4 225389-5
RG-214/U	00779 M39012/05B0003 AMP & DATE CODE	220015-1	62.31 [2.453]	X	331987	51704-2	225417-1	4 225389-4
RG-225/U	225389-3 AMP	220015-1	62.31 [2.453]	X	9-331987-3	1-51704-0	225417-1	225389-3
RG-213/U	00779 M39012/05B0002 AMP & DATE CODE	220015-1	62.31 [2.453]	Y	9-331987-4	51704-2	225417-1	225389-2
RG-115A/U	225389-1 AMP	220015-1	62.31 [2.453]	X	1-331987-3	51704-2	225417-2	4 225389-1
CABLE SIZE	STAMPING	CRIMP TOOL	A	VIEW	3 FERRULE QTY=1	2 CONTACT QTY=1	1 PLUG ASSY QTY=1	PART NUMBER

THIS DRAWING IS A CONTROLLED DOCUMENT.

DWN	B. SCOTT	5-29-91
CHK	M. SNEED	10-30-91
APVD	M. SNEED	10-31-91
PRODUCT SPEC	108-12019	
APPLICATION SPEC		
WEIGHT	0.000000	
CUSTOMER DRAWING		

TE TE Connectivity

PLUG, RIGHT ANGLE, WEATHERPROOF, SERIES N

SIZE	A2	CAGE CODE	00779	DRAWING NO	C=225389	RESTRICTED TO	-
SCALE	2:1	SHEET	1 of 1	REV	N		