

# RIGHTANGLE PLUG M12 FEMALE

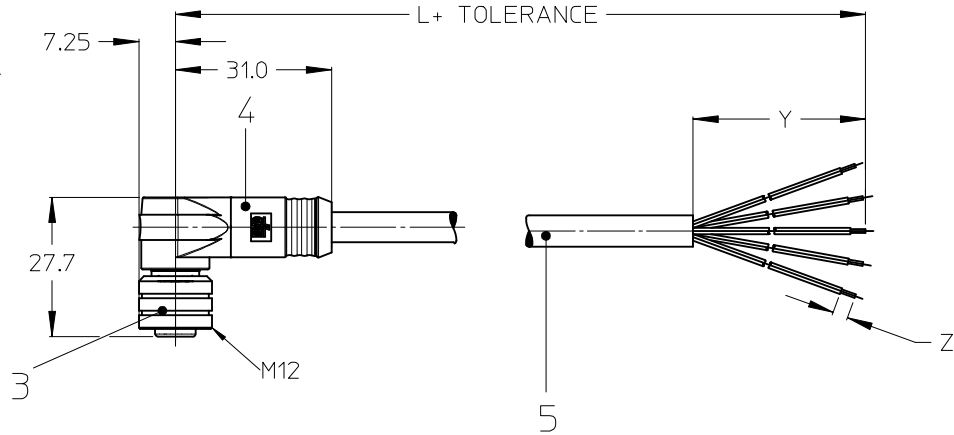
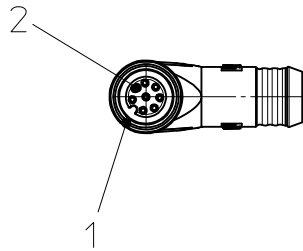

### NOTES:

TEMPERATURE RANGE	SEE TABLE ON PAGE 2
CONTACT CURRENT RATING	3-5 POLES 4A 8 POLES 2A
VOLTAGE RATING	3-4 POLES 250V 5 POLES 60V 8 POLES 30V
PROTECTION CLASS	IP 67

### TOLERANCES

≤ 1m	+20/-10mm
1m - 5m	± 25mm
5m - 10m	± 30mm
> 10m	± 30mm
> 20m	± 50mm

	3 POL	4 POL	5 POL	8 POL	REMARKS
Y	30 +/-2	50 +/-2	50 +/-2	80 +/-3	OPEN END FOR TESTING
Z	3-6	3-6	3-6	3-6	NOT DEFINED

3 WIRE	4 WIRE	5 WIRE	8 WIRE
PIN # WIRE	PIN # WIRE	PIN # WIRE	PIN # WIRE
1 BROWN 2 - 3 BLUE 4 BLACK 5 -	1 BROWN 2 WHITE 3 BLUE 4 BLACK 5 -	1 BROWN 2 WHITE 3 BLUE 4 BLACK 5 GREY	1 WHITE 2 BROWN 3 GREEN 4 YELLOW 5 GREY 6 PINK 7 BLUE 8 RED
REQUIRED TO IEC 60947-5-2		REQUIRED TO DIN 47100	

ITEM	PART	MATERIAL	FINISH
5	CABLE	SEE TABLE (PAGE 2)	---
4	OVERMOULDING	TPU	SEE CODE (PAGE 2)
3	MALE COUPLING NUT	BRASS	SEE CODE (PAGE 2)
2	PIN CONTACT	BRASS	GOLD PLATED
1	INSERT	PUR	BLACK

<b>ENTER DESCRIPTION</b> EC NO: IPG2014-0078 DRWN: PMERUNKA 2012/04/24 CHKD: JELIZAINCIN 2013/07/10 APPR: CBURGER 2013/07/16	<b>QUALITY SYMBOLS</b> ▽=0 ◻=0	<b>GENERAL TOLERANCES (UNLESS SPECIFIED)</b>		<b>DIMENSION STYLE</b> MM ONLY		SCALE 1:1	DESIGN UNITS METRIC	THIRD ANGLE PROJECTION	
		mm      INCH		DRAWN BY PMERUNKA	DATE 2012/04/24	TITLE CSE M12 XP AC FE RA XM SE UNSH			
		4 PLACES ± --- ± --- 3 PLACES ± --- ± --- 2 PLACES ± 0.05 ± --- 1 PLACE ± 0.10 ± --- 0 PLACE ± --- ± ---		CHECKED BY RSILLER	DATE 2013/01/18	APPROVED BY CBURGER			
		ANGULAR ± .5 °		MATERIAL NO. SEE TABLE		DOCUMENT NO. SD-120065-052		SHEET NO. 1 OF 4	
DRAFT WHERE APPLICABLE MUST REMAIN WITHIN DIMENSIONS		THIS DRAWING CONTAINS INFORMATION THAT IS PROPRIETARY TO MOLEX INCORPORATED AND SHOULD NOT BE USED WITHOUT WRITTEN PERMISSION							

**NUMERICAL CODE** (Available parts see table page 3 ff others on request.)

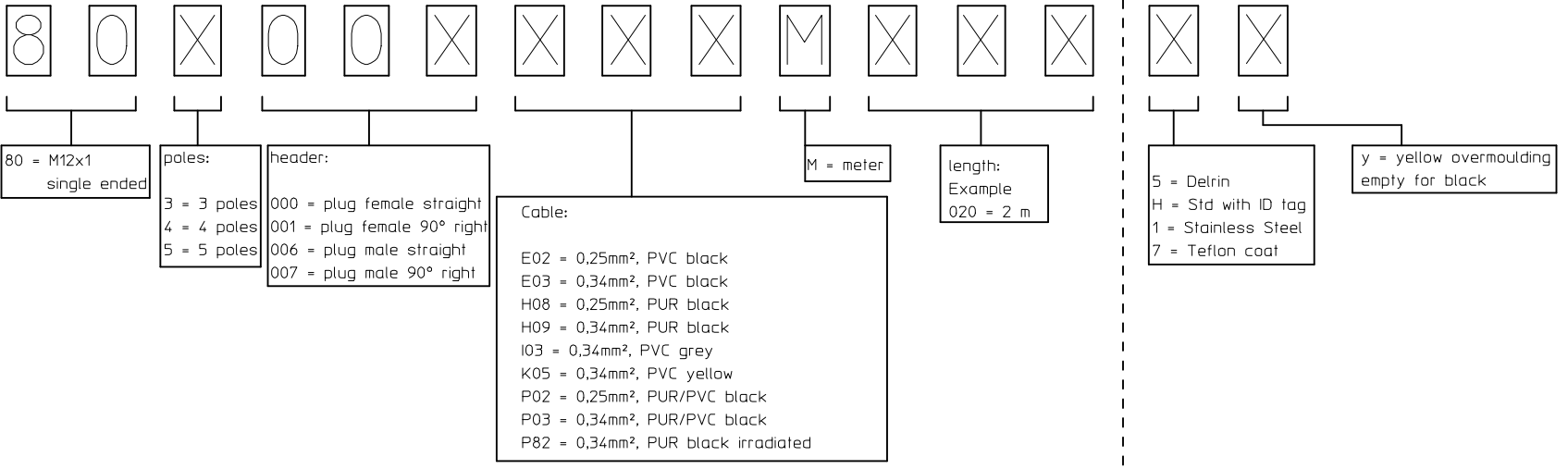

CABLE TYPE	WIRE GAUGE	CABLE JACKET	UL	CSA	static	flexing	drag chain tested	other
E02	0.25mm <sup>2</sup>	PVC black	STYLE 2464	I/II A/B 80°/300V	-30°C to +80°C 5xD	-5°C to +80°C 9xD	---	---
E03	0.34mm <sup>2</sup>	PVC black	STYLE 2464	I/II A/B 80°/300V	-30°C to +80°C 5xD	-5°C to +80°C 9xD	---	---
H08	0.25mm <sup>2</sup>	PUR black	AWM STYLE 21198/10493	APPROVED	-50°C to +80°C 5xD	-25°C to +80°C 10xD	200000 cycles	---
H09	0.34mm <sup>2</sup>	PUR black	AWM STYLE 21198/10493	APPROVED	-50°C to +80°C 5xD	-25°C to +80°C 10xD	drag chain 60°C	---
I03	0.34mm <sup>2</sup>	PVC grey	---	---	-30°C to +70°C	-5°C to +70°C	---	---
K05	0.34mm <sup>2</sup>	PVC yellow	ITC E195601 or PLTC	AWM I/II A/B FT4 LL54185	---	---	---	CSA-US:ITC LL54185-02
P02	0.25mm <sup>2</sup>	PUR/PVC black	not applicable	not applicable	-30°C to +80°C 7xD	-5°C to +80°C 15xD	---	---
P03	0.34mm <sup>2</sup>	PUR/PVC black	not applicable	not applicable	-30°C to +80°C 7xD	-5°C to +80°C 15xD	---	---
P82	0.34mm <sup>2</sup>	irrad. PUR orange	---	---	-50°C to +105°C 5xD	-40°C to +105°C 7.5xD	---	---

ENTER DESCRIPTION EC NO: IPG2014-0078 DRWN: PMERUNKA 2012/04/24 CHKD: JEL IZAINCIN 2013/07/10 APPR: CBURGER 2013/07/16	QUALITY SYMBOLS ▽=0 ◻=0	GENERAL TOLERANCES (UNLESS SPECIFIED)		DIMENSION STYLE <b>MM ONLY</b>		SCALE <b>1:1</b>	DESIGN UNITS <b>METRIC</b>	THIRD ANGLE PROJECTION			
		4 PLACES ± --- ± ---	3 PLACES ± --- ± ---	2 PLACES ± 0.05 ± ---	1 PLACE ± 0.10 ± ---	0 PLACE ± --- ± ---	DRAWN BY PMERUNKA	DATE 2012/04/24	TITLE <b>CSE M12 XP AC FE RA XM SE UNSH</b>		
		ANGULAR ± .5 °					CHECKED BY RSILLER	DATE 2013/01/18			
		DRAFT WHERE APPLICABLE MUST REMAIN WITHIN DIMENSIONS					APPROVED BY CBURGER	DATE 2013/07/16	<b>molex</b> DOCUMENT NO. SD-120065-052 SHEET NO. 2 OF 4		
					MATERIAL NO. SEE TABLE						

P/N	Engineering-No
1200062292	803001E03M003
1200658046	803001E03M006
1200658047	803001E03M0061
1200062402	803001E03M008
1200060175	803001E03M010
1200061542	803001E03M011
1200060007	803001E03M020
1200061541	803001E03M022
1200060178	803001E03M030
1200061540	803001E03M033
1200658564	803001E03M040
1200658048	803001E03M0401
1200060008	803001E03M050
1200658234	803001E03M0501
1200658268	803001E03M0505
1200658886	803001E03M050H
1200061538	803001E03M051
1200061553	803001E03M058
1200061552	803001E03M066
1200060009	803001E03M100
1200658269	803001E03M1005
1200658885	803001E03M100H
1200060184	803001E03M150
1200060187	803001E03M200
1200658713	803001H09M010
1200658714	803001H09M015
1200658715	803001H09M020
1200658716	803001H09M030
1200658717	803001H09M040
1200658718	803001H09M050
1200698320	804S01P20M050Y
1200659117	805001I26M100Y
1200659083	805001E03M100Y
1200659084	805001I26M050Y
1200659101	808001H08M050Y
1200659105	808001H08M100Y

P/N	Engineering-No
1200658719	803001H09M100
1200060202	803001I03M020
1200062851	803001I03M025
1200060204	803001I03M030
1200658052	803001I03M036
1200658594	803001I03M040
1200060010	803001I03M050
1200064210	803001I03M051
1200060205	803001I03M100
1200658287	803001I20M100
1200651489	803001K05M020
1200651490	803001K05M040
1200651491	803001K05M050
1200651492	803001K05M060
1200651493	803001K05M100
1200651494	803001K05M120
1200658403	803001P03M003
1200658237	803001P03M006
1200061318	803001P03M010
1200060011	803001P03M020
1200010769	803001P03M020X
1200062027	803001P03M022
1200063340	803001P03M025
1200060212	803001P03M030
1200065013	803001P03M030G
1200658611	803001P03M040
1200060012	803001P03M050
1200658976	803001P03M0505
1200651773	803001P03M050G
1200060013	803001P03M100
1200060216	803001P03M150
1200658311	803001P03M200
1200658312	803001P03M300
1200658547	803001P20M150
1200063682	803001P82M020

P/N	Engineering-No
1200658668	804001H09M010
1200658669	804001H09M015
1200658513	804001H09M020
1200658670	804001H09M030
1200658671	804001H09M040
1200658193	804001H09M050
1200064433	804001H09M050G
1200658010	804001H09M050H
1200658194	804001H09M100
1200064436	804001H09M100G
1200658011	804001H09M100H
1200658195	804001H09M150
1200658185	804001H09M150G
1200658196	804001H09M200
1200658485	804001H69M010
1200062093	804001H69M100
1200061935	804001I03M010
1200658707	804001I03M010G
1200060503	804001I03M020
1200658708	804001I03M020G
1200060505	804001I03M030
1200658709	804001I03M030G
1200064244	804001I03M040
1200658710	804001I03M040G
1200060042	804001I03M050
1200062575	804001I03M0501
1200063532	804001I03M0505
1200658711	804001I03M050G
1200060507	804001I03M100
1200658712	804001I03M100G
1200060508	804001I03M150
1200063563	804001I04M030G
1200062112	804001I20M003
1200658276	804001I20M100
1200062161	804001P82M1007

P/N	Engineering-No
1200062148	804001I20M160
1200651622	804001K03M010
1200651623	804001K03M020
1200650907	804001K03M0208
1200651625	804001K03M030
1200651626	804001K03M040
1200651863	804001K03M0402
1200650908	804001K03M0408
1200651628	804001K03M050
1200651630	804001K03M0502
1200650909	804001K03M0508
1200651631	804001K03M060
1200651632	804001K03M0602
1200651633	804001K03M080
1200651634	804001K03M100
1200651635	804001K03M150
1200652059	804001K03M200
1200651638	804001K05M010
1200651639	804001K05M020
1200651640	804001K05M030
1200651641	804001K05M040
1200651642	804001K05M050
1200651643	804001K05M060
1200651644	804001K05M100
1200652139	804001K05M150
1200651995	804001K05M250
1200063405	804001P03M003
1200010071	804001P03M003W
1200010072	804001P03M006W
1200061986	804001P03M010
1200658624	804001P03M010G
1200010073	804001P03M010W
1200010074	804001P03M015W
1200060024	804001P03M020
1200651783	804001P03M020G

P/N	Engineering-No
1200010075	804001P03M020W
1200010777	804001P03M020X
1200060510	804001P03M030
1200658625	804001P03M030G
1200010076	804001P03M030W
1200652147	804001P03M040
1200658631	804001P03M040G
1200060025	804001P03M050
1200651784	804001P03M050A
1200651785	804001P03M050G
1200651786	804001P03M050GQ
1200658992	804001P03M050H
1200010077	804001P03M050W
1200658206	804001P03M060
1200010078	804001P03M070W
1200651787	804001P03M100
1200064391	804001P03M1001
1200062313	804001P03M100H
1200010079	804001P03M100W
1200064350	804001P03M120
1200063793	804001P03M140
1200060516	804001P03M150
1200010080	804001P03M150W
1200060517	804001P03M200
1200064289	804001P03M400
1200658324	804001P20M030
1200062922	804001P20M050
1200062919	804001P20M100
1200064184	804001P20M250
1200071330	804001P82M0207
1200062155	804001P82M030
1200062520	804001P82M050
1200060043	804001P82M0507
1200062615	804001P82M100

ENTER DESCRIPTION EC NO: IPG2014-0078 DRWN: PMERUNKA 2012/04/24 CHKD: JEL IZAINCIN 2013/07/10 APPR: CBURGER 2013/07/16 REV 1	QUALITY SYMBOLS ▽ = 0 ◻ = 0	GENERAL TOLERANCES (UNLESS SPECIFIED) mm      INCH 4 PLACES ± --- ± --- 3 PLACES ± --- ± --- 2 PLACES ± 0.05 ± --- 1 PLACE ± 0.10 ± --- 0 PLACE ± --- ± --- ANGULAR ± .5 ° DRAFT WHERE APPLICABLE MUST REMAIN WITHIN DIMENSIONS	DIMENSION STYLE MM ONLY DRAWN BY: PMERUNKA      DATE: 2012/04/24 CHECKED BY:              DATE: RSILLER                      2013/01/18 APPROVED BY:              DATE: CBURGER                      2013/07/16	SCALE: 1:1 DESIGN UNITS: METRIC THIRD ANGLE PROJECTION	TITLE: CSE M12 XP AC FE RA XM SE UNSH MATERIAL NO.: SEE TABLE DOCUMENT NO.: SD-120065-052 SHEET NO.: 3 OF 4
	THIS DRAWING CONTAINS INFORMATION THAT IS PROPRIETARY TO MOLEX INCORPORATED AND SHOULD NOT BE USED WITHOUT WRITTEN PERMISSION				
	SIZE: A3				

P/N	Engineering-No
1200658006	804001P82M1507
1200658007	804001P82M2007
1200658573	805001E03M010
1200060652	805001E03M020
1200658574	805001E03M030
1200658575	805001E03M040
1200060654	805001E03M050
1200060655	805001E03M0501
1200060657	805001E03M100
1200658359	805001E03M150
1200658664	805001H09M010
1200658665	805001H09M015
1200658296	805001H09M020
1200658666	805001H09M030
1200658667	805001H09M040
1200658297	805001H09M050
1200658298	805001H09M100
1200658471	805001I03M010
1200658326	805001I03M015
1200658607	805001I03M030
1200658608	805001I03M040
1200061563	805001I03M050
1200063825	805001I03M050G
1200062334	805001I03M100
1200061850	805001I26M050
1200063564	805001I26M100
1200658548	805001I26M250
1200651720	805001K03M020
1200651721	805001K03M040
1200651722	805001K03M050
1200651723	805001K03M060
1200652155	805001K03M100
1200658617	805001P03M010
1200060663	805001P03M020
1200658627	805001P03M030

P/N	Engineering-No
1200658184	805001P03M040
1200651793	805001P03M050
1200658988	805001P03M050H
1200652156	805001P03M060
1200060664	805001P03M100
1200658989	805001P03M100H
1200061760	805001P03M150
1200658314	805001P03M200
1200062872	805001P12M0075
1200658089	805001P12M020
1200658933	805001P12M050
1200658934	805001P12M100
1200063165	805001P20M050
1200064095	805001P20M100
1200655071	805001P82M020
1200063386	805001P82M050
1200062764	805001P82M100
1200658585	808001E02M010
1200658586	808001E02M020
1200658587	808001E02M030
1200658588	808001E02M040
1200658261	808001E02M050
1200658310	808001E02M0501
1200658589	808001E02M100
1200658931	808001E02M150
1200658932	808001E02M250
1200651797	808001E52M020
1200651798	808001E52M050A
1200062838	808001E52M100
1200651799	808001E52M200A
1200658647	808001H08M010
1200658648	808001H08M015
1200658649	808001H08M020
1200658650	808001H08M030
1200658651	808001H08M040

P/N	Engineering-No
1200658245	808001H08M050
1200658652	808001H08M100
1200658683	808001I02M010
1200658684	808001I02M020
1200658685	808001I02M030
1200658686	808001I02M040
1200658687	808001I02M050
1200658688	808001I02M100
1200658619	808001P02M010
1200650960	808001P02M020
1200658620	808001P02M030
1200650961	808001P02M040
1200650962	808001P02M050
1200063754	808001P02M0501A
1200650963	808001P02M100
1200658483	808001P02M150
1200658106	808001P19M030
1200655008	808001P19M050
1200658328	808001P19M100
1200658544	808001P19M250
1200659118	803001I03M050Y
1200659120	803001I03M030Y
1200659121	803001I03M100Y
1200659056	803001E03M050Y
1200659057	803001E03M100Y
1200659074	803001E03M150Y
1200659124	804001H09M100HY
1200659061	804001E03M020Y
1200659062	804001E03M050Y
1200659063	804001E03M100Y
1200659068	804001I03M050Y
1200659069	804001P82M0507Y
1200659077	804001E03M150Y
1200659078	804001I03M100Y
1200659079	804001S20M050Y

P/N	Engineering-No
1200659086	804001P82M1007Y
1200668648	804001P82M0207Y
1200659091	804001S20M100Y
1200659093	804001A09M050Y
1200659094	804001A09M100Y
1200659095	804001H09M050HY
1200659098	804001S20M200Y
1200659099	804001H09M050Y
1200659108	804001P03M050HY

ENTER DESCRIPTION EC NO: IPG2014-0078 DRWN:PMERUNKA 2012/04/24 CHKD:JEL IZAINCIN 2013/07/10 APPR:CBURGER 2013/07/16	DESCRIPTION 1	QUALITY SYMBOLS ▽=0 ◻=0	GENERAL TOLERANCES (UNLESS SPECIFIED) mm    INCH 4 PLACES ± --- ± --- 3 PLACES ± --- ± --- 2 PLACES ± 0.05 ± --- 1 PLACE ± 0.10 ± --- 0 PLACE ± --- ± ---	DIMENSION STYLE MM ONLY DRAWN BY: PMERUNKA    DATE: 2012/04/24 CHECKED BY: RSILLER    DATE: 2013/01/18 APPROVED BY: CBURGER    DATE: 2013/07/16	SCALE: 1:1 DESIGN UNITS: METRIC THIRD ANGLE PROJECTION	TITLE: CSE M12 XP AC FE RA XM SE UNSH   DOCUMENT NO. SD-120065-052 SHEET NO. 4 OF 4
		ANGULAR ± .5 ° DRAFT WHERE APPLICABLE MUST REMAIN WITHIN DIMENSIONS	MATERIAL NO. SEE TABLE			
		SIZE: A3	THIS DRAWING CONTAINS INFORMATION THAT IS PROPRIETARY TO MOLEX INCORPORATED AND SHOULD NOT BE USED WITHOUT WRITTEN PERMISSION			