

PART NUMBER	REV	FIRST USED	POWER UNIT	FEED TYPE	DESCRIPTION
1852537-1	A	122500-1	LEADMAKER	POST FEED	CUTS CARRIER
1852537-2	A	565435-5	BENCH MODEL K	PRE FEED	CUTS CARRIER
1852537-3	A	354500-1	BENCH MODEL G	PRE FEED	CUTS CARRIER
1852537-6	A	122500-1	LEADMAKER	POST FEED	CONTINUOUS CARRIER
7-1852537-7	A	-	-	-	SPARE PARTS

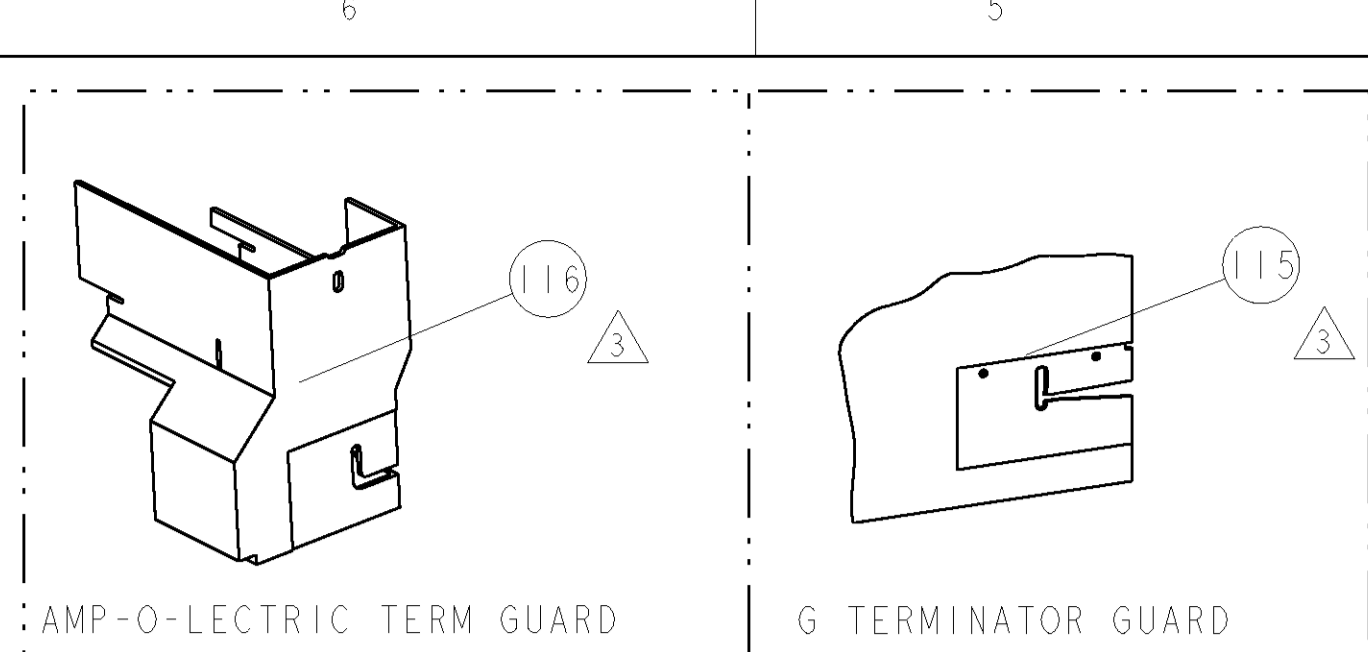

TE PN		MANF PN		MOLEX TERMINAL - TE CRIMP SPECS	
1949467	35747-0210				
1949509	35748-0210	PAD LTR		CRIMP HEIGHT	WIRE SIZE
1949510	35746-0210	A		1.73±0.05mm [.068±.002]	14 AWG
1949441	35745-0210	B		1.52±0.05mm [.060±.002]	16AWG
-	-	C		1.42±0.05mm [.056±.002]	18AWG
-	-	D		±.002 [±0.05mm]	-
CRIMP	SIZE	TYPE	RANGE		
-	-	-	-		
-	-	WIRE	2.29mm [.090]	F	14-18 AWG
-	-	INSUL	3.56mm [.140]	F	3.8mm MAX
WIRE STRIP LENGTH	TERM APPL SPEC	FEED	APPLICATOR INSTRUCTIONS		SET UP GAGE
3.91-4.28mm	NONE	11.99mm	408-8040		458637-1

LOC	DIST	REVISIONS			
A	66	P LTR	DESCRIPTION	DATE	DWN
		A	PRODUCT RELEASE	10APR2008	CMR

- △ RECOMMENDED SPARE PARTS
- △ GREASE LIGHTLY
- △ GUARD MUST BE IN PLACE WHEN OPERATING APPLICATOR IN A BENCH MACHINE

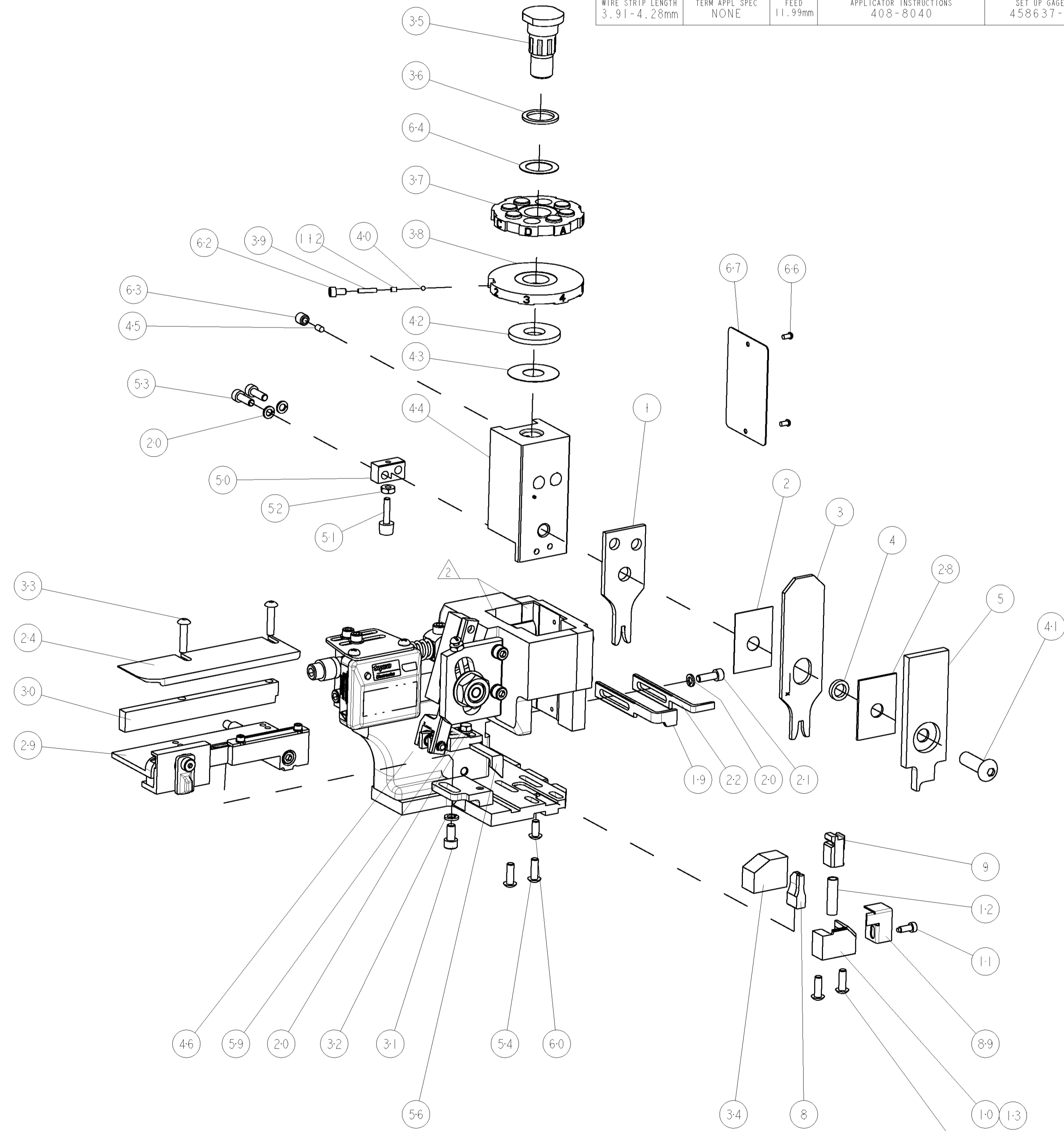
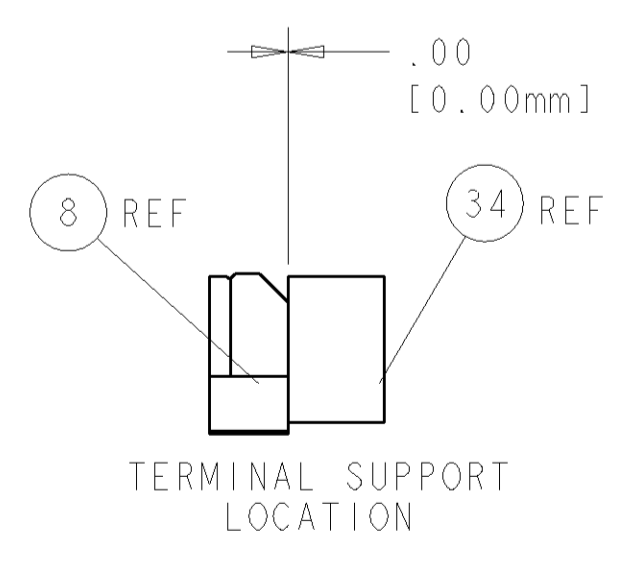
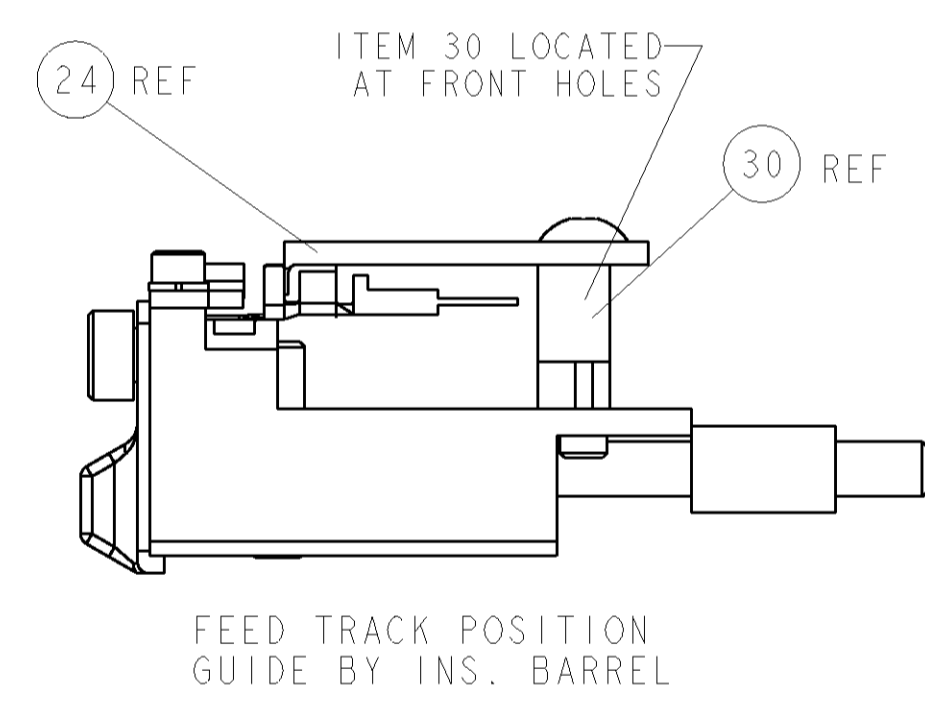
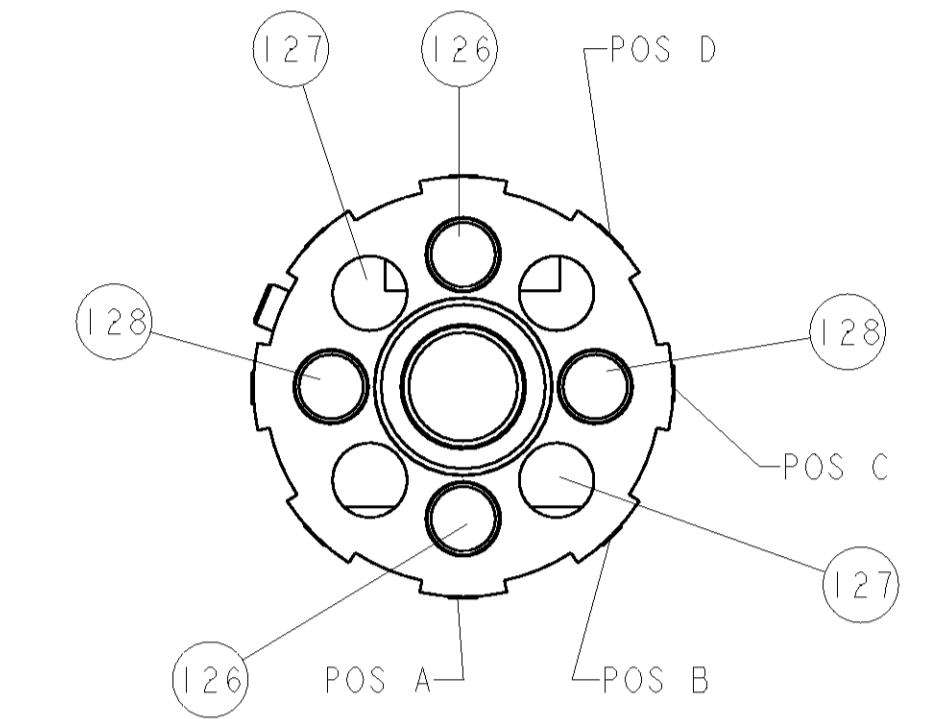

-	2	2	2	2	-	1-354779-4	PIN, WIRE DISC, .3060	128
-	2	2	2	2	-	354779-6	PIN, WIRE DISC, .3020	127
-	2	2	2	2	-	8-354778-8	PIN, WIRE DISC, .2935	126
△	-	-	REF	-	..	455749-1	GUARD WINDOW	116
△	-	-	REF	-	..	679532-1	INSERT, GUARD	115
-	1	1	1	1	-	690603-1	SPRING ASSIST AMP-O-MATOR APPLICATOR	112
-	1	1	1	1	-	1-21002-7	SCR, BTN SKT HD CAP 6-32 X .375	91
-	1	1	1	1	-	318563-1	GUARD, FRONT CHIP	89
-	1	1	1	1	-	4088040	SF APPL INST 408-8040	72
-	1	1	1	1	-	217238-1	GENERAL INSTRUCTION PKG	71
-	1	1	1	1	-	461264-1	PLATE, IDENTIFICATION	67
-	2	2	2	2	-	21017-2	SCREW, DRIVE	66
-	1	1	1	1	-	986950-1	WASHER, FLAT PRECISION	64
-	1	1	1	1	-	21009-2	SCR, SET, SELF LOCKING 1/4-20 X .250	63
-	1	1	1	1	-	23030-1	SCR, SKT HD CAP 6-32 X .25	62
-	1	1	1	1	-	22733-8	SCR, BHSC, SELF-LOCKING, 8-32 X .375	60
-	1	1	1	1	-	2-22603-0	SCR, HEX HD CAP 8-32 X .312	59
-	1	1	1	1	-	458537-2	PAWL, FEED	56
-	4	4	4	4	-	2-21002-2	SCR, BTN SKT HD CAP 8-32 X .500	54
-	2	2	2	2	-	2-21000-7	SCR, SKT HD CAP 8-32 X .500	53
-	1	1	1	1	-	21018-5	NUT, HEX, REG 6-32	52
-	1	1	1	1	-	811242-2	BUMPER, HOLD DOWN	51
-	1	1	1	1	-	690753-1	SPACER, TONKER	50
-	-	-	-	-	..	690602-6	CAM, PRE FEED, 1 5/8	49
-	-	-	-	-	..	690602-5	CAM, PRE FEED, 1 1/8	48
-	1	-	-	-	-	690501-4	CAM, POST FEED, 1 5/8	47
-	1	1	1	1	-	459456-1	APPL. BASIC SUB ASSY (SIDE WISE MOCA)	46
-	1	1	1	1	-	690191-1	PLUG, NYLON	45
-	1	1	1	1	-	455673-1	RAM, SIDE FEED	44
-	1	1	1	1	-	690125-1	SHIM SUB-ASSY	43
-	1	1	1	1	-	690124-1	WASHER, RAM (.115)	42
-	1	1	1	1	-	7-21002-9	SCR, BTN SKT HD CAP 5/16-24 X 1.00	41
-	1	1	1	1	-	23241-6	BALL, STEEL	40
-	1	1	1	1	-	690170-1	SPRING, COMPRESSION	39
-	1	1	1	1	-	690142-1	DISC, INSULATION	38
-	1	1	1	1	-	354777-1	WIRE DISC, ASSEMBLY	37
-	1	1	1	1	-	22480-5	SPRING, COMPRESSION	36
-	1	1	1	1	-	690212-1	POST, RAM	35
-	1	1	1	1	-	690786-3	TERMINAL SUPPORT	34
-	2	2	2	2	-	2-21002-4	SCR, BTN SKT HD CAP 8-32 X .750	33
-	1	1	1	1	-	21024-5	WASHER, SPRG LOCK, REG NO 10	32
-	1	1	1	1	-	3-21000-4	SCR, SKT HD CAP 10-32 X .375	31
-	1	1	1	1	-	1320908-1	SPACER, STRIP GUIDE	30
-	1	1	1	1	-	1633091-1	ASSEMBLY, STRIP GUIDE	29
-	1	1	1	1	-	1-455888-0	SPACER, CRIMPER	28
-	1	1	1	1	-	1320928-1	PLATE, STRIP GUIDE	24
-	1	-	-	-	-	690472-2	STRIPPER	22
-	1	1	1	1	-	2-21000-7	SCR, SKT HD CAP 8-32 X .500	21
-	4	4	4	4	-	21024-4	WASHER, SPRG LOCK, REG NO 8	20
-	-	-	-	-	-	691353-1	STRIPPER	19
△	-	-	-	-	-	679625-1	SHEAR HOLDER, FRONT (NO CUT)	13
△	-	-	-	-	-	3-22280-3	SPRING, COMPRESSION	12
△	-	-	-	-	-	690461-1	STOP, SHEAR	11
△	-	-	-	-	-	690459-1	SHEAR HOLDER, FRONT	10
△	-	-	-	-	-	454276-1	FLOATING SHEAR, FRONT	9
△	1	1	1	1	-	2-1633110-1	ANVIL, COMBINATION .090	8
-	-	-	-	-	..	-	-	7
-	-	-	-	-	..	-	-	6
-	1	1	1	1	-	1-455889-4	DEPRESSOR, SHEAR	5
-	1	1	1	1	-	238011-4	BLOCK, CRIMPER SPACER	4
△	1	1	1	1	-	3-683453-1	CRIMPER, INSULATION PREMIUM	3
△	1	1	1	1	-	455888	SPACER, CRIMPER	2
△	1	1	1	1	-	3-456406-3	CRIMPER, WIRE PREMIUM	1

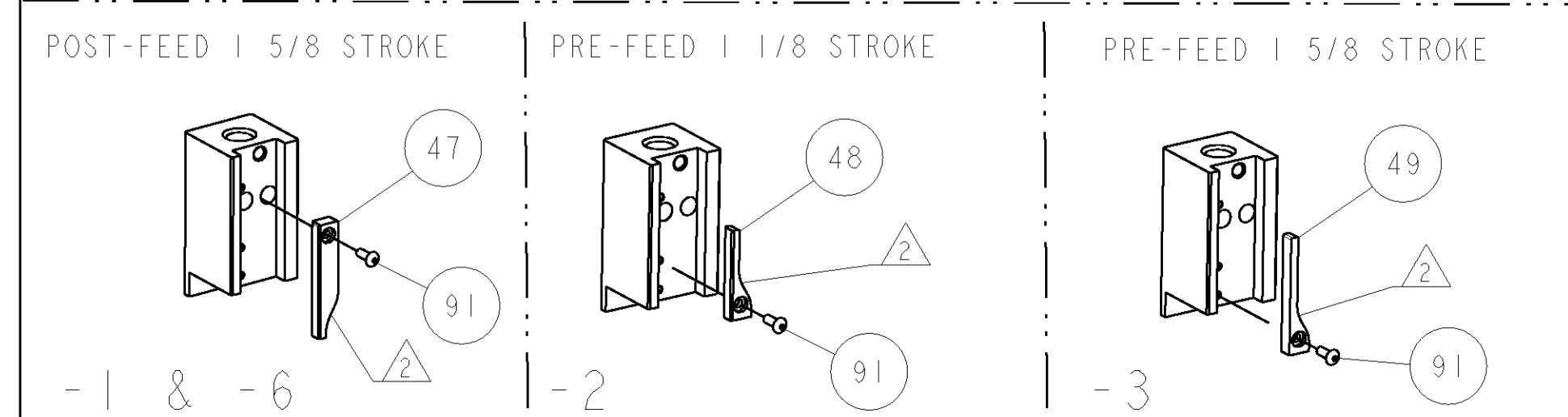

DIMENSIONS:		TOLERANCES UNLESS OTHERWISE SPECIFIED:		CUSTOMER DRAWING	
INCHES	0 PLC ±.01	1 PLC ±.01	2 PLC ±.01	3 PLC ±.001	4 PLC ±.0001
ANGLES	±.0001				
MATERIAL	FINISH	WEIGHT	SCALE	SHEET	REV
-	-	-	3:5	1	A

CUSTOMER VIEWABLE ASSEMBLY