

Important notice

Dear Customer,

On 7 February 2017 the former NXP Standard Product business became a new company with the tradename **Nexperia**. Nexperia is an industry leading supplier of Discrete, Logic and PowerMOS semiconductors with its focus on the automotive, industrial, computing, consumer and wearable application markets

In data sheets and application notes which still contain NXP or Philips Semiconductors references, use the references to Nexperia, as shown below.

Instead of <http://www.nxp.com>, <http://www.philips.com/> or <http://www.semiconductors.philips.com/>, use <http://www.nexperia.com>

Instead of sales.addresses@www.nxp.com or sales.addresses@www.semiconductors.philips.com, use salesaddresses@nexperia.com (email)

Replace the copyright notice at the bottom of each page or elsewhere in the document, depending on the version, as shown below:

- © NXP N.V. (year). All rights reserved or © Koninklijke Philips Electronics N.V. (year). All rights reserved

Should be replaced with:

- © **Nexperia B.V. (year). All rights reserved.**

If you have any questions related to the data sheet, please contact our nearest sales office via e-mail or telephone (details via salesaddresses@nexperia.com). Thank you for your cooperation and understanding,

Kind regards,

Team Nexperia

DATA SHEET

For a complete data sheet, please also download:

- The IC06 74HC/HCT/HCU/HCMOS Logic Family Specifications
- The IC06 74HC/HCT/HCU/HCMOS Logic Package Information
- The IC06 74HC/HCT/HCU/HCMOS Logic Package Outlines

74HC/HCT4515

**4-to-16 line decoder/demultiplexer
with input latches; inverting**

Product specification
File under Integrated Circuits, IC06

September 1993

4-to-16 line decoder/demultiplexer with input latches; inverting

74HC/HCT4515

FEATURES

- Inverting outputs
- Output capability: standard
- I_{CC} category: MSI

GENERAL DESCRIPTION

The 74HC/HCT4515 are high-speed Si-gate CMOS devices and are pin compatible with "4515" of the "4000B" series. They are specified in compliance with JEDEC standard no. 7A.

The 74HC/HCT4515 are 4-to-16 line decoders/demultiplexers having four binary weighted address inputs (A₀ to A₃) with latches, a latch enable input (LE), and an active LOW enable input (\bar{E}). The 16 inverting outputs (\bar{Q}_0 to \bar{Q}_{15}) are mutually exclusive active LOW. When LE is HIGH, the selected output is determined by the data on A_n. When LE goes LOW, the last data present at A_n are stored in the latches and the outputs remain stable. When \bar{E} is LOW, the selected output, determined by the contents of the latch, is LOW. When \bar{E} is HIGH, all outputs are HIGH. The enable input (\bar{E}) does not affect the state of the latch.

When the "4515" is used as a demultiplexer, \bar{E} is the data input and A₀ to A₃ are the address inputs.

QUICK REFERENCE DATA

GND = 0 V; T_{amb} = 25 °C; t_r = t_f = 6 ns

SYMBOL	PARAMETER	CONDITIONS	TYPICAL		UNIT
			HC	HCT	
t _{PHL} / t _{PLH}	propagation delay A _n to \bar{Q}_n	C _L = 15 pF; V _{CC} = 5 V	25	26	ns
C _I	input capacitance		3.5	3.5	pF
C _{PD}	power dissipation capacitance per package	notes 1 and 2	44	46	pF

Notes

1. C_{PD} is used to determine the dynamic power dissipation (P_D in μW):

$$P_D = C_{PD} \times V_{CC}^2 \times f_i + \sum (C_L \times V_{CC}^2 \times f_o) \text{ where:}$$

f_i = input frequency in MHz

f_o = output frequency in MHz

∑ (C_L × V_{CC}² × f_o) = sum of outputs

C_L = output load capacitance in pF

V_{CC} = supply voltage in V

2. For HC the condition is V_I = GND to V_{CC}
For HCT the condition is V_I = GND to V_{CC} – 1.5 V

ORDERING INFORMATION

See "74HC/HCT/HCU/HCMOS Logic Package Information".

4-to-16 line decoder/demultiplexer with input latches; inverting

74HC/HCT4515

PIN DESCRIPTION

PIN NO.	SYMBOL	NAME AND FUNCTION
1	LE	latch enable input (active HIGH)
2, 3, 21, 22	A ₀ to A ₃	address inputs
11, 9, 10, 8, 7, 6, 5, 4, 18, 17, 20, 19, 14, 13, 16, 15	\bar{Q}_0 to \bar{Q}_{15}	multiplexer outputs (active LOW)
12	GND	ground (0 V)
23	\bar{E}	enable input (active LOW)
24	V _{CC}	positive supply voltage

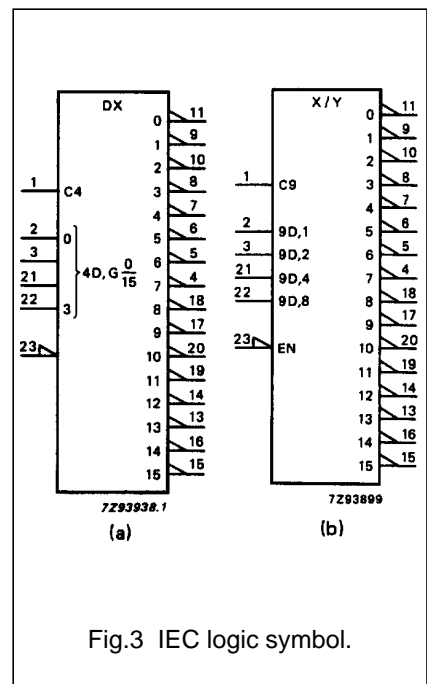
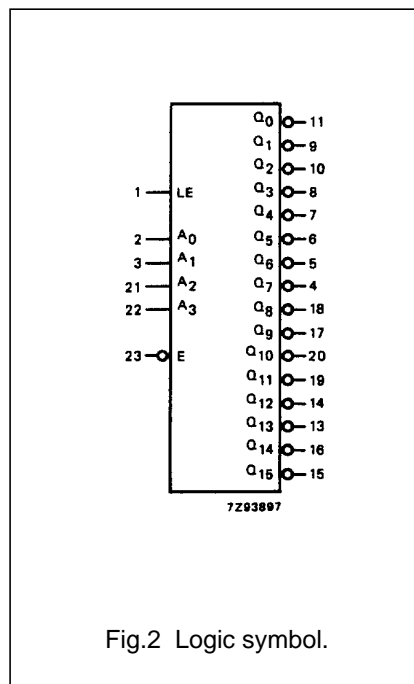
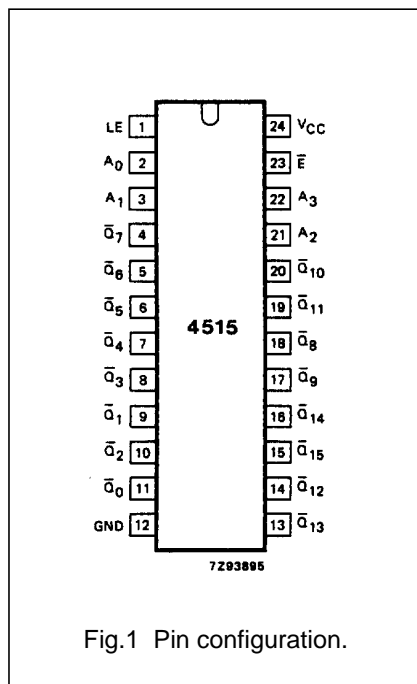

4-to-16 line decoder/demultiplexer with input latches; inverting

74HC/HCT4515

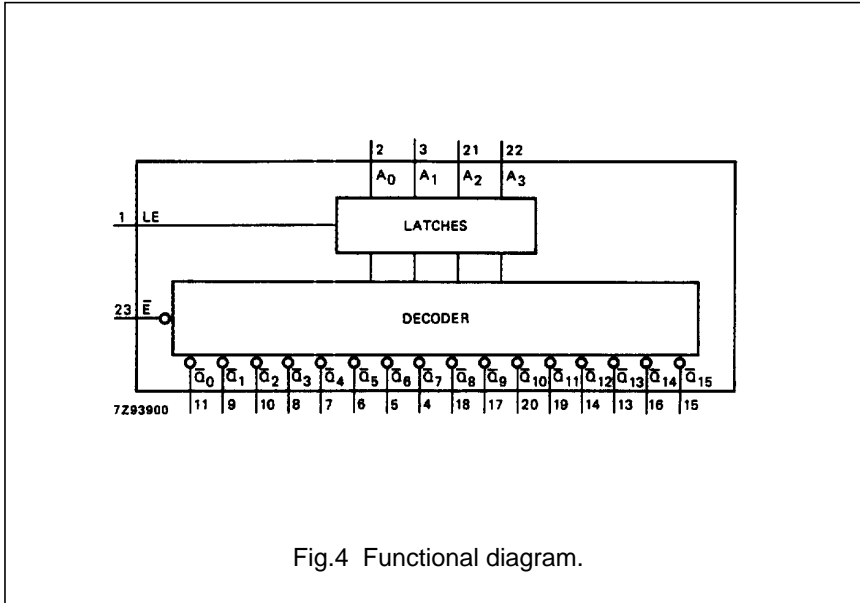

Fig.4 Functional diagram.

APPLICATIONS

- Digital multiplexing
- Address decoding
- Hexadecimal/BCD decoding

FUNCTION TABLE

INPUTS					OUTPUTS																
\bar{E}	A ₀	A ₁	A ₂	A ₃	\bar{Q}_0	\bar{Q}_1	\bar{Q}_2	\bar{Q}_3	\bar{Q}_4	\bar{Q}_5	\bar{Q}_6	\bar{Q}_7	\bar{Q}_8	\bar{Q}_9	\bar{Q}_{10}	\bar{Q}_{11}	\bar{Q}_{12}	\bar{Q}_{13}	\bar{Q}_{14}	\bar{Q}_{15}	
H	X	X	X	X	H	H	H	H	H	H	H	H	H	H	H	H	H	H	H	H	H
L	L	L	L	L	L	H	H	H	H	H	H	H	H	H	H	H	H	H	H	H	H
L	H	L	L	L	H	L	H	H	H	H	H	H	H	H	H	H	H	H	H	H	H
L	L	H	L	L	H	H	L	H	H	H	H	H	H	H	H	H	H	H	H	H	H
L	H	H	L	L	H	H	H	H	L	H	H	H	H	H	H	H	H	H	H	H	H
L	L	L	H	L	H	H	H	H	H	L	H	H	H	H	H	H	H	H	H	H	H
L	H	L	H	L	H	H	H	H	H	L	H	H	H	H	H	H	H	H	H	H	H
L	L	H	H	L	H	H	H	H	H	H	L	H	H	H	H	H	H	H	H	H	H
L	H	H	H	L	H	H	H	H	H	H	H	L	H	H	H	H	H	H	H	H	H
L	L	L	L	H	H	H	H	H	H	H	H	H	L	H	H	H	H	H	H	H	H
L	H	L	H	H	H	H	H	H	H	H	H	H	H	L	H	H	H	H	H	H	H
L	L	H	H	H	H	H	H	H	H	H	H	H	H	H	L	H	H	H	H	H	H
L	H	H	H	H	H	H	H	H	H	H	H	H	H	H	H	L	H	H	H	H	H

Notes

1. LE = HIGH
 H = HIGH voltage level
 L = LOW voltage level
 X = don't care

4-to-16 line decoder/demultiplexer with
input latches; inverting

74HC/HCT4515

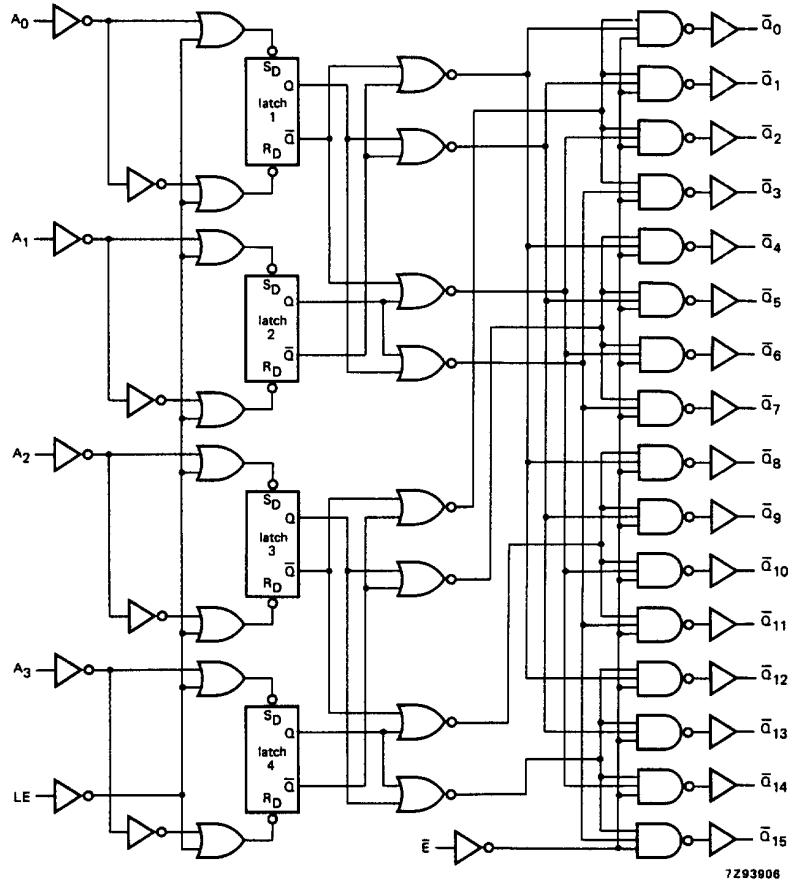

Fig.5 Logic diagram.

4-to-16 line decoder/demultiplexer with input latches; inverting

74HC/HCT4515

DC CHARACTERISTICS FOR 74HC

For the DC characteristics see *"74HC/HCT/HCU/HCMOS Logic Family Specifications"*.

Output capability: standard

I_{CC} category: MSI

AC CHARACTERISTICS FOR 74HC

GND = 0 V; t_r = t_f = 6 ns; C_L = 50 pF

SYMBOL	PARAMETER	T _{amb} (°C)						UNIT	TEST CONDITIONS		
		74HC							V _{CC} (V)	WAVEFORMS	
		+25			-40 to +85		-40 to +125				
		min.	typ.	max.	min.	max.	min.				max.
t _{PHL} / t _{PLH}	propagation delay A _n to \overline{Q}_n		80 29 23	250 50 43		315 63 54		375 75 64	ns	2.0 4.5 6.0	Fig.6
t _{PHL} / t _{PLH}	propagation delay LE to \overline{Q}_n		66 24 19	225 45 38		280 56 48		340 68 58	ns	2.0 4.5 6.0	Fig.6
t _{PHL} / t _{PLH}	propagation delay \overline{E} to \overline{Q}_n		50 18 14	175 35 30		220 44 37		265 53 45	ns	2.0 4.5 6.0	Fig.6
t _{THL} / t _{TLH}	output transition time		19 7 6	75 15 13		95 19 16		110 22 19	ns	2.0 4.5 6.0	Fig.6
t _W	latch enable pulse width HIGH	75 15 13	14 5 4		95 19 16		110 22 19		ns	2.0 4.5 6.0	Fig.7
t _{SU}	set-up time A _n to LE	90 18 15	28 10 8		115 23 20		135 27 23		ns	2.0 4.5 6.0	Fig.7
t _H	hold time A _n to LE	0 0 0	-11 -4 -3		0 0 0		0 0 0		ns	2.0 4.5 6.0	Fig.7

4-to-16 line decoder/demultiplexer with input latches; inverting

74HC/HCT4515

DC CHARACTERISTICS FOR 74HCT

For the DC characteristics see *"74HC/HCT/HCU/HCMOS Logic Family Specifications"*.

Output capability: standard

I_{CC} category: MSI

Note to HCT types

The value of additional quiescent supply current (ΔI_{CC}) for a unit load of 1 is given in the family specifications.

To determine ΔI_{CC} per input, multiply this value by the unit load coefficient shown in the table below.

INPUT	UNIT LOAD COEFFICIENT
A _n	0.65
LE	1.40
\bar{E}	1.00

AC CHARACTERISTICS FOR 74HCT

GND = 0 V; t_r = t_f = 6 ns; C_L = 50 pF

SYMBOL	PARAMETER	T _{amb} (°C)							UNIT	TEST CONDITIONS		
		74HCT								V _{CC} (V)	WAVEFORMS	
		+25			-40 to +85		-40 to +125					
		min.	typ.	max.	min.	max.	min.	max.				
t _{PHL} / t _{PLH}	propagation delay A _n to \bar{Q}_n		30	55		69		83	ns	4.5	Fig.6	
t _{PHL} / t _{PLH}	propagation delay LE to \bar{Q}_n		29	50		63		75	ns	4.5	Fig.6	
t _{PHL} / t _{PLH}	propagation delay \bar{E} to \bar{Q}_n		18	40		50		60	ns	4.5	Fig.6	
t _{THL} / t _{TLH}	output transition time		7	15		19		22	ns	4.5	Fig.6	
t _w	latch enable pulse width HIGH	16	3		20		24		ns	4.5	Fig.7	
t _{su}	set-up time A _n to LE	18	9		23		27		ns	4.5	Fig.7	
t _h	hold time A _n to LE	3	-2		3		3		ns	4.5	Fig.7	

4-to-16 line decoder/demultiplexer with input latches; inverting

74HC/HCT4515

AC WAVEFORMS

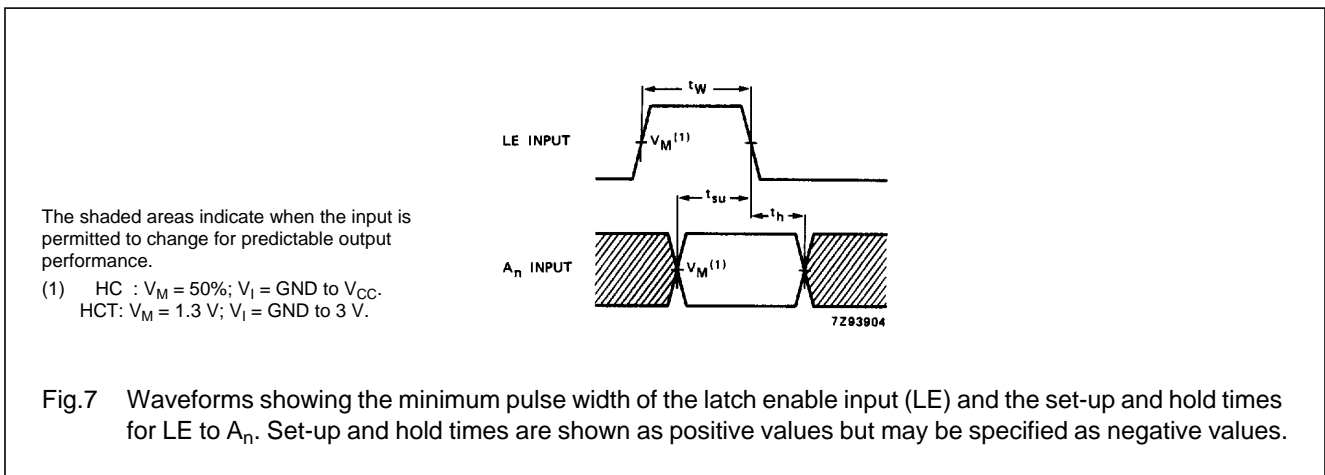
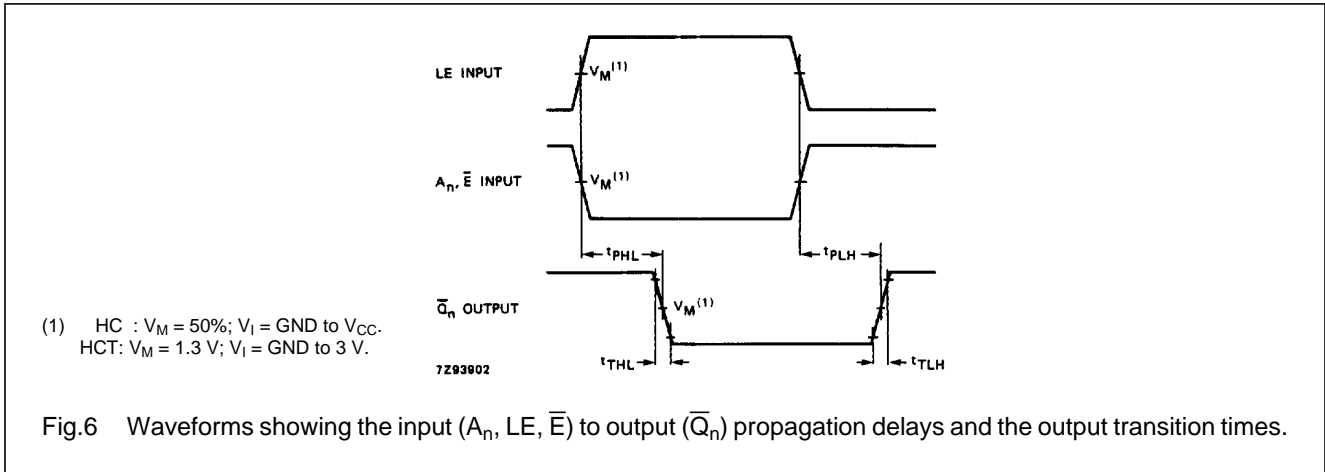

PACKAGE OUTLINES

See "74HC/HCT/HCU/HCMOS Logic Package Outlines".