

Series 448

Commercial Linear Motion

Carbon Composition Slide Potentiometer

- 10-60mm slider travel
- Innovative AC power switch (SPST, SPDT)
- Center detent available
- Single or dual element designs
- Economical
- Wide resistance range
- Slim construction
- RoHS compliant

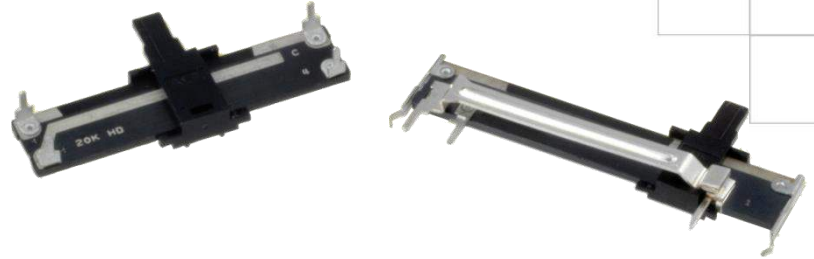

Description

The versatile 448 Series provides the designer with a thin construction and multiple mounting options. As a standard construction, the 448 series is available with the actuator parallel or perpendicular to PC board. Options include various actuator lengths, terminal styles, resistance values, and travel options to meet your design requirements.

Ordering Information

Series	Mounting Style	Travel	Actuator Style	Resistance Code Examples	Resistance Tolerance	Taper	Specials
448	U	E	2	102	B	D	N
Code	Spec.	U & X Mounting		Code		Code	
U	Actuator parallel to PC board	2 - Style A	9.5mm	A	±10%	N	No specials
X	Actuator perpendicular to PC board	3 - Style B	4.0mm	B	±20%	C	Center detent
V	Actuator (Low profile) perpendicular to PCB (mono only)	4 - Style C	5.0mm	C	±30%	S	SPST power switch (20 & 30mm X type only)
		V Mounting		Code		D	
		1 - Style D	3.35mm	501	500 ohms	SPDT power switch (20mm X type and 9.5mm actuator only)	
		U & X Mounting Style		Resistance		Code	
		A	10mm	102	1K	D	Linear
		B	15mm	502	5K	A	CW 10% AUD
		C	20mm	103	10K	B	CCW 10% AUD
		D	30mm	104	100K		
		E	45mm				
		F	60mm				
		V Mounting Style					
		A	10mm				
		B	15mm				
		C	25mm				
		D	40mm				
		E	55mm				

Electrical Specifications

Parameter	Conditions & Remarks	Min.	Max.	Unit		
Resistance Range	Linear (Audio - consult CTS)	500	1 Meg	ohms		
Resistance Tolerance	±30%, ±20%, ±10%					
Insulation Resistance	at 250 VDC	10 Meg		ohms		
Maximum Operating Voltage	Taper	10mm	15mm 20mm	30mm	45mm	60mm
	Linear	100VDC	150VDC 200VDC	250VDC	300VDC	500VDC
	Non-linear	50VDC	50VDC 150VDC	200VDC	250VDC	300VDC
Power Rating, watts	Taper	10mm	15mm 20mm	30mm	45mm	60mm
	Linear	0.05w	0.1w	0.2w	0.25w	0.5w
	Non-linear	0.025w	0.05w	0.1w	0.15w	0.25w

Mechanical and Environmental

Power Switch (optional)	SPST 10,000 cycles carrying 1,000 watts 120 VAC (Tungsten-filament) SPDT 10,000 cycles carrying 600 watts 120 VAC (Tungsten-filament)
Slide Travel (without switch)	X and U Style: 10, 15, 20, 30, 45, and 60mm V Style: 10, 15, 25, 40 and 55mm
Slide Travel (with switch)	30mm= 27mm electrical+3mm switch (SPST only) 20mm= 17mm electrical+3mm switch
Power Switch (optional)	SPST 10,000 cycles carrying 1,000 watts 120 VAC (Tungsten-filament) SPDT 10,000 cycles carrying 600 watts 120 VAC (Tungsten-filament)
Operating Force	Potentiometer: 20-150g Switch: 100-500g
Stop Strength	3 Kgf maximum, measured at base of slider
Operating Life	Standard: 10,000 cycles Special:100,000, 250,000 cycles
Reflow Soldering	Maximum temperature of 260°C for 5 seconds
RoHS	Lead-Free. Fully compliant to RoHS Directive
Packaging :	Standard sample box packaging
Operating Temperature Range	-40 °C to +85 °C

Mechanical Specifications

Figure 1 – 448V Mono

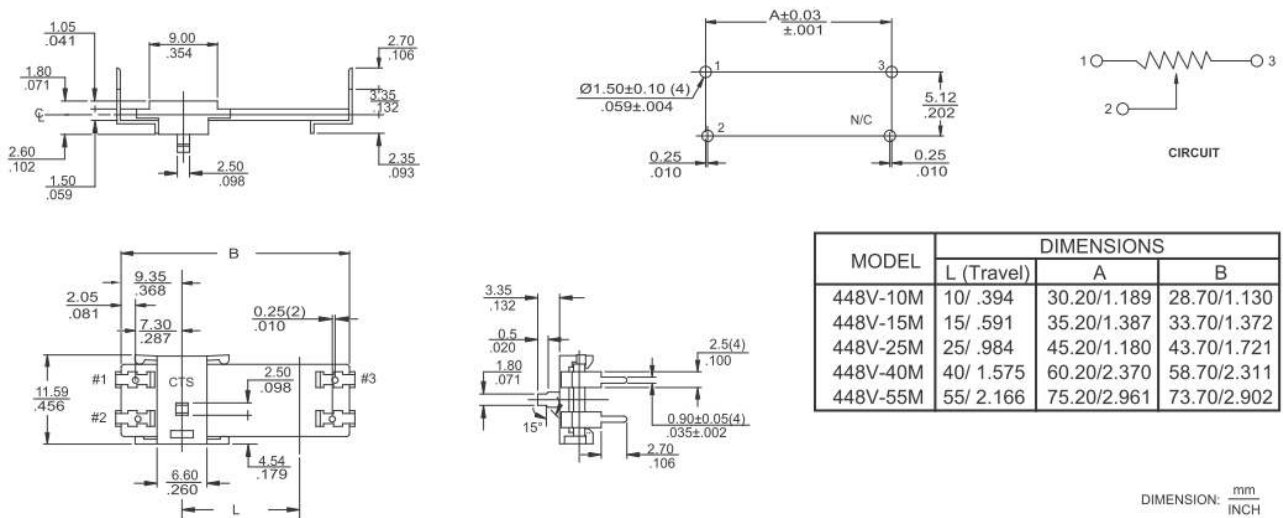

Figure 2 – 448U Mono

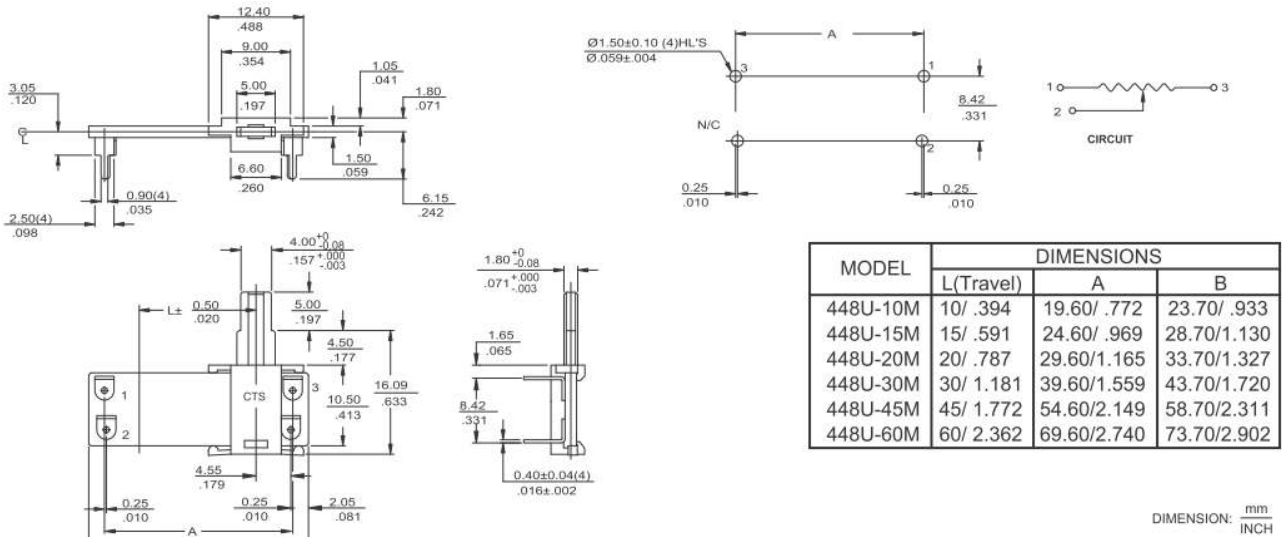

Figure 3 – 448U Dual

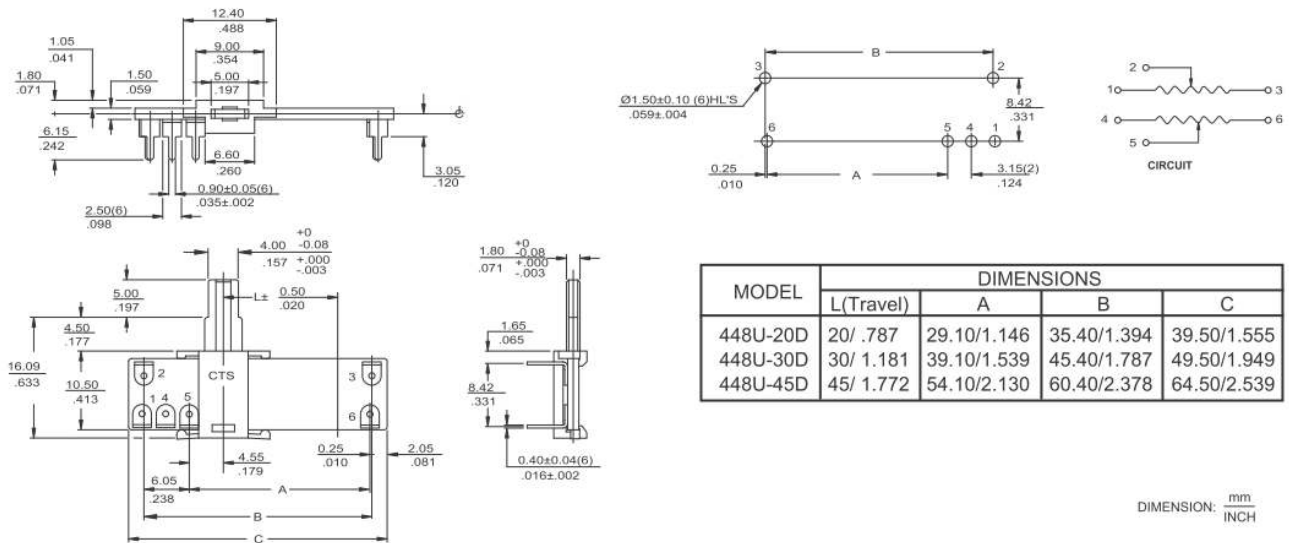

Figure 4 – 448X Mono

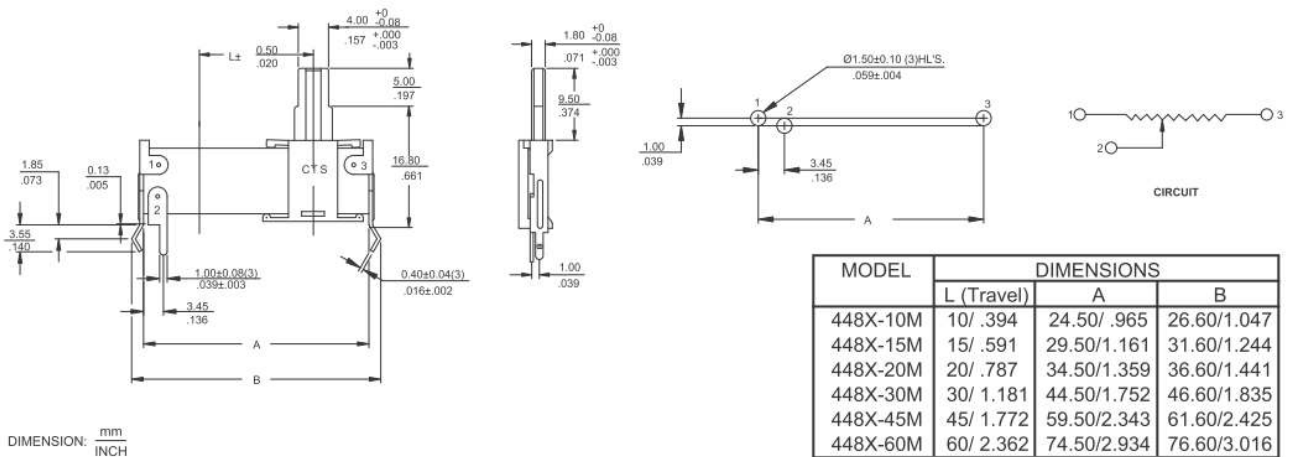

Figure 5 – 448X Dual

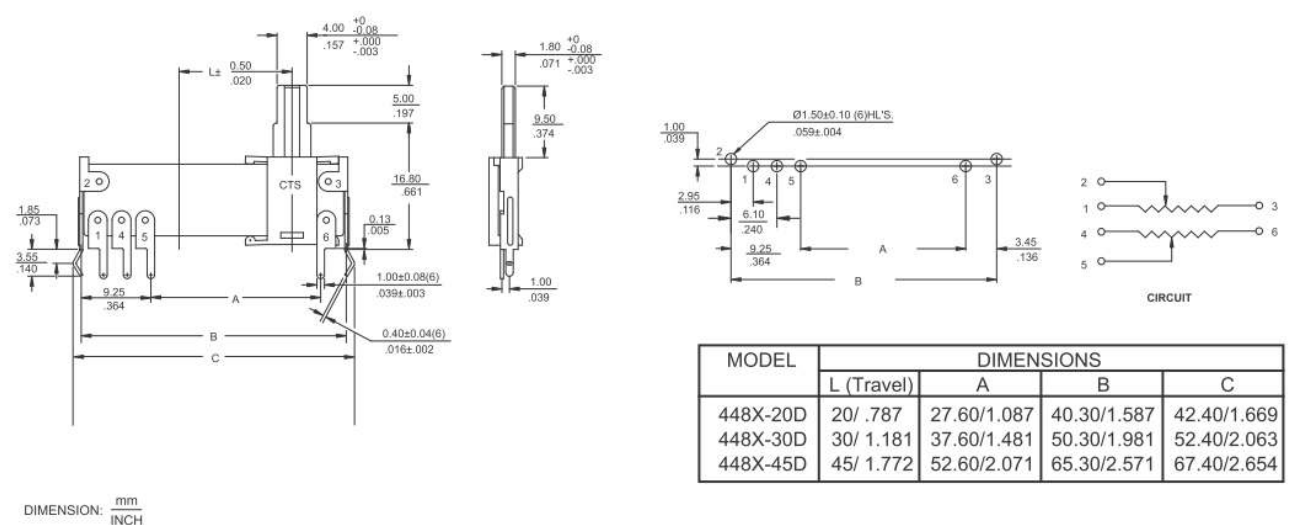

Figure 6 – 448X Mono W/SPST Switch

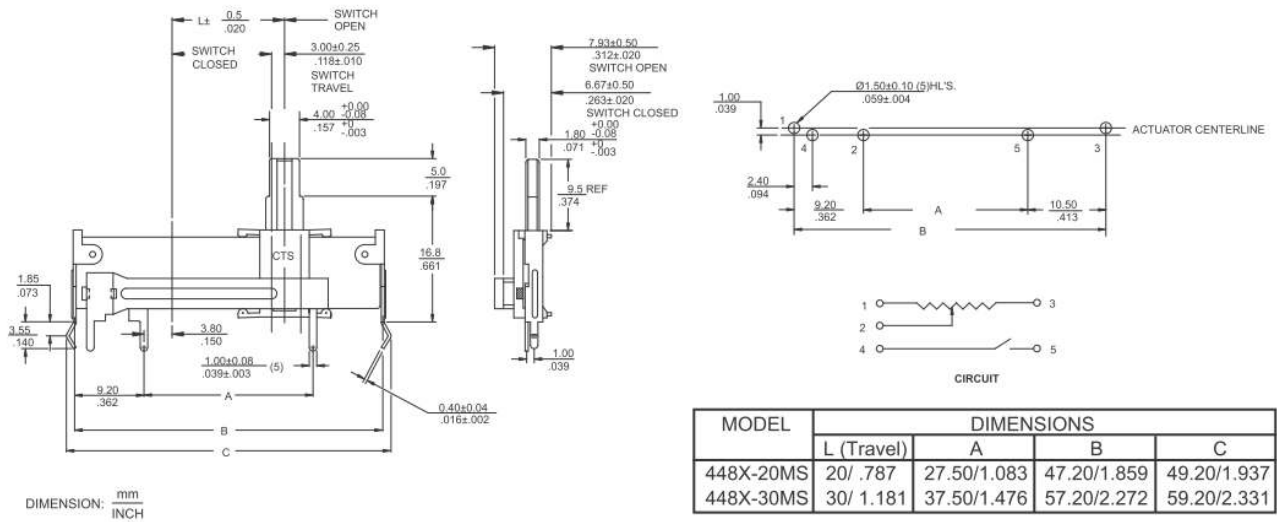
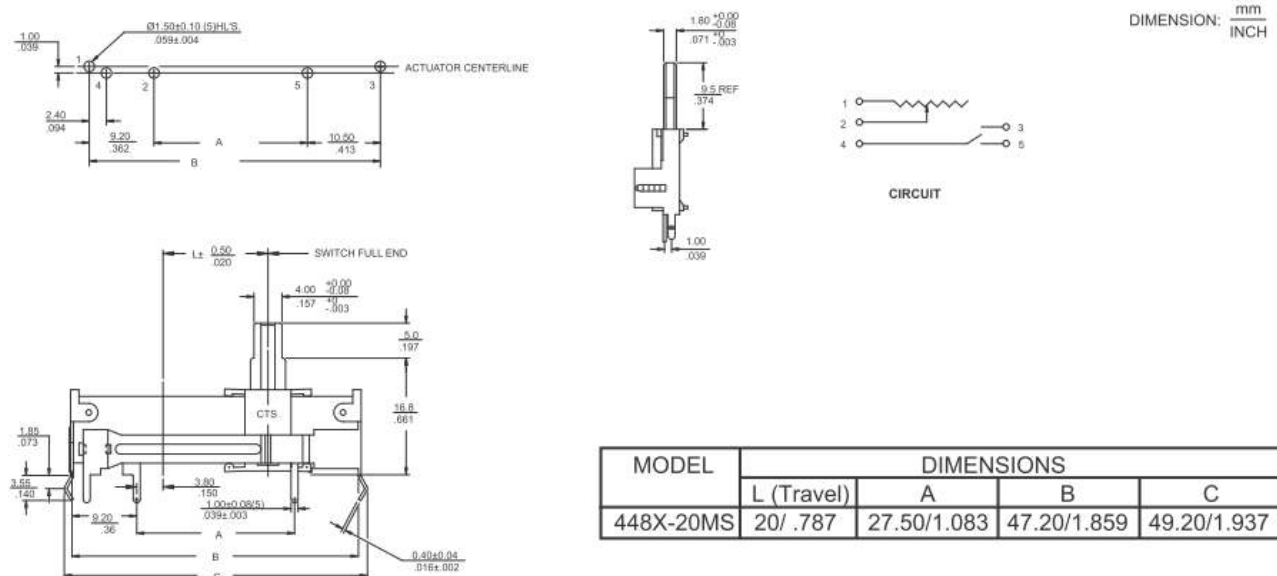

Figure 7 – 448X Mono W/SPDT Switch (with style A actuator only)



448 Series Actuator Styles

