

## High brightness LED array driver based on the STP16CPC26

Data brief



### Description

The STEVAL-ILL062V1 evaluation board is a high brightness LED array driver application based on the 16 channel, constant current LED sink driver STP16CPC26 from STMicroelectronics.

The LED driver is configured and controlled through an 8-bit STM8S microcontroller via SPI interface.

The industrial-grade L7981D DC-DC converter provides the voltages and power for the overall functioning of the board.

### Features

- Demonstrates pre-configured patterns (with adjustable brightness/speed) such as rolling text, wave effect, dot sequence, etc.
- LED test points
- Potentiometer to change brightness and speed of patterns
- SWIM connector to program microcontroller
- Push buttons (backward/forward) to change between modes
- DC supply connector: 6 V - 24 V
- 32 white LEDs
- RoHS compliant

# 1 Schematic diagrams

Figure 1. Power section

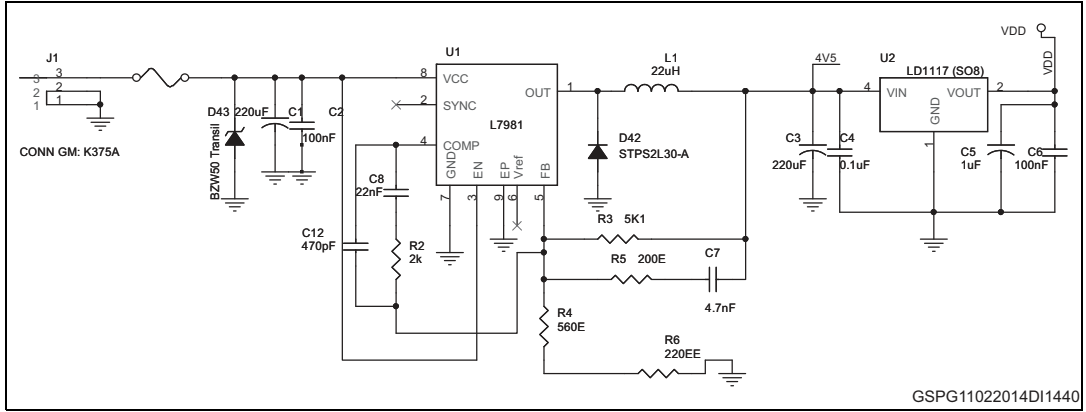

Figure 2. Microcontroller

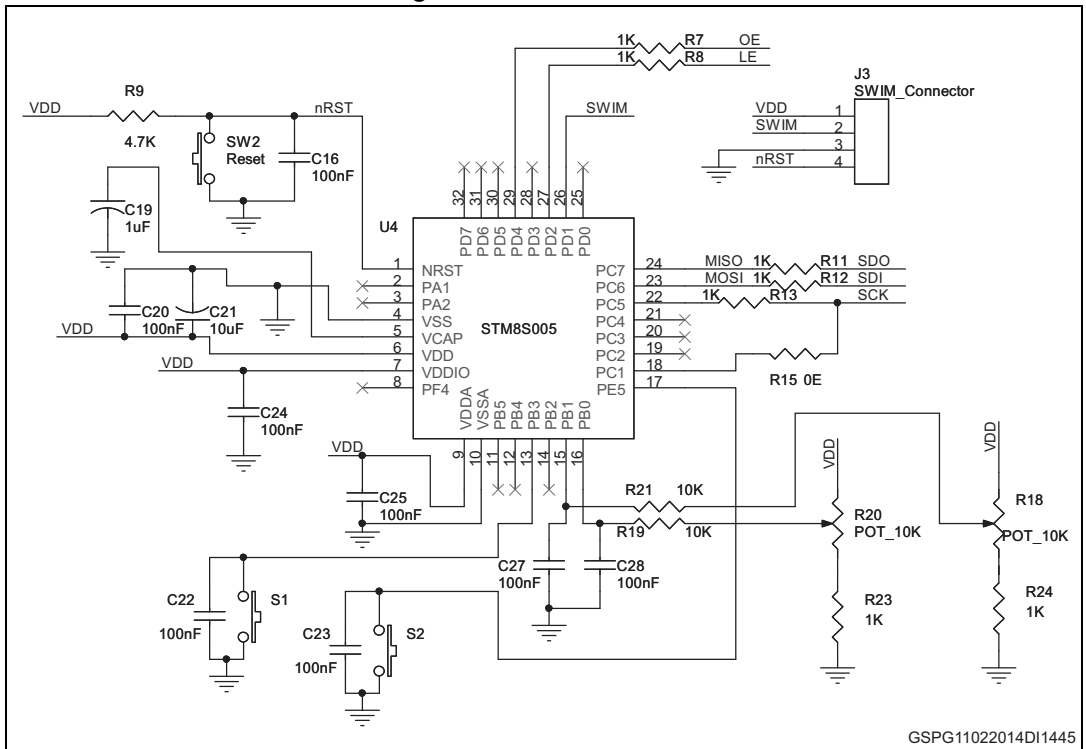

Figure 3. Jumpers to simulate open circuit

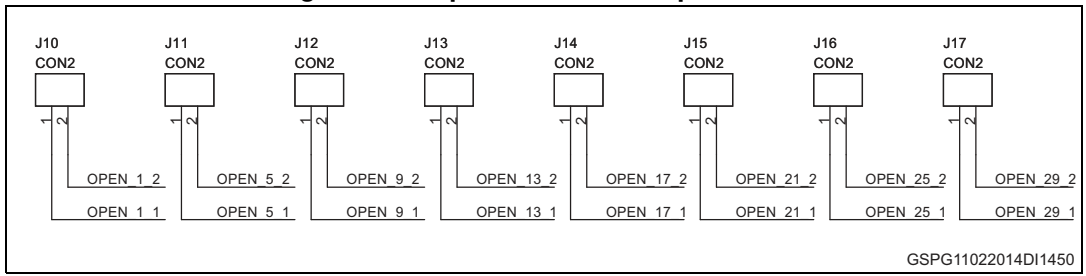
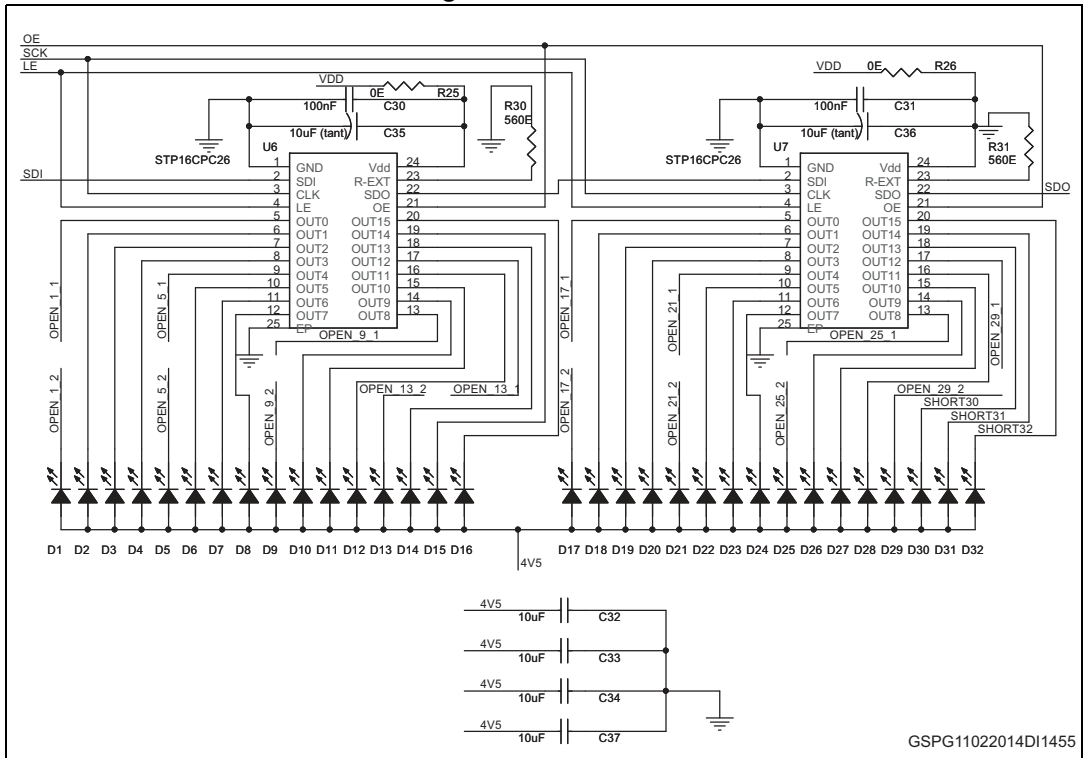

Figure 4. LED driver



## 2 Revision history

Table 1. Document revision history

Date	Revision	Changes
07-Aug-2014	1	Initial release.

**IMPORTANT NOTICE – PLEASE READ CAREFULLY**

STMicroelectronics NV and its subsidiaries ("ST") reserve the right to make changes, corrections, enhancements, modifications, and improvements to ST products and/or to this document at any time without notice. Purchasers should obtain the latest relevant information on ST products before placing orders. ST products are sold pursuant to ST's terms and conditions of sale in place at the time of order acknowledgement.

Purchasers are solely responsible for the choice, selection, and use of ST products and ST assumes no liability for application assistance or the design of Purchasers' products.

No license, express or implied, to any intellectual property right is granted by ST herein.

Resale of ST products with provisions different from the information set forth herein shall void any warranty granted by ST for such product.

ST and the ST logo are trademarks of ST. All other product or service names are the property of their respective owners.

Information in this document supersedes and replaces information previously supplied in any prior versions of this document.

© 2014 STMicroelectronics – All rights reserved

