

## SMA Clamp Type Right Angle Plugs for Flexible Cable

1. Identify connector parts. (4 piece parts)
2. Strip cable to dimensions shown. Do not nick braid or center conductor. A wire stripper of correct size is recommended for this step. Twist stranded center conductor into tight bundle and tin (optional). Slide clamp nut and clamp cone onto cable as shown. Clamp cone must be oriented as shown for each size of cable. The RG-58/142 clamp cone slides over braid and against jacket.
3. Flare braid and slide cable into body making certain that the cable insulation bottoms on center contact. Stepped down diameter of stem must slide under braid and jacket. Arrange braid uniformly around crimp stem. Slide clamp nut against clamp cone and braid and tighten to 10 in.-lb. torque.
4. Solder center conductor to contact through the rear access port. Use a minimum amount of solder for a full fillet joint. .020 (0.51) diameter solder is recommended. Place expansion cap in access port and seat with .187 (4.75) diameter flat punch.

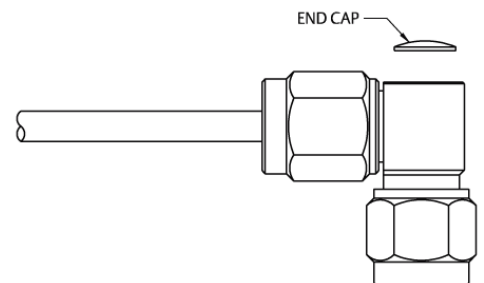
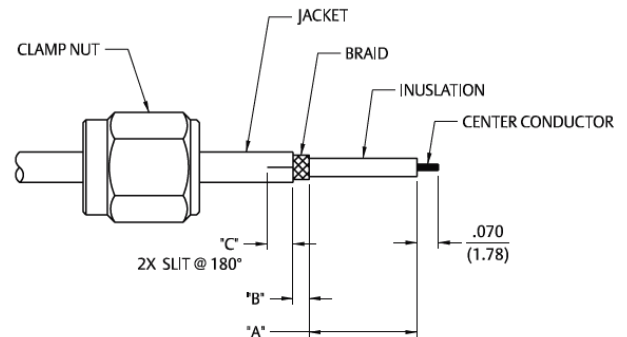
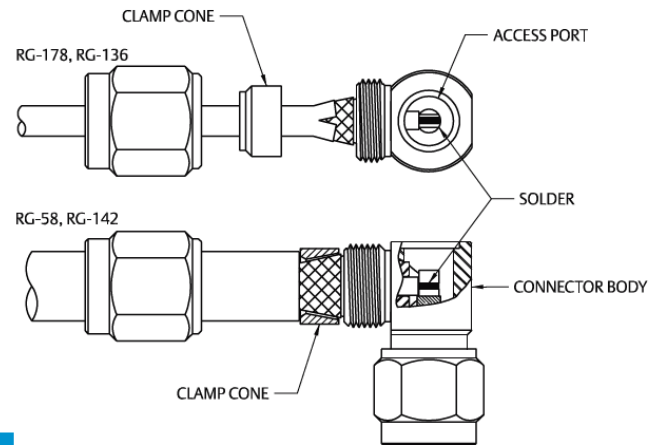
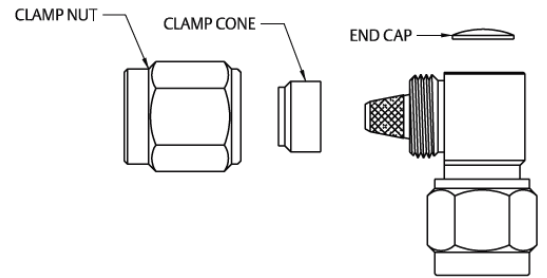

Cable Group	Part No.	"A"	"B"	"C"
RG-178/U, 196	142-0202-101	.280 (7.11)	.053 (1.35)	.085 (2.16)
	142-0202-106	.280 (7.11)	.053 (1.35)	.085 (2.16)
RG-316/U, 161, 174, 188	142-0203-101	.280 (7.11)	.053 (1.35)	.085 (2.16)
	142-0203-106	.280 (7.11)	.053 (1.35)	.085 (2.16)
RG-58/U 141, 303	142-0207-101	.395 (10.03)	.160 (4.06)	NONE
	142-0207-106	.395 (10.03)	.160 (4.06)	NONE
RG-55/U, 142, 233, 400	142-0207-101	.420 (10.67)	.180 (4.57)	NONE
	142-0207-106	.420 (10.67)	.180 (4.57)	NONE