

THIS DRAWING IS UNPUBLISHED. RELEASED FOR PUBLICATION 20
 © COPYRIGHT 20 BY - ALL RIGHTS RESERVED.

REVISIONS				
P	LTR	DESCRIPTION	DATE	APVD
A		RELEASED ECO-14-003843	31MAR2014	LAW SB

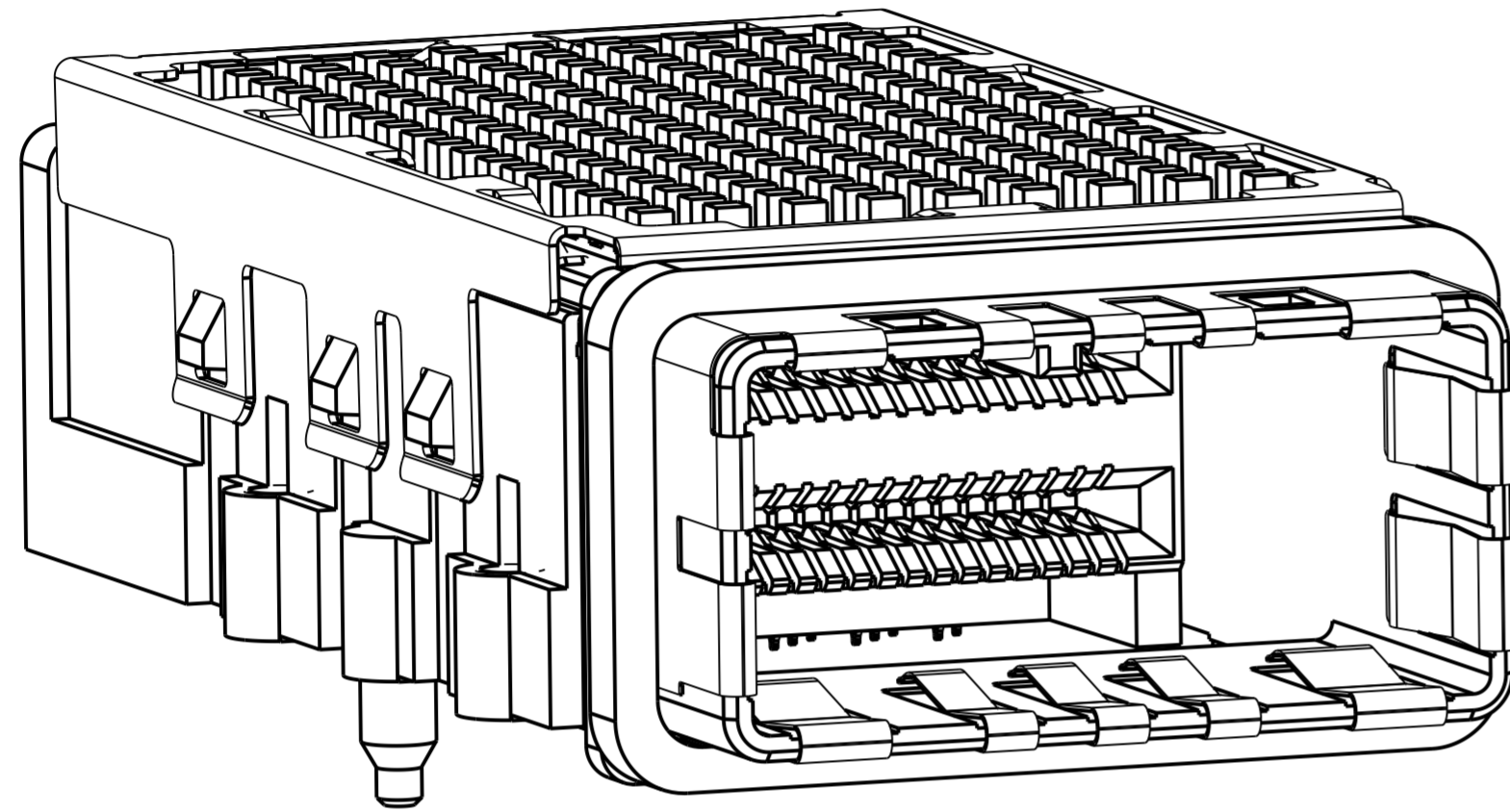

2149157-1
SCALE 5:1

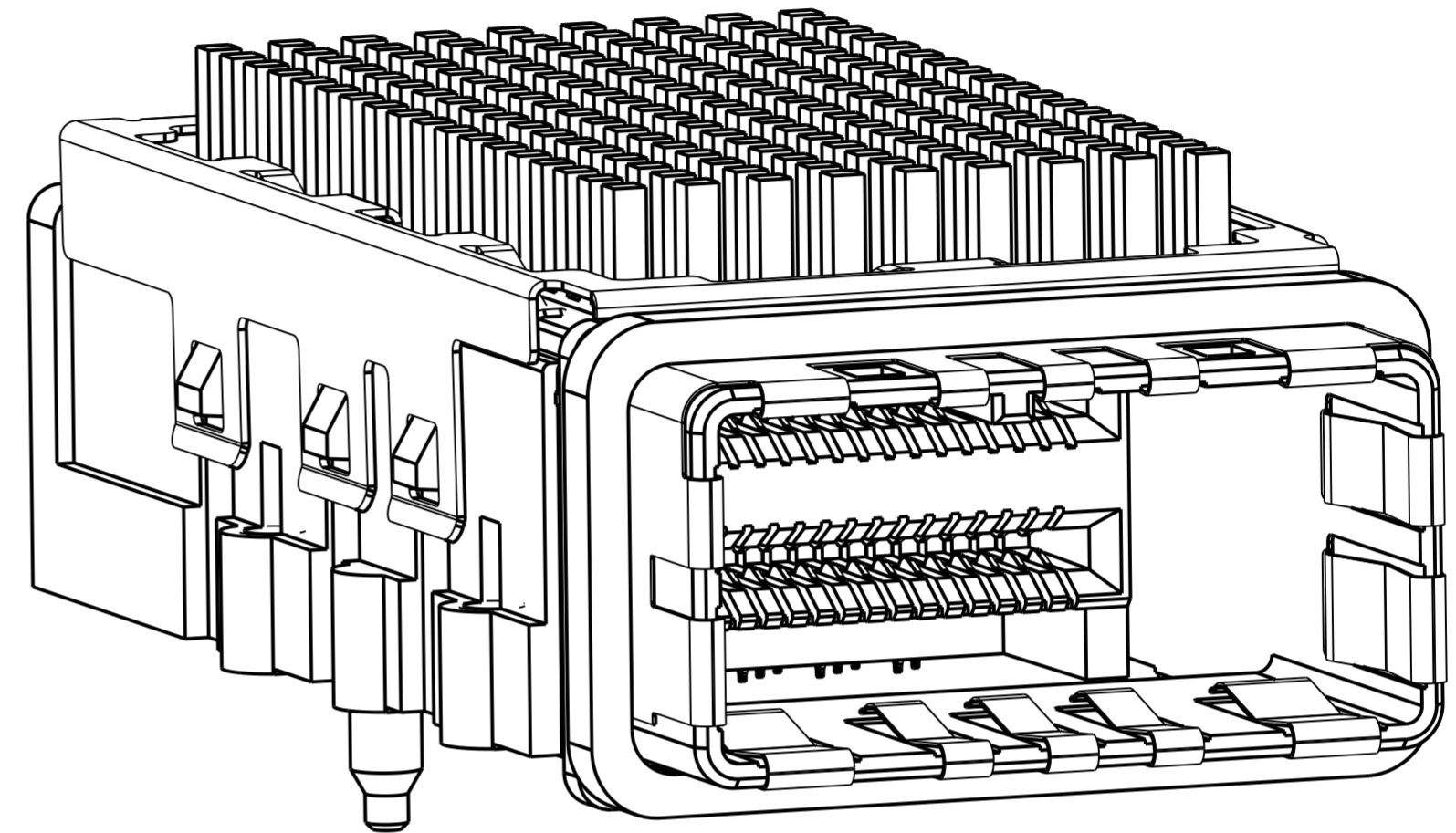

2149157-3
SCALE 5:1

OBSOLETE	23.5	2149448-2	3	84 POSITION RECEPTACLE ASSEMBLY WITH HEAT SINK	2149157-6
	23.5	2149448-1	2	84 POSITION RECEPTACLE ASSEMBLY WITH HEAT SINK	2149157-5
OBSOLETE	16.5	2149448-2	3	84 POSITION RECEPTACLE ASSEMBLY WITH HEAT SINK	2149157-4
	16.5	2149448-1	2	84 POSITION RECEPTACLE ASSEMBLY WITH HEAT SINK	2149157-3
OBSOLETE	14.2	2149448-2	3	84 POSITION RECEPTACLE ASSEMBLY WITH HEAT SINK	2149157-2
	14.2	2149448-1	2	84 POSITION RECEPTACLE ASSEMBLY WITH HEAT SINK	2149157-1
E		RECEPTACLE HOUSING SUB-ASSEMBLY	FINISH	DESCRIPTION	PART NUMBER

THIS DRAWING IS A CONTROLLED DOCUMENT. DIMENSIONING AND TOLERANCING PER ASME Y14.5M-2009

DIMENSIONS: mm

TOLERANCES UNLESS OTHERWISE SPECIFIED:

0 PLC	±0.15
1 PLC	±0.15
2 PLC	±0.15
3 PLC	±
4 PLC	±
ANGLES	±
FINISH	±

MATERIAL

DWN 09 JUN 2010
M. E. COWHER

CHK 10 JUN 2010
M. D. MORRISON

APVD 10 JUN 2010
M. D. MORRISON

PRODUCT SPEC 108-2426

APPLICATION SPEC 114-13283

WEIGHT -

Customer Drawing

STE TE Connectivity

NAME RECEPTACLE ASSEMBLY WITH HEAT SINK, 84 POSITION, CXP

SIZE CAGE CODE DRAWING NO RESTRICTED TO

A200779 C-2149157

SCALE 1:1 SHEET 1 OF 5 REV A

THIS DRAWING IS UNPUBLISHED. RELEASED FOR PUBLICATION 20
 © COPYRIGHT 20 BY - ALL RIGHTS RESERVED.

REVISIONS				
P	LTR	DESCRIPTION	DATE	APVD
-		SEE SHEET 1	-	-

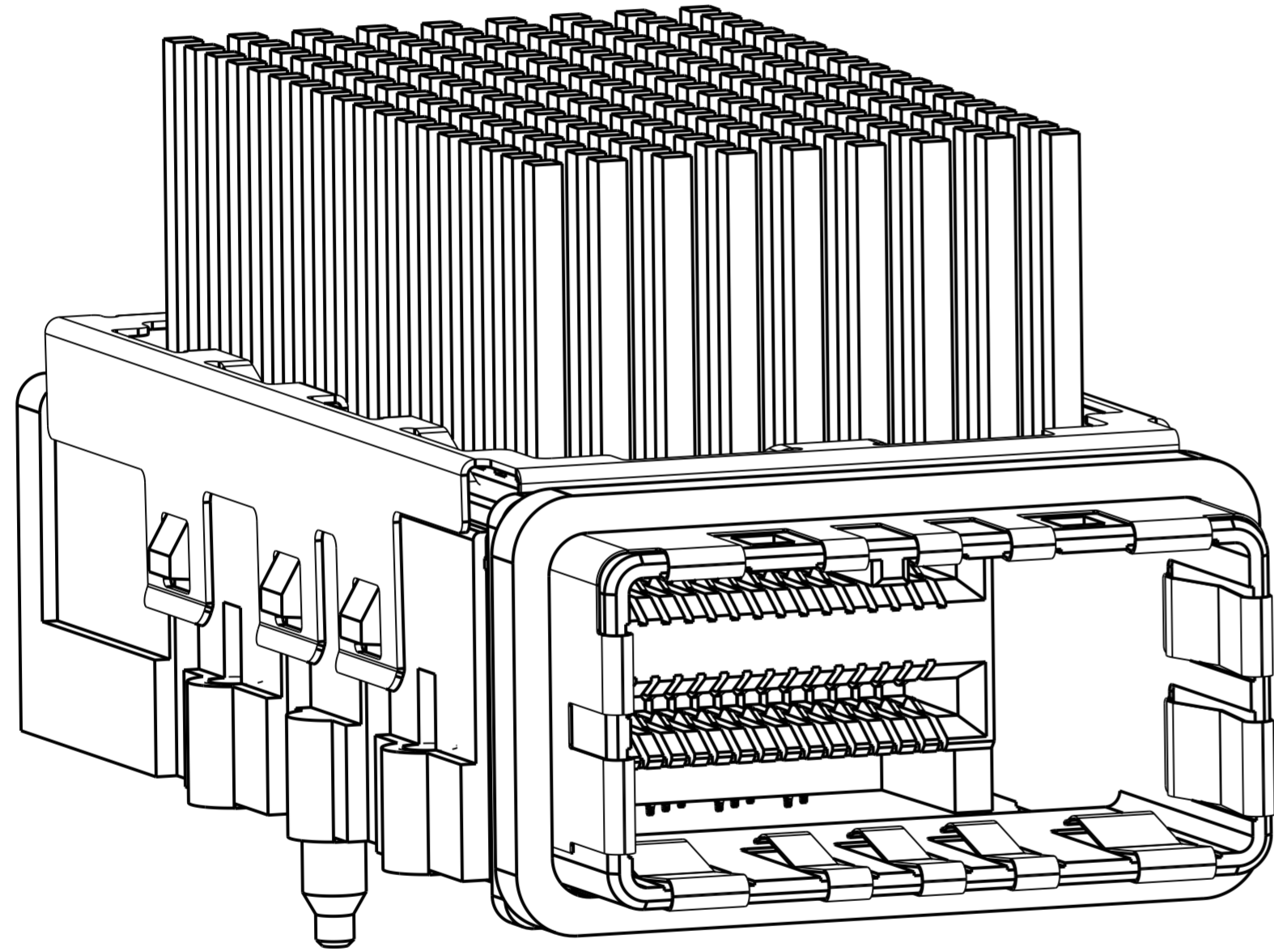

2149157-5
SCALE 5:1

- 1. MATERIALS:
 HOUSING - ZINC ALLOY
 EMI GASKET - CONDUCTIVE URETHANE FOAM
 RECEPTACLE HOUSING - LCP, BLACK, UL 94V-0 RATED
 CHICKLET - LCP, BLACK, UL 94V-0 RATED
 CONTACT - PHOSPHOR BRONZE
 EMI SPRING - COPPER ALLOY
 HEAT SINK - ALUMINUM
 CLIP, HEAT SINK - STAINLESS STEEL
- 2. FINISH:
 CONTACT-CONFORMS TO THE REQUIREMENTS OF TE
 PRODUCT SPECIFICATION 108-2426, BASED ON EIA/ECA-364-1000.01A,
 (CONTROLLED ENVIRONMENT APPLICATIONS) ON MATING INTERFACE,
 MATTE TIN PLATE OVER NICKEL UNDERPLATE ON COMPLAINT PIN
 HOUSING & HEATSINK - NICKEL PLATE
- 3. NOTE DELETED
- 4. PCB THICKNESS = 1.57 MIN
- 5. FOR HOLE SIZE AND FINISHES, SEE APPLICATION SPEC 114-13283
- 6. THE ENTIRE AREA OF THE CONNECTOR FOOTPRINT, INDICATED BY CROSSHATCHING, TO BE CONSIDERED THE KEEPOUT AREA FOR COMPONENTS AND SIGNAL TRACES, TOP SIDE ONLY, TOP SIDE TRACES ALLOWED WITHIN CONNECTOR HOLE PATTERN, CROSSHATCHING TO BE CONDUCTIVE
- 7. MOUNTING HARDWARE REQUIRED:
 M2x0.4 (4)
 MOUNTING SCREW LENGTH = BOARD THICKNESS PLUS 4mm MAX
- 8. COMPONENTS PACKAGED UNASSEMBLED

THIS DRAWING IS A CONTROLLED DOCUMENT. DIMENSIONING AND TOLERANCING PER ASME Y14.5M-2009		DWN M. E. COWHER 09 JUN 2010	TE Connectivity	
DIMENSIONS: mm		CHK M. D. MORRISON 10 JUN 2010		
TOLERANCES UNLESS OTHERWISE SPECIFIED:		APVD M. D. MORRISON 10 JUN 2010	NAME RECEPTACLE ASSEMBLY WITH HEAT SINK, 84 POSITION, CXP	
0 PLC ±0.15 1 PLC ±0.15 2 PLC ±0.15 3 PLC ± 4 PLC ± ANGLES ± FINISH ±		PRODUCT SPEC 108-2426	RESTRICTED TO	
MATERIAL		APPLICATION SPEC 114-13283	SIZE A2	CAGE CODE 00779
1		WEIGHT -	DRAWING NO C-2149157	REV A
2		Customer Drawing	SCALE 1:1	SHEET 2 OF 5

THIS DRAWING IS UNPUBLISHED. RELEASED FOR PUBLICATION 20
 © COPYRIGHT 20 BY - ALL RIGHTS RESERVED.

REVISIONS				
P	LTR	DESCRIPTION	DATE	APVD
-		SEE SHEET 1	-	-

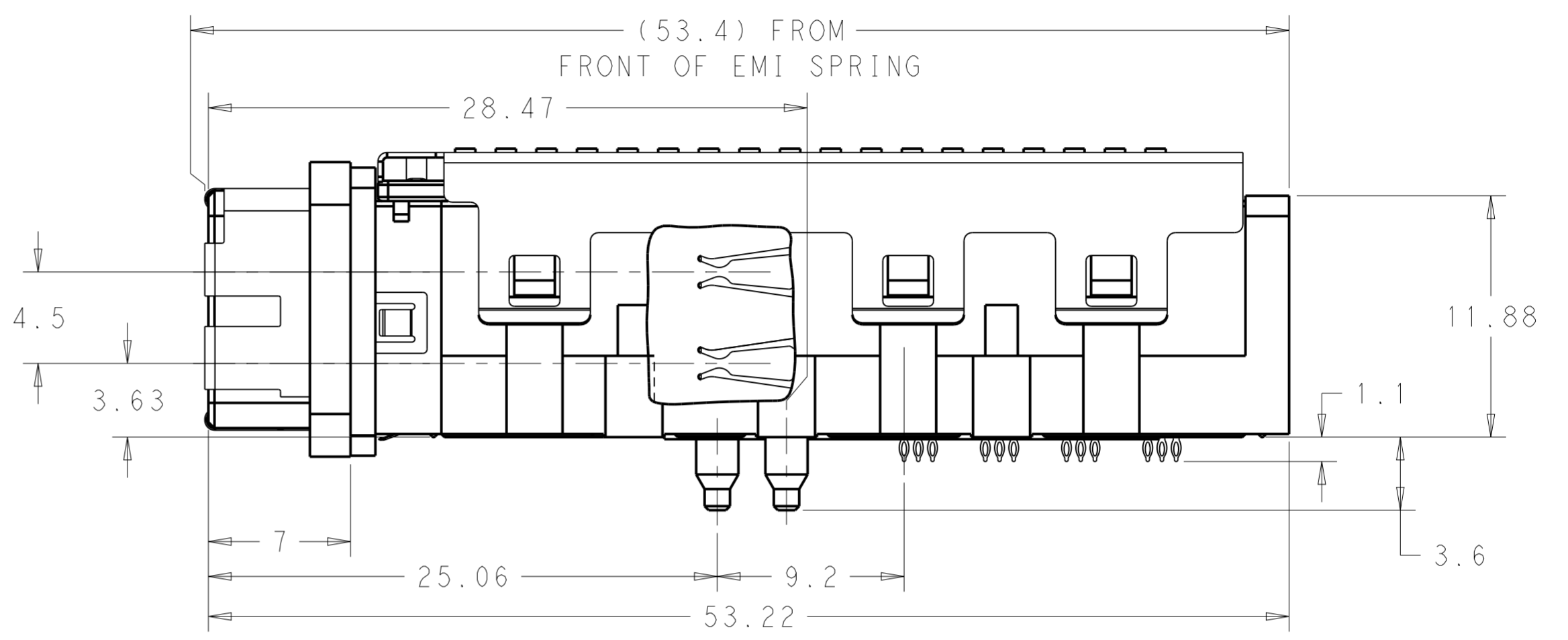
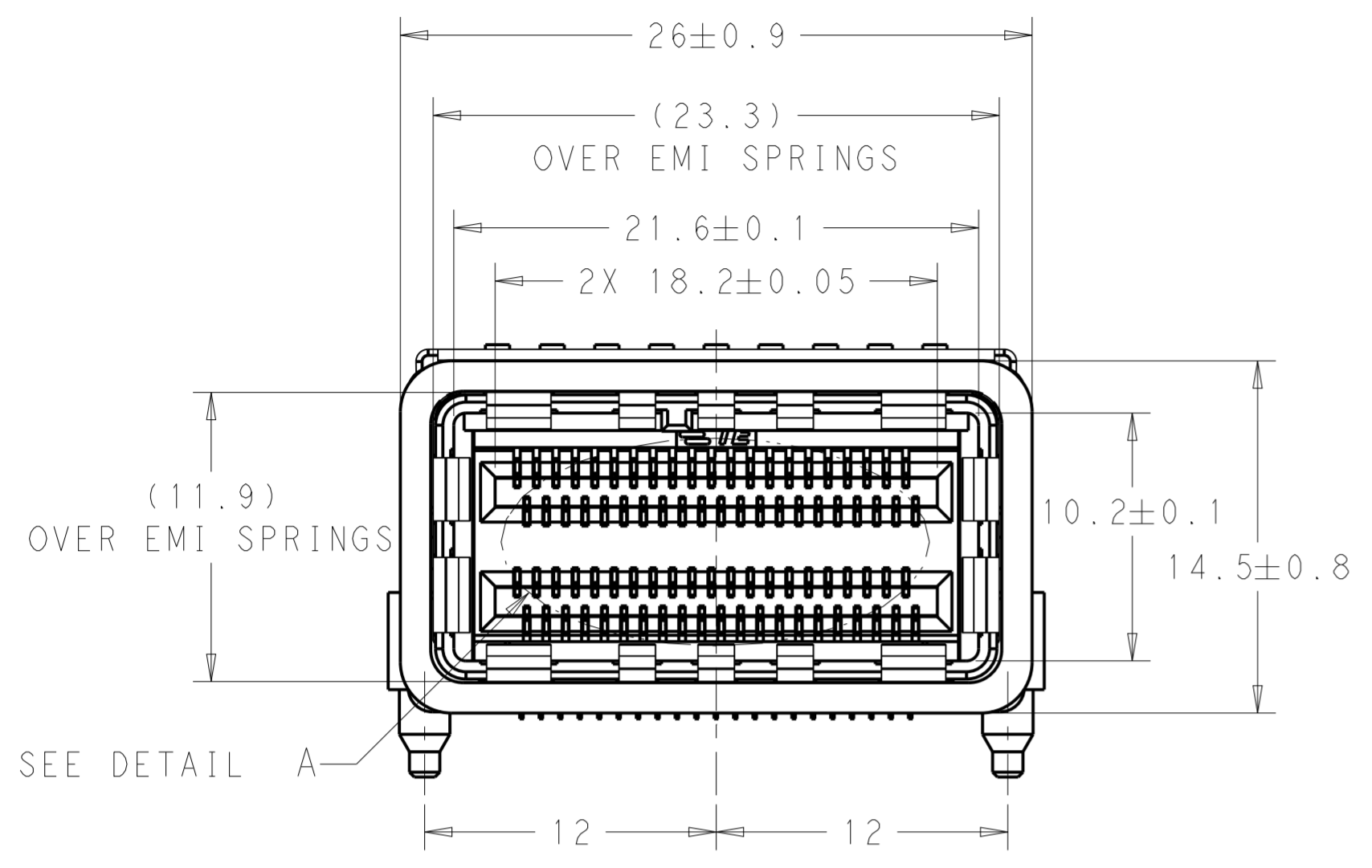

2149157-1
SCALE 4:1

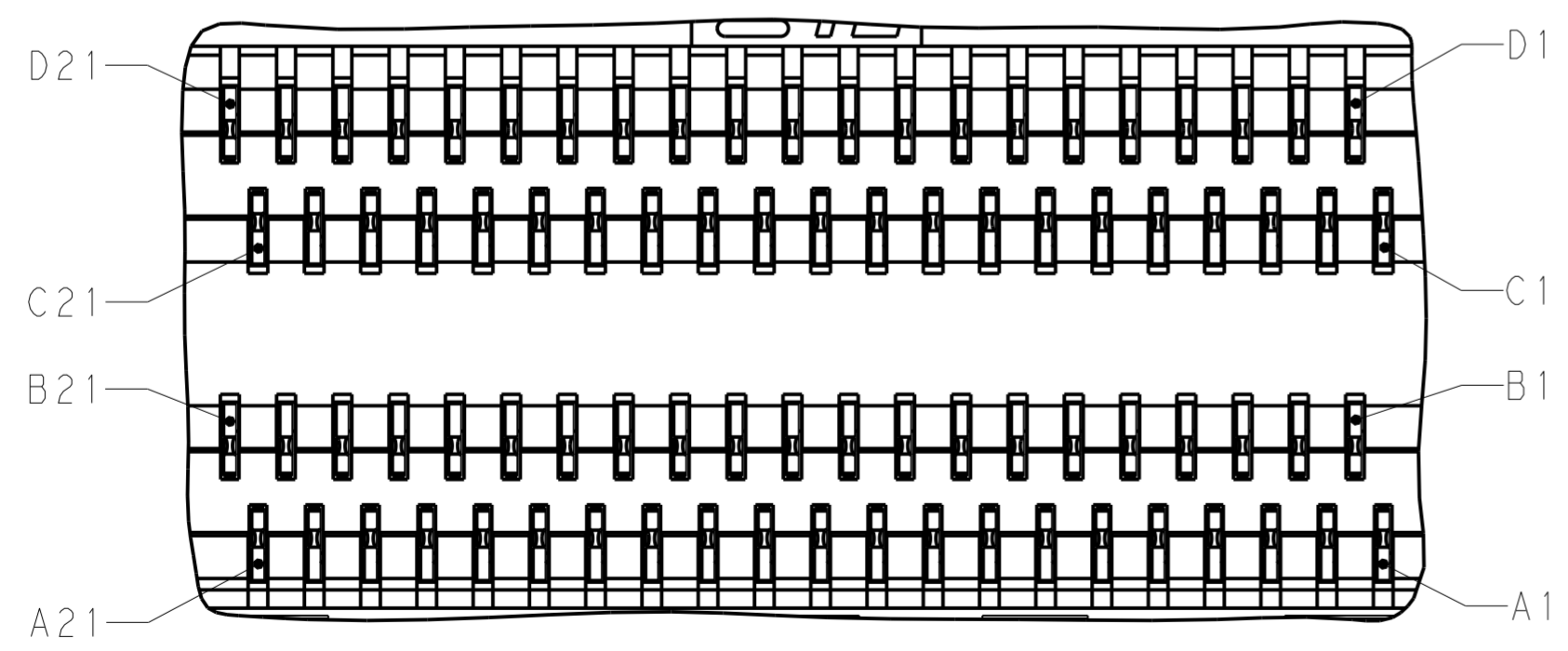

DETAIL A
CONNECTOR PIN CALLOUT
SCALE 10:1

THIS DRAWING IS A CONTROLLED DOCUMENT. DIMENSIONING AND TOLERANCING PER ASME Y14.5M-2009		DWN M.E. COWHER 09 JUN 2010 CHK M.D. MORRISON 10 JUN 2010 APVD M.D. MORRISON 10 JUN 2010	TE Connectivity NAME RECEPTACLE ASSEMBLY WITH HEAT SINK, 84 POSITION, CXP		
DIMENSIONS: mm	TOLERANCES UNLESS OTHERWISE SPECIFIED: 0 PLC ±0.15 1 PLC ±0.15 2 PLC ±0.15 3 PLC ± 4 PLC ± ANGLES ± FINISH ±	PRODUCT SPEC 108-2426 APPLICATION SPEC 114-13283 WEIGHT -			SIZE A200779 CAGE CODE C-2149157 DRAWING NO - RESTRICTED TO -
MATERIAL		Customer Drawing	SCALE 4:1	SHEET 3 OF 5	REV A

THIS DRAWING IS UNPUBLISHED. RELEASED FOR PUBLICATION 20
 © COPYRIGHT 20 BY - ALL RIGHTS RESERVED.

REVISIONS				
P	LTR	DESCRIPTION	DATE	APVD
-	-	SEE SHEET 1	-	-

6X $\varnothing 2.2 \pm 0.05$
 $\oplus \varnothing 0.1 \text{ (L) X Y}$
 PLATED THRU

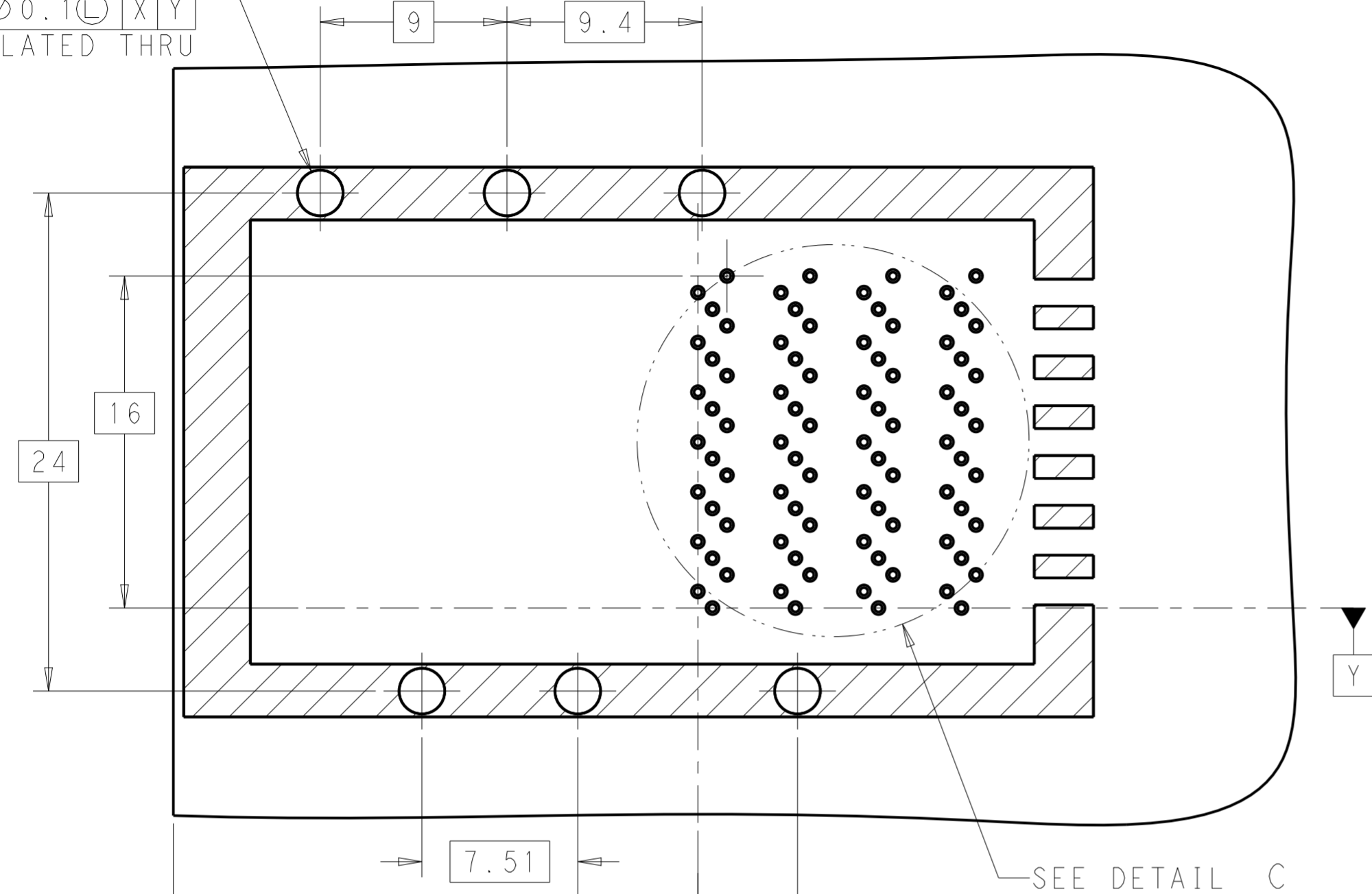

RECOMMENDED PCB LAYOUT
 COMPONENT SIDE SHOWN
 SCALE 4:1

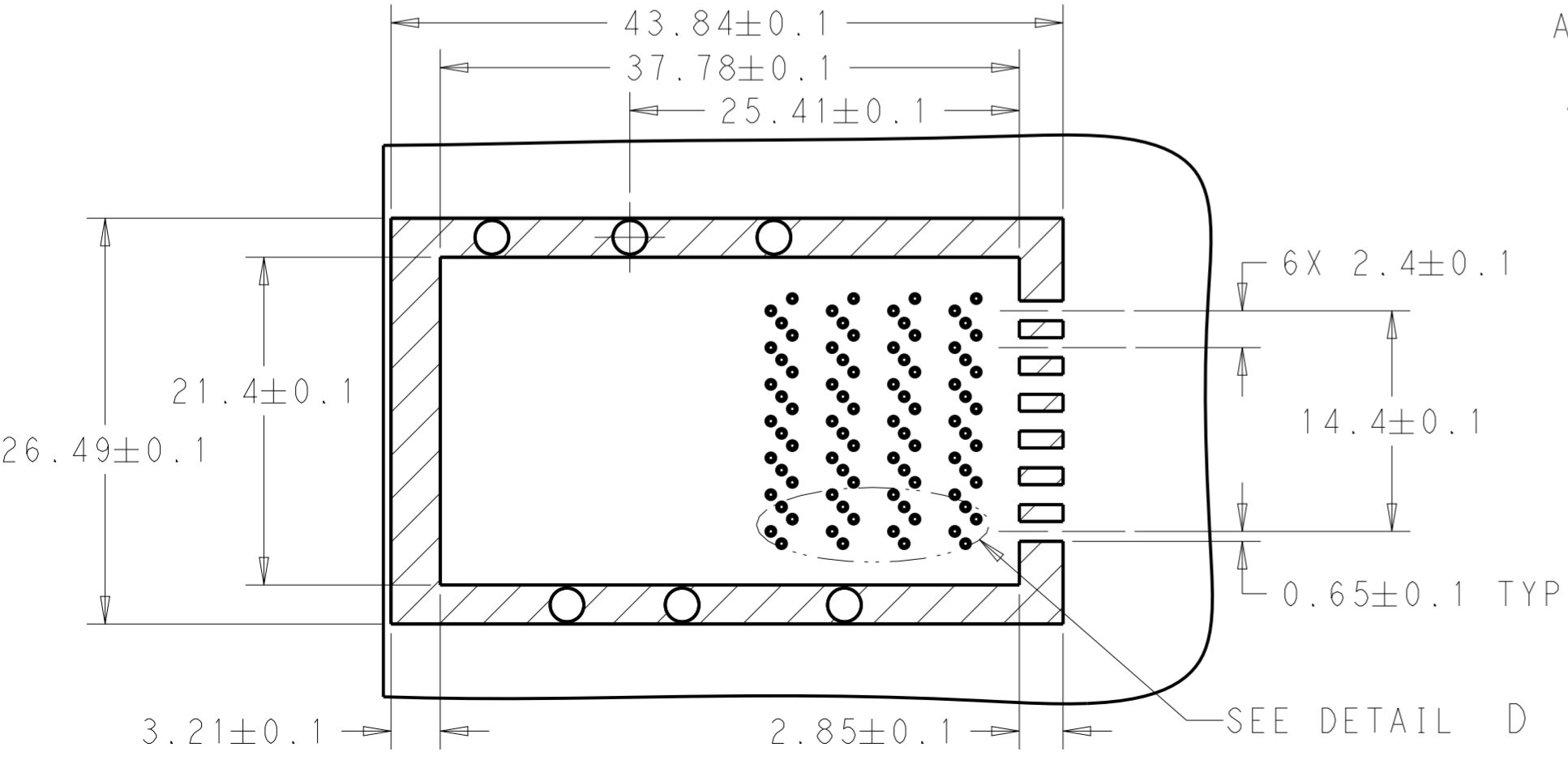

RECOMMENDED KEEPOUT AREA
 SCALE 5:2

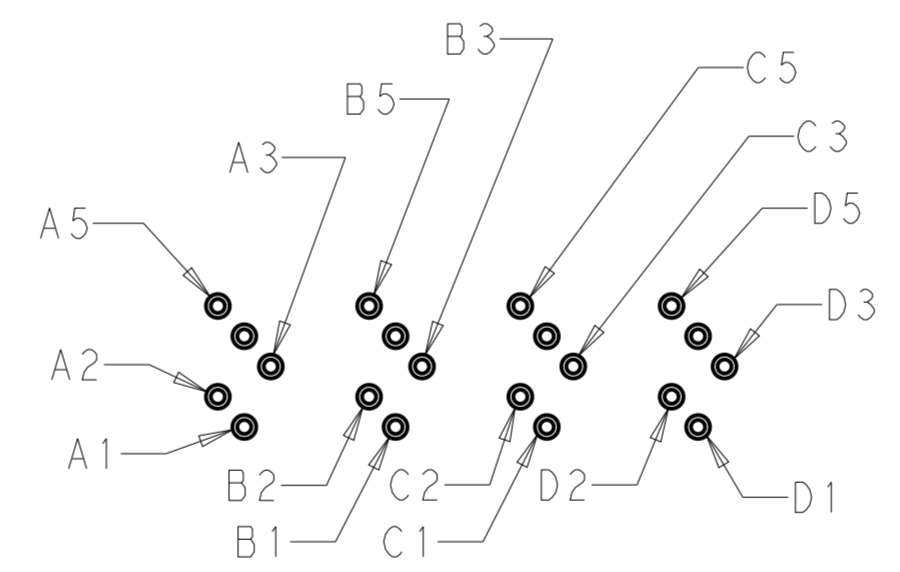

DETAIL D
 PIN CALLOUT (TYPICAL)
 SCALE 5:1

84X $\varnothing 0.37 \pm 0.05$
 $\oplus \varnothing 0.1 \text{ (L) X Y}$

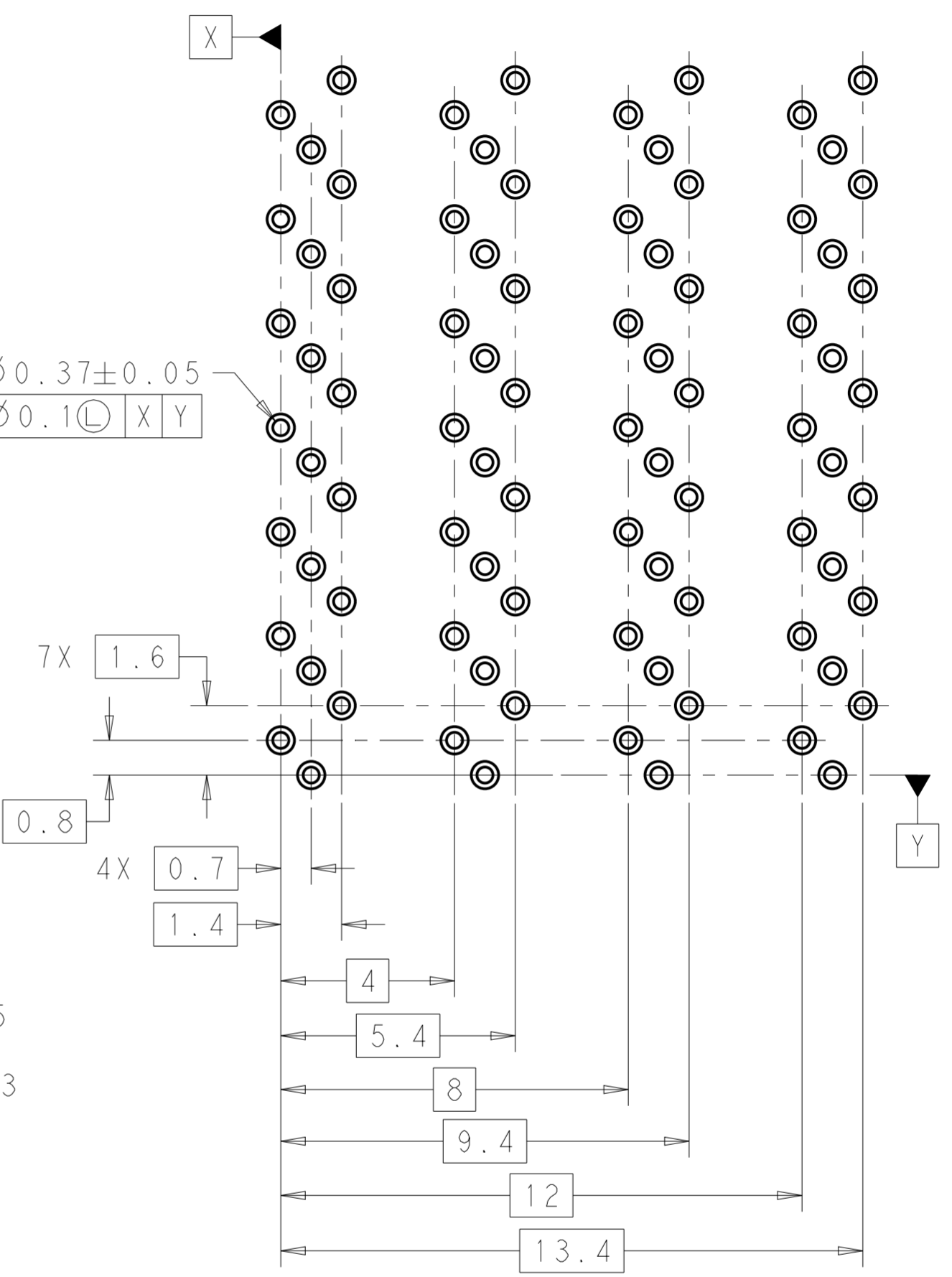

DETAIL C
 RECOMMENDED CONNECTOR LAYOUT
 SCALE 8:1

THIS DRAWING IS A CONTROLLED DOCUMENT. DIMENSIONING AND TOLERANCING PER ASME Y14.5M-2009		DWN M. E. COWHER 09 JUN 2010	TE Connectivity	
DIMENSIONS: mm		CHK M. D. MORRISON 10 JUN 2010		
TOLERANCES UNLESS OTHERWISE SPECIFIED:		APVD M. D. MORRISON 10 JUN 2010	NAME RECEPTACLE ASSEMBLY WITH HEAT SINK, 84 POSITION, CXP	
0 PLC ±0.15		PRODUCT SPEC 108-2426	SIZE CAGE CODE DRAWING NO RESTRICTED TO	
1 PLC ±0.15		APPLICATION SPEC 114-13283	A200779 C-2149157	
2 PLC ±0.15		WEIGHT	SCALE 3:1 SHEET 4 OF 5 REV A	
3 PLC ±		Customer Drawing		
4 PLC ±				
ANGLES ±				
FINISH ±				

THIS DRAWING IS UNPUBLISHED. RELEASED FOR PUBLICATION 20
 © COPYRIGHT 20 BY - ALL RIGHTS RESERVED.

REVISIONS				
P	LTR	DESCRIPTION	DATE	APVD
-		SEE SHEET 1	-	-

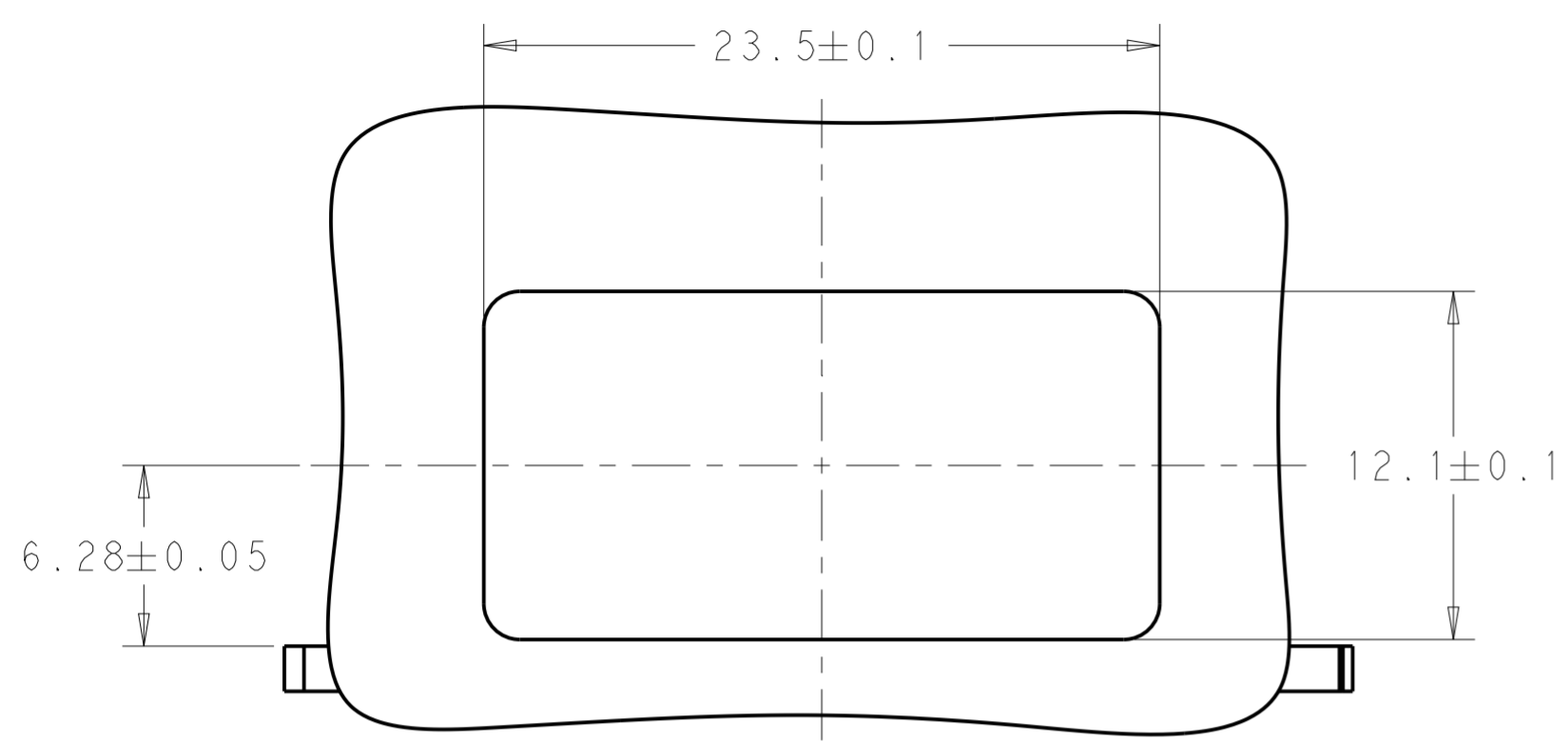

RECOMMENDED BRACKET CUT-OUT
SCALE 4:1

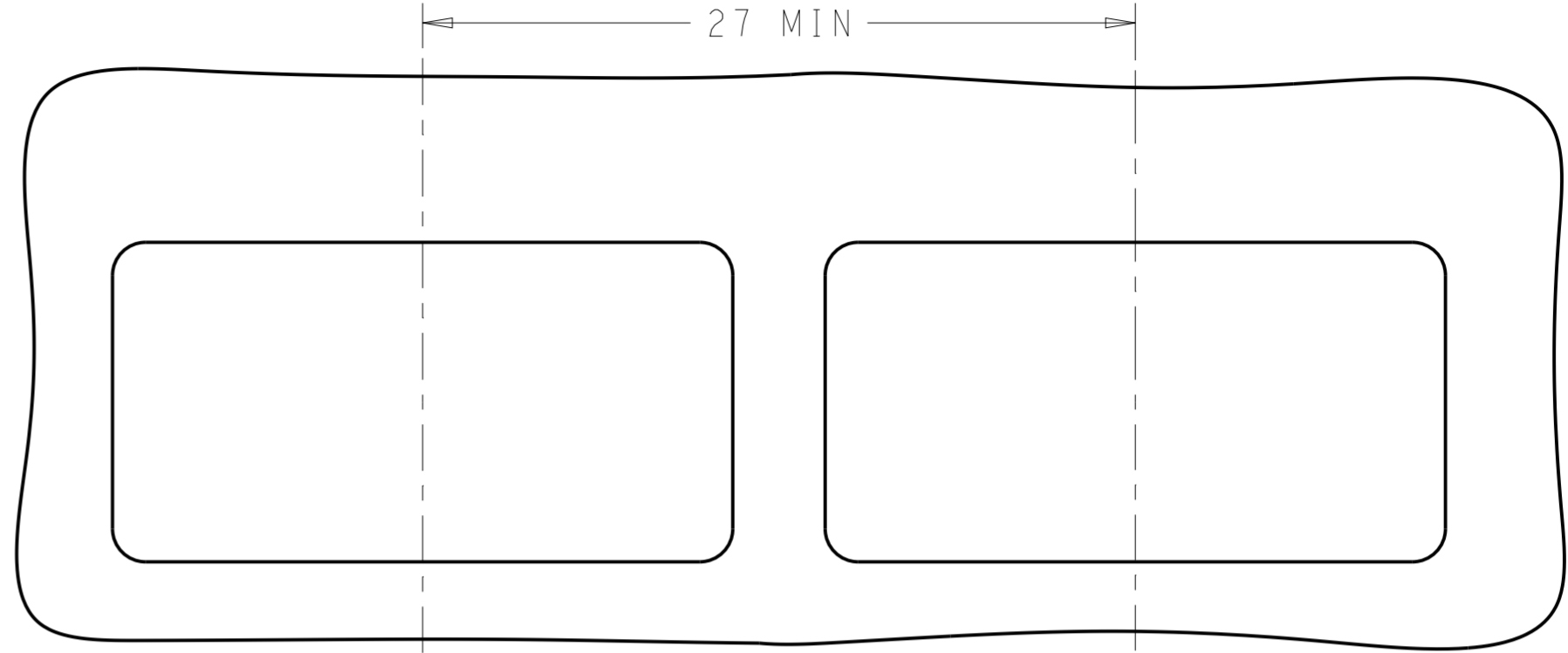

RECOMMENDED BRACKET CUT-OUT SPACING
SCALE 4:1

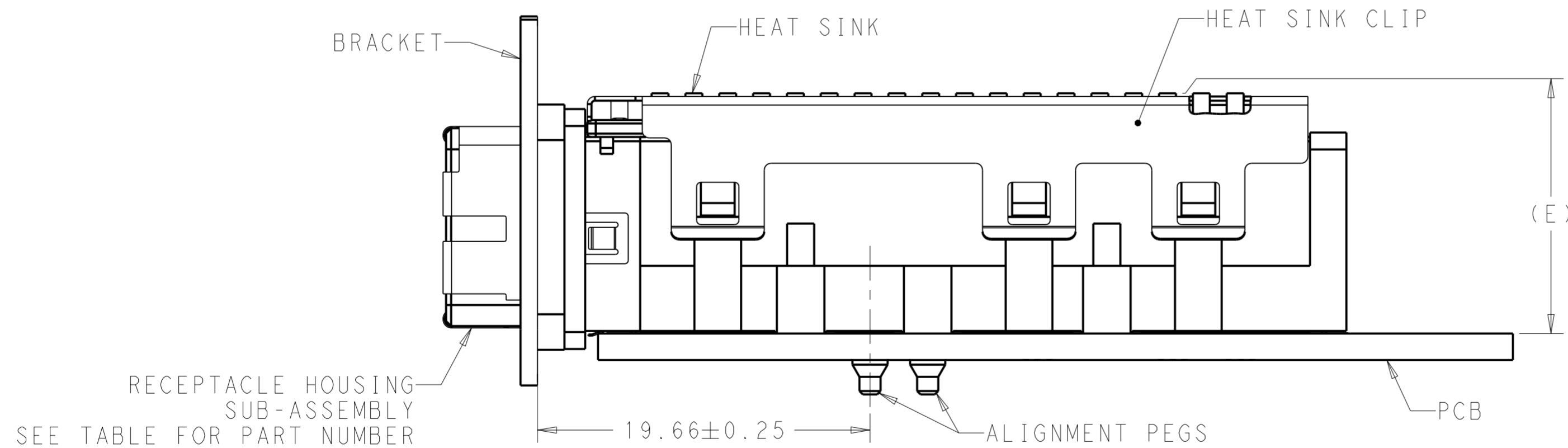

RECOMMEND BRACKET LOCATION AND
HEIGHT OF HEAT SINK MEASURED FROM PCB
SCALE 4:1

THIS DRAWING IS A CONTROLLED DOCUMENT. DIMENSIONING AND TOLERANCING PER ASME Y14.5M-2009		DWN 09 JUN 2010 M. E. COWHER	TE Connectivity	
DIMENSIONS: mm		CHK 10 JUN 2010 M. D. MORRISON		
TOLERANCES UNLESS OTHERWISE SPECIFIED:		APVD 10 JUN 2010 M. D. MORRISON	NAME RECEPTACLE ASSEMBLY WITH HEAT SINK, 84 POSITION, CXP	
0 PLC ±0.15	1 PLC ±0.15	PRODUCT SPEC 108-2426	SIZE	CAGE CODE
2 PLC ±0.15	3 PLC ±	APPLICATION SPEC 114-13283	A200779	DRAWING NO C-2149157
4 PLC ±	ANGLES ±	WEIGHT -	RESTRICTED TO	
MATERIAL FINISH		Customer Drawing	SCALE 4:1	SHEET 5 OF 5 REV A