

Customer Information Sheet

DRAWING No.: D3080-XX

SHEET 2 OF 2

IF IN DOUBT - ASK

©

NOT TO SCALE

THIRD ANGLE PROJECTION

ALL DIMENSIONS IN mm

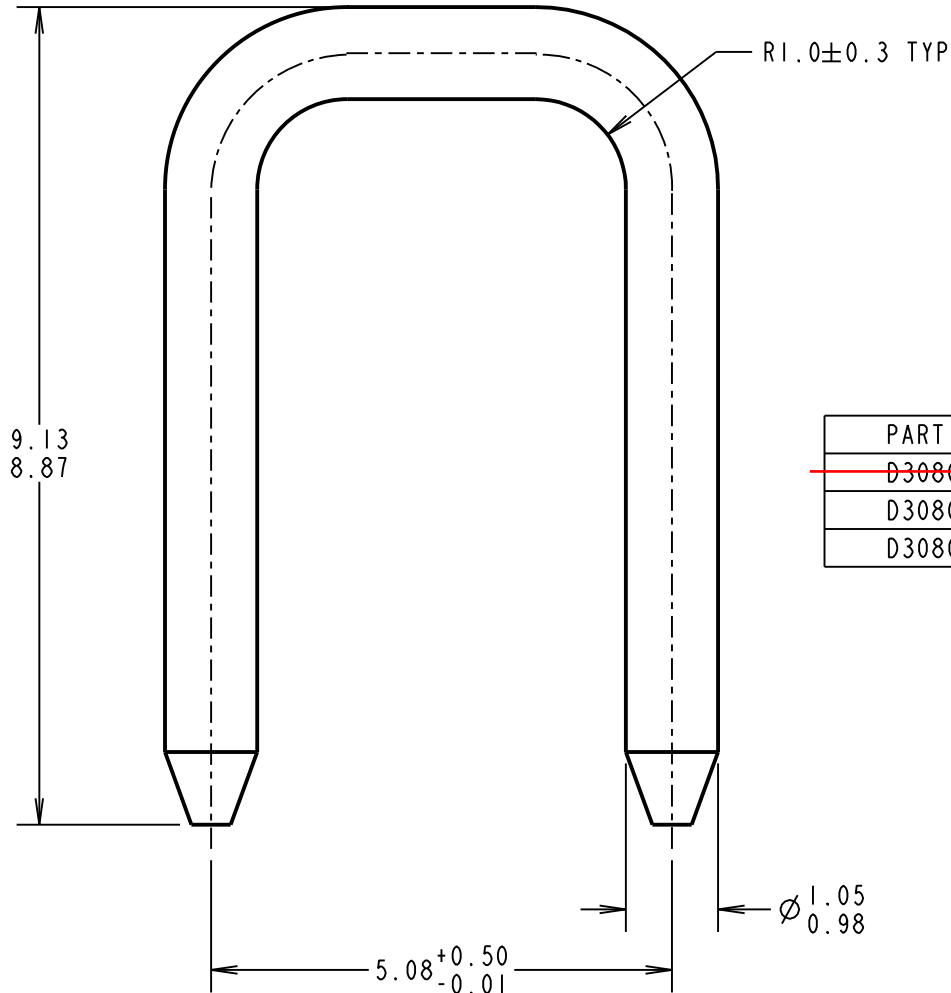

OBSOLETE

ORDER CODE:

D3080-XX

FINISH:

~~01 = 100% MATTE TIN~~
05 = GOLD FLASH
46 = 100% BRIGHT TIN

PART No.	FINISH
D3080-01	2.54μ 100% MATTE TIN OVER 0.76μ NICKEL UNDERCOAT
D3080-05	GOLD FLASH OVER 0.76 μ NICKEL UNDERCOAT
D3080-46	2.54 μ 100% BRIGHT TIN OVER 0.76 μ NICKEL UNDERCOAT

SB	12	18.12.12	11891
NAME	ISS.	DATE	C/NOTE
APPROVED:		S.BENNETT	
CHECKED:		S.FLOWER	
DRAWN:		C. HANSEN	
CUSTOMER REF.:			
ASSEMBLY DRG:			
D3086-XX			

HARWIN

www.harwin.com
technical@harwin.com

THIS DRAWING AND ANY INFORMATION OR DESCRIPTIVE MATTER SET OUT HEREON ARE CONFIDENTIAL AND COPYRIGHT PROPERTY OF THE HARWIN GROUP AND MUST NOT BE DISCLOSED, LOANED, COPIED OR USED FOR MANUFACTURING, TENDERING OR FOR ANY OTHER PURPOSE WITHOUT THEIR WRITTEN PERMISSION.

TOLERANCES

X. = ± 1 mm
X.X = ± 0.25 mm
X.XX = ± 0.10 mm
X.XXX = ± 0.01 mm

ANGLES = $\pm 5^\circ$

UNLESS STATED

MATERIAL:

BRASS C2600

FINISH: SEE ABOVE

S/AREA: mm²

TITLE:

1mm SHORTING LINK

DRAWING NUMBER:

D3080-XX

SHT
2
OF
2