

458139-1

1. APPLY PART NUMBER **458139**

PER PROCESS SPEC.
106-2 PARA. 3.3-A, B or C
IN AREA X

2. DIMENSIONS I & II TO BE EQUAL WITHIN .005

3. TOLERANCE APPLIES TO THIS SIDE ONLY.

4. DO NOT BREAK EDGES & CORNERS ON TOP SIDE OF ANVIL, REMOVE BURRS ONLY.

5. APPLY PROTECTIVE COATING PER MES-107-1025

USED ON

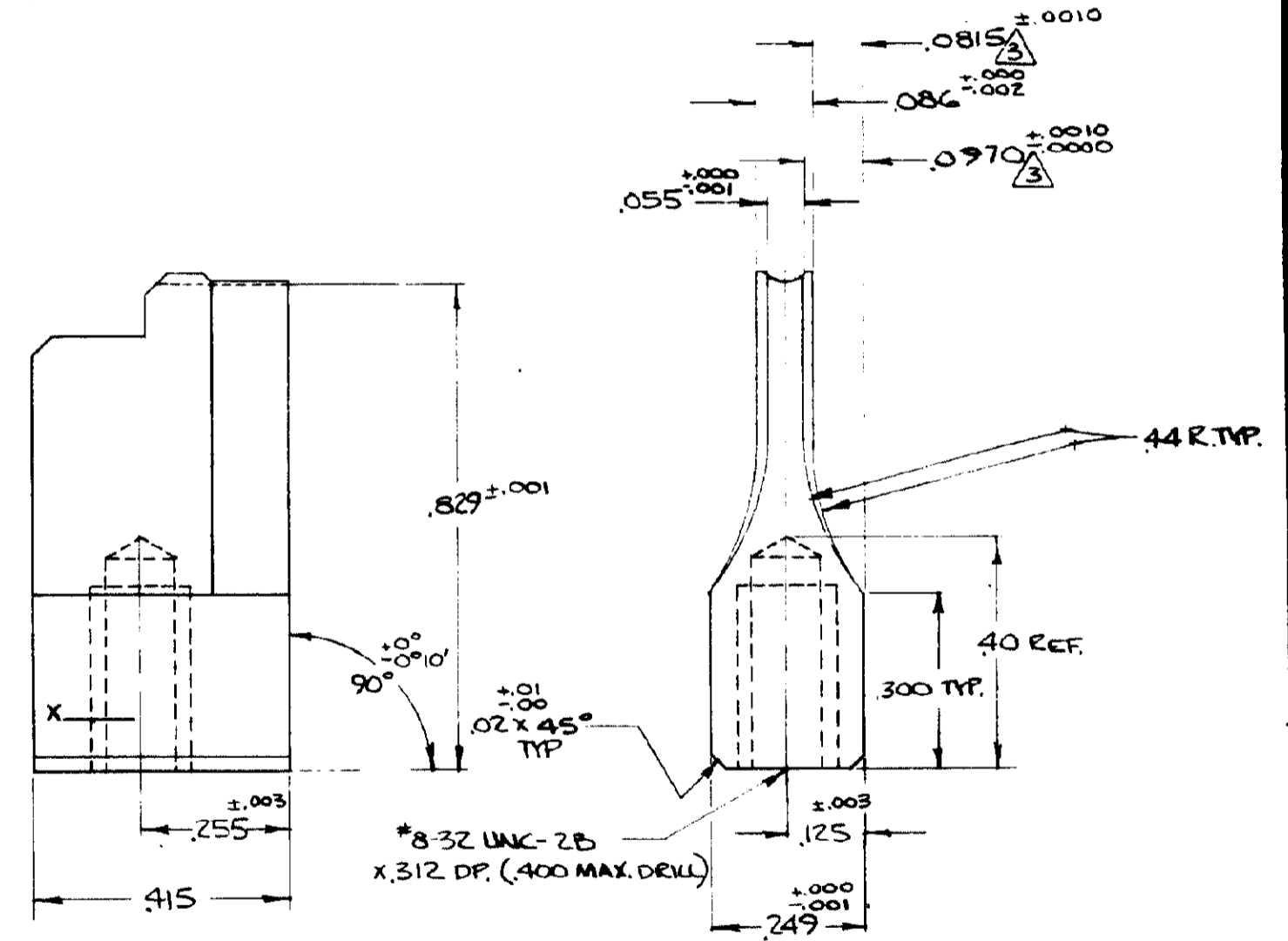
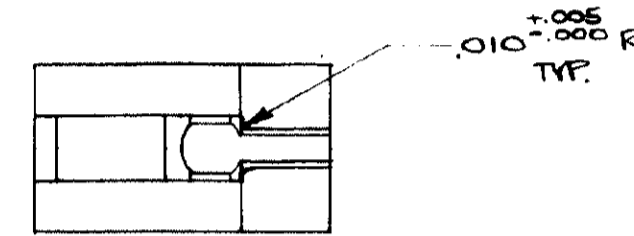
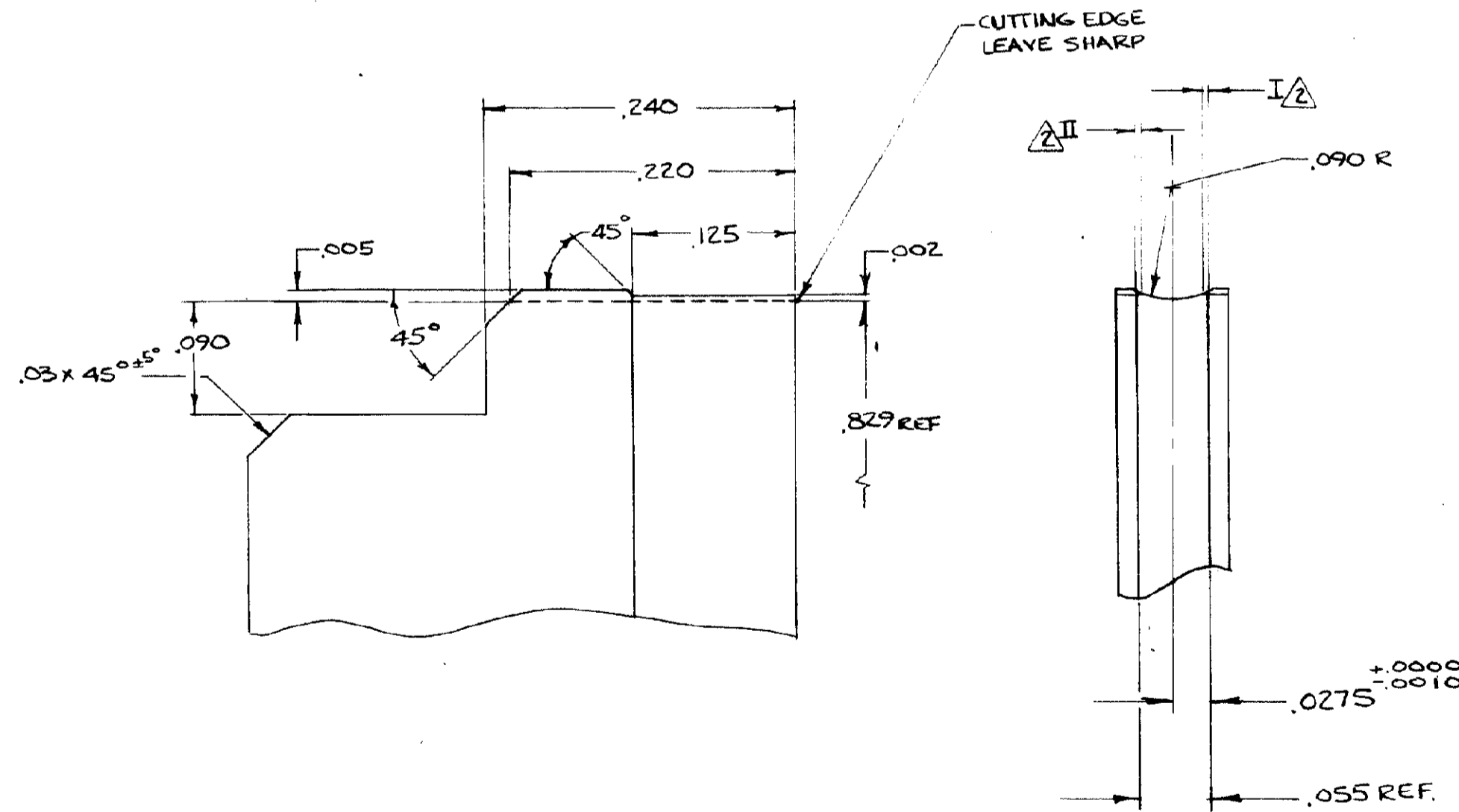

THIS INFORMATION IS CONFIDENTIAL AND IS DISCLOSED TO YOU ON THE CONDITION THAT NO FURTHER DISCLOSURE IS MADE BY YOU TO OTHERS THAN AMP PERSONNEL WITHOUT WRITTEN AUTHORIZATION FROM AMP TECHNOLOGICAL, HARRISBURG, PA.
DIMENSIONS IN INCHES. DO NOT SCALE PRINT.

UNLESS OTHERWISE SPECIFIED		REMOVE BURRS, BREAK SHARP EDGES .015 R MAX		32J
DECIMALS: .50 = 2.0Z, .000 = 2.00Z, .0000 = 2.000Z		ANGLES: 30°		
MATERIAL	100-43	DR	12-20-72	APP
HEAT TREAT	111-43-5.3 R 56-58	ENR	12-26-72	REL
COATING OR PLATING	112-157	CHK	12-26-72	REL
PERSONNEL FIRST USED	62129	NAME	ANVIL, SPECIAL	
TYPE	LW	DATE	4-7	