

MPU-9250

Product Specification

Revision 1.1

CONTENTS

1	DOCUMENT INFORMATION	4
1.1	REVISION HISTORY	4
1.2	PURPOSE AND SCOPE.....	5
1.3	PRODUCT OVERVIEW	5
1.4	APPLICATIONS	5
2	FEATURES	6
2.1	GYROSCOPE FEATURES.....	6
2.2	ACCELEROMETER FEATURES	6
2.3	MAGNETOMETER FEATURES.....	6
2.4	ADDITIONAL FEATURES	6
2.5	MOTIONPROCESSING.....	7
3	ELECTRICAL CHARACTERISTICS	8
3.1	GYROSCOPE SPECIFICATIONS	8
3.2	ACCELEROMETER SPECIFICATIONS.....	9
3.3	MAGNETOMETER SPECIFICATIONS.....	10
3.4	ELECTRICAL SPECIFICATIONS.....	11
3.5	I2C TIMING CHARACTERIZATION.....	15
3.6	SPI TIMING CHARACTERIZATION.....	16
3.7	ABSOLUTE MAXIMUM RATINGS	18
4	APPLICATIONS INFORMATION	19
4.1	PIN OUT AND SIGNAL DESCRIPTION.....	19
4.2	TYPICAL OPERATING CIRCUIT.....	20
4.3	BILL OF MATERIALS FOR EXTERNAL COMPONENTS	20
4.4	BLOCK DIAGRAM	21
4.5	OVERVIEW	22
4.6	THREE-AXIS MEMS GYROSCOPE WITH 16-BIT ADCs AND SIGNAL CONDITIONING.....	22
4.7	THREE-AXIS MEMS ACCELEROMETER WITH 16-BIT ADCs AND SIGNAL CONDITIONING	22
4.8	THREE-AXIS MEMS MAGNETOMETER WITH 16-BIT ADCs AND SIGNAL CONDITIONING	22
4.9	DIGITAL MOTION PROCESSOR	22
4.10	PRIMARY I2C AND SPI SERIAL COMMUNICATIONS INTERFACES.....	23
4.11	AUXILIARY I2C SERIAL INTERFACE.....	23
4.12	SELF-TEST	24
4.13	MPU-9250 SOLUTION USING I2C INTERFACE.....	25

4.14	MPU-9250 SOLUTION USING SPI INTERFACE.....	26
4.15	CLOCKING.....	26
4.16	SENSOR DATA REGISTERS.....	27
4.17	FIFO.....	27
4.18	INTERRUPTS.....	27
4.19	DIGITAL-OUTPUT TEMPERATURE SENSOR.....	27
4.20	BIAS AND LDO.....	28
4.21	CHARGE PUMP.....	28
4.22	STANDARD POWER MODE.....	28
4.23	POWER SEQUENCING REQUIREMENTS AND POWER ON RESET.....	28
5	ADVANCED HARDWARE FEATURES.....	29
6	PROGRAMMABLE INTERRUPTS.....	30
6.1	WAKE-ON-MOTION INTERRUPT.....	30
7	DIGITAL INTERFACE.....	32
7.1	I2C AND SPI SERIAL INTERFACES.....	32
7.2	I2C INTERFACE.....	32
7.3	I2C COMMUNICATIONS PROTOCOL.....	32
7.4	I2C TERMS.....	35
7.5	SPI INTERFACE.....	36
8	SERIAL INTERFACE CONSIDERATIONS.....	37
8.1	MPU-9250 SUPPORTED INTERFACES.....	37
9	ASSEMBLY.....	38
9.1	ORIENTATION OF AXES.....	38
9.2	PACKAGE DIMENSIONS.....	38
10	PART NUMBER PACKAGE MARKING.....	40
11	RELIABILITY.....	41
11.1	QUALIFICATION TEST POLICY.....	41
11.2	QUALIFICATION TEST PLAN.....	41
12	REFERENCE.....	42

1 Document Information

1.1 Revision History

Revision Date	Revision	Description
12/18/13	1.0	Initial Release
06/20/16	1.1	Updated Section 4

1.2 Purpose and Scope

This document provides a description, specifications, and design related information on the MPU-9250 MotionTracking device. The device is housed in a small 3x3x1mm QFN package.

Specifications are subject to change without notice. Final specifications will be updated based upon characterization of production silicon. For references to register map and descriptions of individual registers, please refer to the MPU-9250 Register Map and Register Descriptions document.

1.3 Product Overview

MPU-9250 is a multi-chip module (MCM) consisting of two dies integrated into a single QFN package. One die houses the 3-Axis gyroscope and the 3-Axis accelerometer. The other die houses the AK8963 3-Axis magnetometer from Asahi Kasei Microdevices Corporation. Hence, the MPU-9250 is a 9-axis MotionTracking device that combines a 3-axis gyroscope, 3-axis accelerometer, 3-axis magnetometer and a Digital Motion Processor™ (DMP) all in a small 3x3x1mm package available as a pin-compatible upgrade from the MPU-6515. With its dedicated I²C sensor bus, the MPU-9250 directly provides complete 9-axis MotionFusion™ output. The MPU-9250 MotionTracking device, with its 9-axis integration, on-chip MotionFusion™, and run-time calibration firmware, enables manufacturers to eliminate the costly and complex selection, qualification, and system level integration of discrete devices, guaranteeing optimal motion performance for consumers. MPU-9250 is also designed to interface with multiple non-inertial digital sensors, such as pressure sensors, on its auxiliary I²C port.

MPU-9250 features three 16-bit analog-to-digital converters (ADCs) for digitizing the gyroscope outputs, three 16-bit ADCs for digitizing the accelerometer outputs, and three 16-bit ADCs for digitizing the magnetometer outputs. For precision tracking of both fast and slow motions, the parts feature a user-programmable gyroscope full-scale range of ± 250 , ± 500 , ± 1000 , and $\pm 2000^\circ/\text{sec}$ (dps), a user-programmable accelerometer full-scale range of $\pm 2g$, $\pm 4g$, $\pm 8g$, and $\pm 16g$, and a magnetometer full-scale range of $\pm 4800\mu\text{T}$.

Other industry-leading features include programmable digital filters, a precision clock with 1% drift from -40°C to 85°C , an embedded temperature sensor, and programmable interrupts. The device features I²C and SPI serial interfaces, a VDD operating range of 2.4V to 3.6V, and a separate digital IO supply, VDDIO from 1.71V to VDD.

Communication with all registers of the device is performed using either I²C at 400kHz or SPI at 1MHz. For applications requiring faster communications, the sensor and interrupt registers may be read using SPI at 20MHz.

By leveraging its patented and volume-proven CMOS-MEMS fabrication platform, which integrates MEMS wafers with companion CMOS electronics through wafer-level bonding, InvenSense has driven the package size down to a footprint and thickness of 3x3x1mm, to provide a very small yet high performance low cost package. The device provides high robustness by supporting 10,000g shock reliability.

1.4 Applications

- Location based services, points of interest, and dead reckoning
- Handset and portable gaming
- Motion-based game controllers
- 3D remote controls for Internet connected DTVs and set top boxes, 3D mice
- Wearable sensors for health, fitness and sports

2 Features

2.1 Gyroscope Features

The triple-axis MEMS gyroscope in the MPU-9250 includes a wide range of features:

- Digital-output X-, Y-, and Z-Axis angular rate sensors (gyroscopes) with a user-programmable full-scale range of ± 250 , ± 500 , ± 1000 , and $\pm 2000^\circ/\text{sec}$ and integrated 16-bit ADCs
- Digitally-programmable low-pass filter
- Gyroscope operating current: 3.2mA
- Sleep mode current: $8\mu\text{A}$
- Factory calibrated sensitivity scale factor
- Self-test

2.2 Accelerometer Features

The triple-axis MEMS accelerometer in MPU-9250 includes a wide range of features:

- Digital-output triple-axis accelerometer with a programmable full scale range of $\pm 2g$, $\pm 4g$, $\pm 8g$ and $\pm 16g$ and integrated 16-bit ADCs
- Accelerometer normal operating current: $450\mu\text{A}$
- Low power accelerometer mode current: $8.4\mu\text{A}$ at 0.98Hz, $19.8\mu\text{A}$ at 31.25Hz
- Sleep mode current: $8\mu\text{A}$
- User-programmable interrupts
- Wake-on-motion interrupt for low power operation of applications processor
- Self-test

2.3 Magnetometer Features

The triple-axis MEMS magnetometer in MPU-9250 includes a wide range of features:

- 3-axis silicon monolithic Hall-effect magnetic sensor with magnetic concentrator
- Wide dynamic measurement range and high resolution with lower current consumption.
- Output data resolution of 14 bit ($0.6\mu\text{T}/\text{LSB}$)
- Full scale measurement range is $\pm 4800\mu\text{T}$
- Magnetometer normal operating current: $280\mu\text{A}$ at 8Hz repetition rate
- Self-test function with internal magnetic source to confirm magnetic sensor operation on end products

2.4 Additional Features

The MPU-9250 includes the following additional features:

- Auxiliary master I²C bus for reading data from external sensors (e.g. pressure sensor)
- 3.5mA operating current when all 9 motion sensing axes and the DMP are enabled
- VDD supply voltage range of 2.4 – 3.6V
- VDDIO reference voltage for auxiliary I²C devices
- Smallest and thinnest QFN package for portable devices: 3x3x1mm
- Minimal cross-axis sensitivity between the accelerometer, gyroscope and magnetometer axes
- 512 byte FIFO buffer enables the applications processor to read the data in bursts
- Digital-output temperature sensor
- User-programmable digital filters for gyroscope, accelerometer, and temp sensor
- 10,000 g shock tolerant
- 400kHz Fast Mode I²C for communicating with all registers
- 1MHz SPI serial interface for communicating with all registers

- 20MHz SPI serial interface for reading sensor and interrupt registers
- MEMS structure hermetically sealed and bonded at wafer level
- RoHS and Green compliant

2.5 MotionProcessing

- Internal Digital Motion Processing™ (DMP™) engine supports advanced MotionProcessing and low power functions such as gesture recognition using programmable interrupts
- Low-power pedometer functionality allows the host processor to sleep while the DMP maintains the step count.

3 Electrical Characteristics

3.1 Gyroscope Specifications

Typical Operating Circuit of section [4.2](#), VDD = 2.5V, VDDIO = 2.5V, T_A=25°C, unless otherwise noted.

PARAMETER	CONDITIONS	MIN	TYP	MAX	UNITS
Full-Scale Range	FS_SEL=0		±250		°/s
	FS_SEL=1		±500		°/s
	FS_SEL=2		±1000		°/s
	FS_SEL=3		±2000		°/s
Gyroscope ADC Word Length			16		bits
Sensitivity Scale Factor	FS_SEL=0		131		LSB/(°/s)
	FS_SEL=1		65.5		LSB/(°/s)
	FS_SEL=2		32.8		LSB/(°/s)
	FS_SEL=3		16.4		LSB/(°/s)
Sensitivity Scale Factor Tolerance	25°C		±3		%
Sensitivity Scale Factor Variation Over Temperature	-40°C to +85°C		±4		%
Nonlinearity	Best fit straight line; 25°C		±0.1		%
Cross-Axis Sensitivity			±2		%
Initial ZRO Tolerance	25°C		±5		°/s
ZRO Variation Over Temperature	-40°C to +85°C		±30		°/s
Total RMS Noise	DLPFCFG=2 (92 Hz)		0.1		°/s-rms
Rate Noise Spectral Density			0.01		°/s/√Hz
Gyroscope Mechanical Frequencies		25	27	29	KHz
Low Pass Filter Response	Programmable Range	5		250	Hz
Gyroscope Startup Time	From Sleep mode		35		ms
Output Data Rate	Programmable, Normal mode	4		8000	Hz

Table 1 Gyroscope Specifications

3.2 Accelerometer Specifications

Typical Operating Circuit of section 4.2, VDD = 2.5V, VDDIO = 2.5V, T_A=25°C, unless otherwise noted.

PARAMETER	CONDITIONS	MIN	TYP	MAX	UNITS
Full-Scale Range	AFS_SEL=0		±2		g
	AFS_SEL=1		±4		g
	AFS_SEL=2		±8		g
	AFS_SEL=3		±16		g
ADC Word Length	Output in two's complement format		16		bits
Sensitivity Scale Factor	AFS_SEL=0		16,384		LSB/g
	AFS_SEL=1		8,192		LSB/g
	AFS_SEL=2		4,096		LSB/g
	AFS_SEL=3		2,048		LSB/g
Initial Tolerance	Component-Level		±3		%
Sensitivity Change vs. Temperature	-40°C to +85°C AFS_SEL=0 Component-level		±0.026		%/°C
Nonlinearity	Best Fit Straight Line		±0.5		%
Cross-Axis Sensitivity			±2		%
Zero-G Initial Calibration Tolerance	Component-level, X,Y		±60		mg
	Component-level, Z		±80		mg
Zero-G Level Change vs. Temperature	-40°C to +85°C		±1.5		mg/°C
Noise Power Spectral Density	Low noise mode		300		µg/√Hz
Total RMS Noise	DLPCFG=2 (94Hz)			8	mg-rms
Low Pass Filter Response	Programmable Range	5		260	Hz
Intelligence Function Increment			4		mg/LSB
Accelerometer Startup Time	From Sleep mode		20		ms
	From Cold Start, 1ms V _{DD} ramp		30		ms
Output Data Rate	Low power (duty-cycled)	0.24		500	Hz
	Duty-cycled, over temp		±15		%
	Low noise (active)	4		4000	Hz

Table 2 Accelerometer Specifications

3.3 Magnetometer Specifications

Typical Operating Circuit of section [4.2](#), VDD = 2.5V, VDDIO = 2.5V, T_A=25°C, unless otherwise noted.

PARAMETER	CONDITIONS	MIN	TYP	MAX	UNITS
MAGNETOMETER SENSITIVITY					
Full-Scale Range			±4800		μT
ADC Word Length			14		bits
Sensitivity Scale Factor			0.6		μT / LSB
ZERO-FIELD OUTPUT					
Initial Calibration Tolerance			±500		LSB

3.4 Electrical Specifications

3.4.1 D.C. Electrical Characteristics

Typical Operating Circuit of section 4.2, VDD = 2.5V, VDDIO = 2.5V, T_A=25°C, unless otherwise noted.

PARAMETER	CONDITIONS	MIN	TYP	MAX	Units	Notes
SUPPLY VOLTAGES						
VDD		2.4	2.5	3.6	V	
VDDIO		1.71	1.8	VDD	V	
SUPPLY CURRENTS						
Normal Mode	9-axis (no DMP), 1 kHz gyro ODR, 4 kHz accel ODR, 8 Hz mag. repetition rate		3.7		mA	
	6-axis (accel + gyro, no DMP), 1 kHz gyro ODR, 4 kHz accel ODR		3.4		mA	
	3-axis Gyroscope only (no DMP), 1 kHz ODR		3.2		mA	
	6-axis (accel + magnetometer, no DMP), 4 kHz accel ODR, mag. repetition rate = 8 Hz		730		μA	
	3-Axis Accelerometer, 4kHz ODR (no DMP)		450		μA	
	3-axis Magnetometer only (no DMP), 8 Hz repetition rate		280		μA	
Accelerometer Low Power Mode (DMP, Gyroscope, Magnetometer disabled)	0.98 Hz update rate		8.4		μA	1
	31.25 Hz update rate		19.8		μA	1
Full Chip Idle Mode Supply Current			8		μA	
TEMPERATURE RANGE						
Specified Temperature Range	Performance parameters are not applicable beyond Specified Temperature Range	-40		+85	°C	

Table 3 D.C. Electrical Characteristics

Notes:

1. Accelerometer Low Power Mode supports the following output data rates (ODRs): 0.24, 0.49, 0.98, 1.95, 3.91, 7.81, 15.63, 31.25, 62.50, 125, 250, 500Hz. Supply current for any update rate can be calculated as:

$$\text{Supply Current in } \mu\text{A} = \text{Sleep Current} + \text{Update Rate} * 0.376$$

3.4.2 A.C. Electrical Characteristics

Typical Operating Circuit of section 4.2, VDD = 2.5V, VDDIO = 2.5V, T_A=25°C, unless otherwise noted.

Parameter	Conditions	MIN	TYP	MAX	Units
Supply Ramp Time	Monotonic ramp. Ramp rate is 10% to 90% of the final value	0.1		100	ms
Operating Range	Ambient	-40		85	°C
Sensitivity	Untrimmed		333.87		LSB/°C
Room Temp Offset	21°C		0		LSB
Supply Ramp Time (T _{RAMP})	Valid power-on RESET	0.01	20	100	ms
Start-up time for register read/write	From power-up		11	100	ms
I²C ADDRESS	AD0 = 0 AD0 = 1		1101000 1101001		
V _{IH} , High Level Input Voltage		0.7*VDDIO			V
V _{IL} , Low Level Input Voltage				0.3*VDDIO	V
C _I , Input Capacitance			< 10		pF
V _{OH} , High Level Output Voltage	R _{LOAD} =1MΩ;	0.9*VDDIO			V
V _{OL1} , LOW-Level Output Voltage	R _{LOAD} =1MΩ;			0.1*VDDIO	V
V _{OLINT1} , INT Low-Level Output Voltage	OPEN=1, 0.3mA sink Current			0.1	V
Output Leakage Current	OPEN=1		100		nA
t _{INT} , INT Pulse Width	LATCH_INT_EN=0		50		μs
V _{IL} , LOW Level Input Voltage		-0.5V		0.3*VDDIO	V
V _{IH} , HIGH-Level Input Voltage		0.7*VDDIO		VDDIO + 0.5V	V
V _{hys} , Hysteresis			0.1*VDDIO		V
V _{OL} , LOW-Level Output Voltage	3mA sink current	0		0.4	V
I _{OL} , LOW-Level Output Current	V _{OL} =0.4V V _{OL} =0.6V		3 6		mA mA
Output Leakage Current			100		nA
t _{of} , Output Fall Time from V _{IHmax} to V _{ILmax}	C _b bus capacitance in pf	20+0.1C _b		250	ns
V _{IL} , LOW-Level Input Voltage		-0.5V		0.3*VDDIO	V
V _{IH} , HIGH-Level Input Voltage		0.7* VDDIO		VDDIO + 0.5V	V
V _{hys} , Hysteresis			0.1* VDDIO		V
V _{OL1} , LOW-Level Output Voltage	VDDIO > 2V; 1mA sink current	0		0.4	V
V _{OL3} , LOW-Level Output Voltage	VDDIO < 2V; 1mA sink current	0		0.2* VDDIO	V
I _{OL} , LOW-Level Output Current	V _{OL} = 0.4V V _{OL} = 0.6V		3 6		mA mA
Output Leakage Current			100		nA
t _{of} , Output Fall Time from V _{IHmax} to V _{ILmax}	C _b bus capacitance in pF	20+0.1C _b		250	ns
Sample Rate	Fchoice=0,1,2 SMPLRT_DIV=0		32		kHz
	Fchoice=3; DLPFCFG=0 or 7 SMPLRT_DIV=0		8		kHz
	Fchoice=3; DLPFCFG=1,2,3,4,5,6; SMPLRT_DIV=0		1		kHz
Clock Frequency Initial Tolerance	CLK_SEL=0, 6; 25°C	-2		+2	%

	CLK_SEL=1,2,3,4,5; 25°C	-1		+1	%
Frequency Variation over Temperature	CLK_SEL=0,6	-10		+10	%
	CLK_SEL=1,2,3,4,5		±1		%

Table 4 A.C. Electrical Characteristics

3.4.3 Other Electrical Specifications

Typical Operating Circuit of section [4.2](#), VDD = 2.5V, VDDIO = 2.5V, T_A=25°C, unless otherwise noted.

PARAMETER	CONDITIONS	MIN	TYP	MAX	Units
SPI Operating Frequency, All Registers Read/Write	Low Speed Characterization		100 ±10%		kHz
	High Speed Characterization		1 ±10%		MHz
SPI Operating Frequency, Sensor and Interrupt Registers Read Only			20 ±10%		MHz
I ² C Operating Frequency	All registers, Fast-mode			400	kHz
	All registers, Standard-mode			100	kHz

Table 5 Other Electrical Specifications

3.5 I2C Timing Characterization

Typical Operating Circuit of section 4.2, VDD = 2.4V to 3.6V, VDDIO = 1.71 to VDD, T_A=25°C, unless otherwise noted.

Parameters	Conditions	Min	Typical	Max	Units	Notes
I²C TIMING						
I²C FAST-MODE						
f _{SCL} , SCL Clock Frequency				400	kHz	
t _{HD,STA} , (Repeated) START Condition Hold Time		0.6			μs	
t _{LOW} , SCL Low Period		1.3			μs	
t _{HIGH} , SCL High Period		0.6			μs	
t _{SU,STA} , Repeated START Condition Setup Time		0.6			μs	
t _{HD,DAT} , SDA Data Hold Time		0			μs	
t _{SU,DAT} , SDA Data Setup Time		100			ns	
t _r , SDA and SCL Rise Time	C _b bus cap. from 10 to 400pF	20+0.1C _b		300	ns	
t _f , SDA and SCL Fall Time	C _b bus cap. from 10 to 400pF	20+0.1C _b		300	ns	
t _{SU,STO} , STOP Condition Setup Time		0.6			μs	
t _{BUF} , Bus Free Time Between STOP and START Condition		1.3			μs	
C _b , Capacitive Load for each Bus Line			< 400		pF	
t _{VD,DAT} , Data Valid Time				0.9	μs	
t _{VD,ACK} , Data Valid Acknowledge Time				0.9	μs	

Table 6 I²C Timing Characteristics

Notes:

- Timing Characteristics apply to both Primary and Auxiliary I2C Bus
- Based on characterization of 5 parts over temperature and voltage as mounted on evaluation board or in sockets

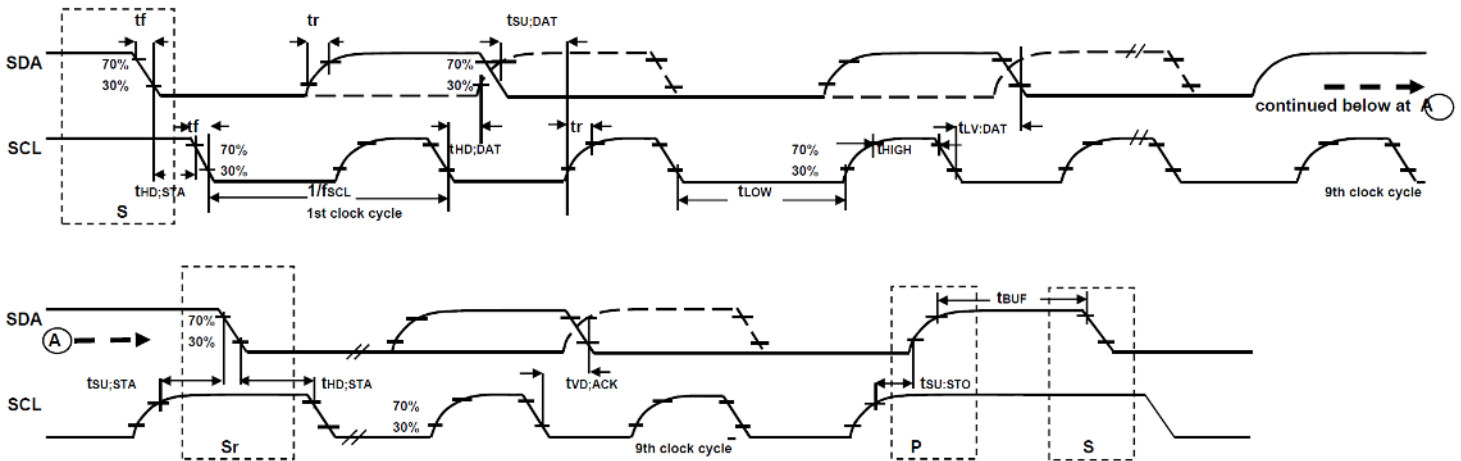

I²C Bus Timing Diagram

3.6 SPI Timing Characterization

Typical Operating Circuit of section 4.2, VDD = 2.4V to 3.6V, VDDIO = 1.71V to VDD, T_A=25°C, unless otherwise noted.

Parameters	Conditions	Min	Typical	Max	Units	Notes
SPI TIMING						
f _{SCLK} , SCLK Clock Frequency				1	MHz	
t _{LOW} , SCLK Low Period		400			ns	
t _{HIGH} , SCLK High Period		400			ns	
t _{SU,CS} , CS Setup Time		8			ns	
t _{HD,CS} , CS Hold Time		500			ns	
t _{SU,SDI} , SDI Setup Time		11			ns	
t _{HD,SDI} , SDI Hold Time		7			ns	
t _{VD,SDO} , SDO Valid Time	C _{load} = 20pF			100	ns	
t _{HD,SDO} , SDO Hold Time	C _{load} = 20pF	4			ns	
t _{DIS,SDO} , SDO Output Disable Time				50	ns	

Table 7 SPI Timing Characteristics

Notes:

1. Based on characterization of 5 parts over temperature and voltage as mounted on evaluation board or in sockets

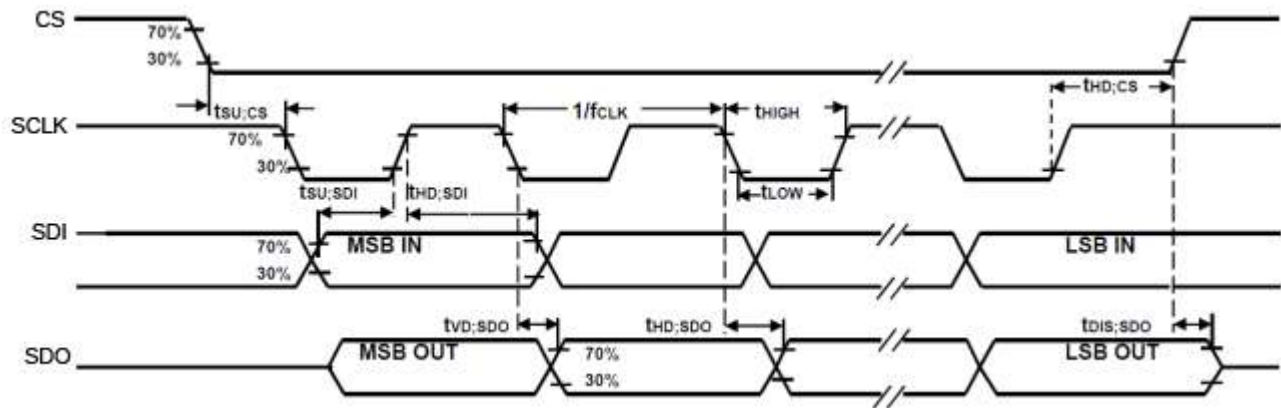

SPI Bus Timing Diagram

3.6.1 f_{SCLK} = 20MHz

Parameters	Conditions	Min	Typical	Max	Units
SPI TIMING					
f _{SCLK} , SCLK Clock Frequency		0.9		20	MHz
t _{LOW} , SCLK Low Period		-		-	ns
t _{HIGH} , SCLK High Period		-		-	ns
t _{SU,CS} , CS Setup Time		1			ns
t _{HD,CS} , CS Hold Time		1			ns

t _{SU,SDI} , SDI Setup Time		0			ns
t _{HD,SDI} , SDI Hold Time		1			ns
t _{VD,SDO} , SDO Valid Time	C _{load} = 20pF		25		ns
t _{DIS,SDO} , SDO Output Disable Time				25	ns

Table 8 fCLK = 20MHz

Note:

1. Based on characterization of 5 parts over temperature and voltage as mounted on evaluation board or in sockets

3.7 Absolute Maximum Ratings

Stress above those listed as “Absolute Maximum Ratings” may cause permanent damage to the device. These are stress ratings only and functional operation of the device at these conditions is not implied. Exposure to the absolute maximum ratings conditions for extended periods may affect device reliability.

Specification	Symbol	Conditions	MIN	MAX	Units
Supply Voltage	V _{DD}		-0.5	4.0	V
	V _{DDIO}		-0.5	4.0	V
Acceleration		Any axis, unpowered, 0.2ms duration		10,000	<i>g</i>
Temperature		Operating	-40	105	°C
		Storage	-40	125	°C
ESD Tolerance		HBM	2		KV
		MM	250		V

4 Applications Information

4.1 Pin Out and Signal Description

Pin Number	Pin Name	Pin Description
1	RESV	Reserved. Connect to VDDIO.
7	AUX_CL	I ² C Master serial clock, for connecting to external sensors
8	VDDIO	Digital I/O supply voltage
9	AD0 / SDO	I ² C Slave Address LSB (AD0); SPI serial data output (SDO)
10	REGOUT	Regulator filter capacitor connection
11	FSYNC	Frame synchronization digital input. Connect to GND if unused.
12	INT	Interrupt digital output (totem pole or open-drain)
13	VDD	Power supply voltage and Digital I/O supply voltage
18	GND	Power supply ground
19	RESV	Reserved. Do not connect.
20	RESV	Reserved. Connect to GND.
21	AUX_DA	I ² C master serial data, for connecting to external sensors
22	nCS	Chip select (SPI mode only)
23	SCL / SCLK	I ² C serial clock (SCL); SPI serial clock (SCLK)
24	SDA / SDI	I ² C serial data (SDA); SPI serial data input (SDI)
2 - 6, 14 - 17	NC	Not internally connected. May be used for PCB trace routing.

Table 9 Signal Descriptions

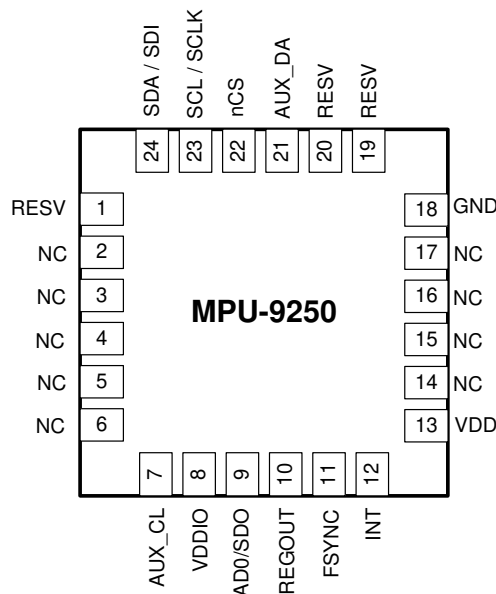

Figure 1 Pin Out Diagram for MPU-9250 3.0x3.0x1.0mm QFN

4.2 Typical Operating Circuit

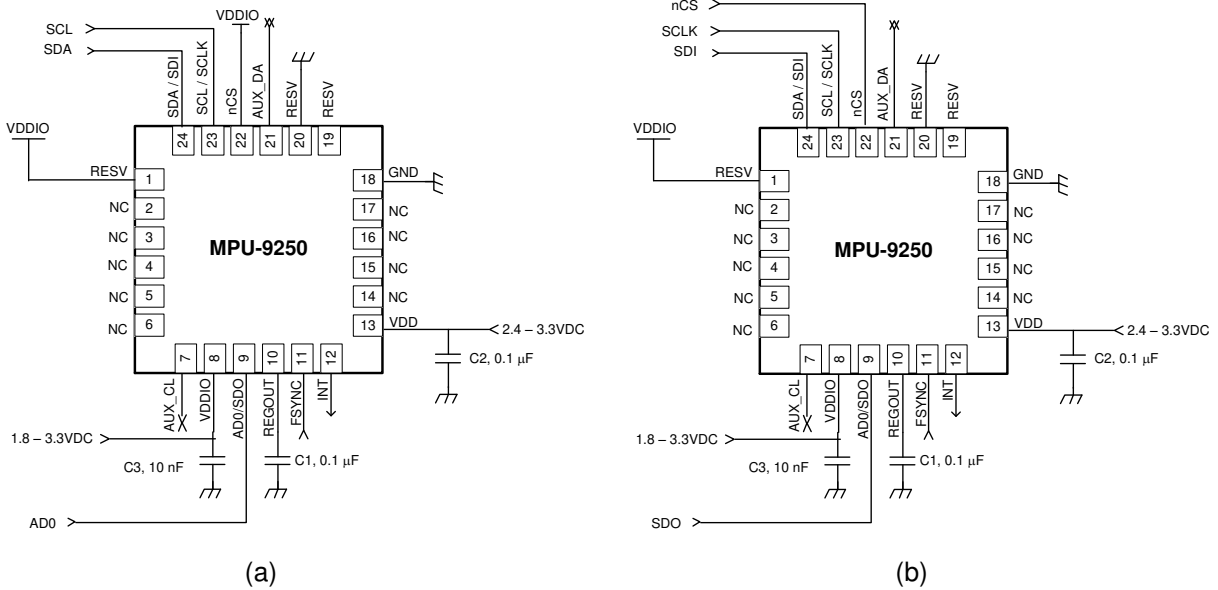

Figure 2 MPU-9250 QFN Application Schematic: (a) I2C operation, (b) SPI operation

Note that the INT pin should be connected to a GPIO pin on the system processor that is capable of waking the system processor from suspend mode.

4.3 Bill of Materials for External Components

Component	Label	Specification	Quantity
Regulator Filter Capacitor	C1	Ceramic, X7R, 0.1µF ±10%, 2V	1
VDD Bypass Capacitor	C2	Ceramic, X7R, 0.1µF ±10%, 4V	1
VDDIO Bypass Capacitor	C3	Ceramic, X7R, 10nF ±10%, 4V	1

Table 10 Bill of Materials

4.4 Block Diagram

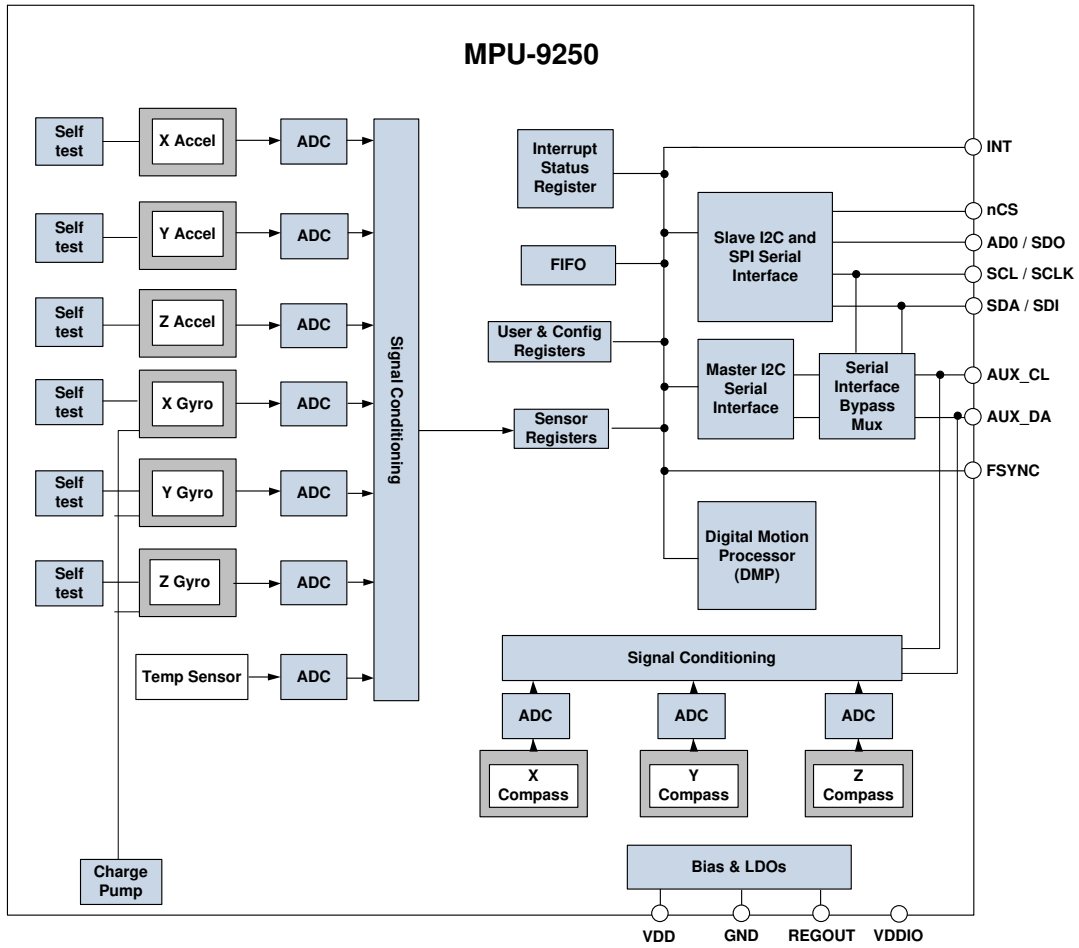

4.5 Overview

The MPU-9250 is comprised of the following key blocks and functions:

- Three-axis MEMS rate gyroscope sensor with 16-bit ADCs and signal conditioning
- Three-axis MEMS accelerometer sensor with 16-bit ADCs and signal conditioning
- Three-axis MEMS magnetometer sensor with 16-bit ADCs and signal conditioning
- Digital Motion Processor (DMP) engine
- Primary I²C and SPI serial communications interfaces
- Auxiliary I²C serial interface for 3rd party sensors
- Clocking
- Sensor Data Registers
- FIFO
- Interrupts
- Digital-Output Temperature Sensor
- Gyroscope, Accelerometer and Magnetometer Self-test
- Bias and LDO
- Charge Pump

4.6 Three-Axis MEMS Gyroscope with 16-bit ADCs and Signal Conditioning

The MPU-9250 consists of three independent vibratory MEMS rate gyroscopes, which detect rotation about the X-, Y-, and Z- Axes. When the gyros are rotated about any of the sense axes, the Coriolis Effect causes a vibration that is detected by a capacitive pickoff. The resulting signal is amplified, demodulated, and filtered to produce a voltage that is proportional to the angular rate. This voltage is digitized using individual on-chip 16-bit Analog-to-Digital Converters (ADCs) to sample each axis. The full-scale range of the gyro sensors may be digitally programmed to ± 250 , ± 500 , ± 1000 , or ± 2000 degrees per second (dps). The ADC sample rate is programmable from 8,000 samples per second, down to 3.9 samples per second, and user-selectable low-pass filters enable a wide range of cut-off frequencies.

4.7 Three-Axis MEMS Accelerometer with 16-bit ADCs and Signal Conditioning

The MPU-9250's 3-Axis accelerometer uses separate proof masses for each axis. Acceleration along a particular axis induces displacement on the corresponding proof mass, and capacitive sensors detect the displacement differentially. The MPU-9250's architecture reduces the accelerometers' susceptibility to fabrication variations as well as to thermal drift. When the device is placed on a flat surface, it will measure $0g$ on the X- and Y-axes and $+1g$ on the Z-axis. The accelerometers' scale factor is calibrated at the factory and is nominally independent of supply voltage. Each sensor has a dedicated sigma-delta ADC for providing digital outputs. The full scale range of the digital output can be adjusted to $\pm 2g$, $\pm 4g$, $\pm 8g$, or $\pm 16g$.

4.8 Three-Axis MEMS Magnetometer with 16-bit ADCs and Signal Conditioning

The 3-axis magnetometer uses highly sensitive Hall sensor technology. The magnetometer portion of the IC incorporates magnetic sensors for detecting terrestrial magnetism in the X-, Y-, and Z- Axes, a sensor driving circuit, a signal amplifier chain, and an arithmetic circuit for processing the signal from each sensor. Each ADC has a 16-bit resolution and a full scale range of $\pm 4800 \mu T$.

4.9 Digital Motion Processor

The embedded Digital Motion Processor (DMP) is located within the MPU-9250 and offloads computation of motion processing algorithms from the host processor. The DMP acquires data from accelerometers,

gyroscopes, magnetometers and additional 3rd party sensors, and processes the data. The resulting data can be read from the DMP's registers, or can be buffered in a FIFO. The DMP has access to one of the MPU's external pins, which can be used for generating interrupts. This pin (pin 12) should be connected to a pin on the host processor that can wake the host from suspend mode.

The purpose of the DMP is to offload both timing requirements and processing power from the host processor. Typically, motion processing algorithms should be run at a high rate, often around 200Hz, in order to provide accurate results with low latency. This is required even if the application updates at a much lower rate; for example, a low power user interface may update as slowly as 5Hz, but the motion processing should still run at 200Hz. The DMP can be used as a tool in order to minimize power, simplify timing, simplify the software architecture, and save valuable MIPS on the host processor for use in the application.

4.10 Primary I2C and SPI Serial Communications Interfaces

The MPU-9250 communicates to a system processor using either a SPI or an I²C serial interface. The MPU-9250 always acts as a slave when communicating to the system processor. The LSB of the of the I²C slave address is set by pin 9 (AD0).

4.11 Auxiliary I2C Serial Interface

The MPU-9250 has an auxiliary I²C bus for communicating to off-chip sensors. This bus has two operating modes:

- I²C Master Mode: The MPU-9250 acts as a master to any external sensors connected to the auxiliary I²C bus
- Pass-Through Mode: The MPU-9250 directly connects the primary and auxiliary I²C buses together, allowing the system processor to directly communicate with any external sensors.
- Note: AUX_DA and AUX_CL should be left unconnected if the Auxiliary I²C mode is not used.

Auxiliary I²C Bus Modes of Operation:

- I²C Master Mode: Allows the MPU-9250 to directly access the data registers of external digital sensors, such as a magnetometer. In this mode, the MPU-9250 directly obtains data from auxiliary sensors without intervention from the system applications processor.

For example, In I²C Master mode, the MPU-9250 can be configured to perform burst reads, returning the following data from a magnetometer:

- X magnetometer data (2 bytes)
- Y magnetometer data (2 bytes)
- Z magnetometer data (2 bytes)

The I²C Master can be configured to read up to 24 bytes from up to 4 auxiliary sensors. A fifth sensor can be configured to work single byte read/write mode.

- Pass-Through Mode: Allows an external system processor to act as master and directly communicate to the external sensors connected to the auxiliary I²C bus pins (AUX_DA and AUX_CL). In this mode, the auxiliary I²C bus control logic (3rd party sensor interface block) of the MPU-9250 is disabled, and the auxiliary I²C pins AUX_DA and AUX_CL are connected to the main I²C bus through analog switches internally.

Pass-Through mode is useful for configuring the external sensors, or for keeping the MPU-9250 in a low-power mode when only the external sensors are used. In this mode, the system processor can still access MPU-9250 data through the I²C interface.

Pass-Through mode is also used to access the AK8963 magnetometer directly from the host. In this configuration the slave address for the AK8963 is 0X0C or 12 decimal.

Auxiliary I²C Bus IO Logic Levels

For MPU-9250, the logic level of the auxiliary I²C bus is VDDIO. For further information regarding the MPU-9250 logic levels, please refer to Section 10.2.

4.12 Self-Test

Please refer to the register map document for more details on self-test.

Self-test allows for the testing of the mechanical and electrical portions of the sensors. The self-test for each measurement axis can be activated by means of the gyroscope and accelerometer self-test registers (registers 13 to 16).

When the self-test is activated, the electronics cause the sensors to be actuated and produce an output signal. The output signal is used to observe the self-test response.

The self-test response is defined as follows:

$$\text{Self-test response} = \text{Sensor output with self-test enabled} - \text{Sensor output without self-test enabled}$$

When the value of the self-test response is within the appropriate limits, the part has passed self-test. When the self-test response exceeds the appropriate values, the part is deemed to have failed self-test. It is recommended to use InvenSense MotionApps software for executing self-test. Further details, including the self-test limits are included in the MPU-9250 Self-Test applications note available from InvenSense.

4.13 MPU-9250 Solution Using I2C Interface

In the figure below, the system processor is an I²C master to the MPU-9250. In addition, the MPU-9250 is an I²C master to the optional external 3rd party sensor. The MPU-9250 has limited capabilities as an I²C Master, and depends on the system processor to manage the initial configuration of any auxiliary sensors. The MPU-9250 has an interface bypass multiplexer, which connects the system processor I²C bus (SDA and SCL) directly to the auxiliary sensor I²C bus (AUX_DA and AUX_CL).

Once the auxiliary sensors have been configured by the system processor, the interface bypass multiplexer should be disabled so that the MPU-9250 auxiliary I²C master can take control of the sensor I²C bus and gather data from the auxiliary sensors. The INT pin should be connected to a GPIO on the system processor that can wake the system from suspend mode.

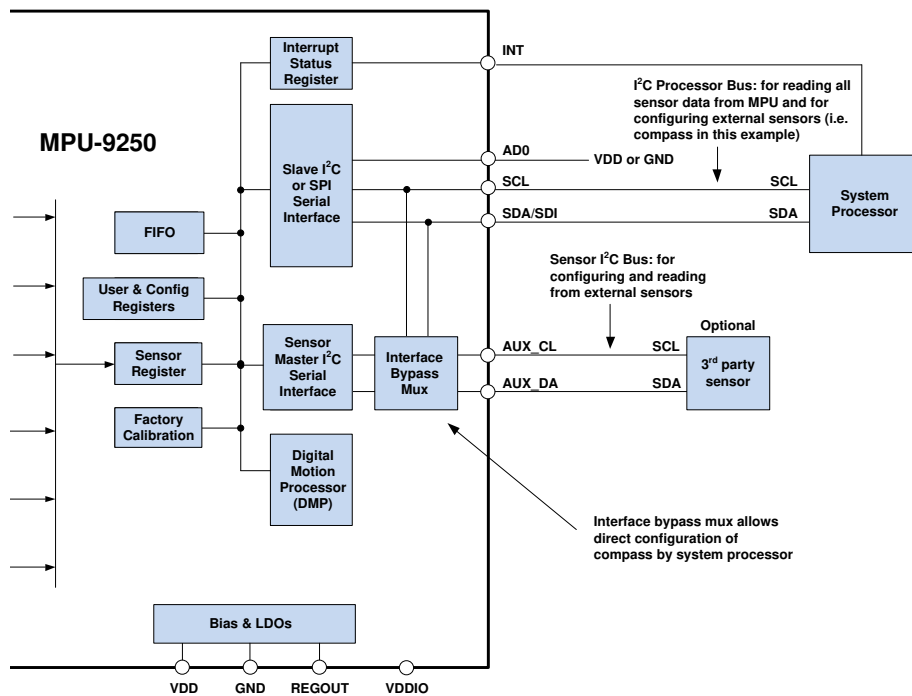

4.14 MPU-9250 Solution Using SPI Interface

In the figure below, the system processor is a SPI master to the MPU-9250. The CS, SDO, SCLK, and SDI signals are used for SPI communications. Because these SPI pins are shared with the I²C slave pins, the system processor cannot access the auxiliary I²C bus through the interface bypass multiplexer, which connects the processor I²C interface pins to the sensor I²C interface pins.

Since the MPU-9250 has limited capabilities as an I²C Master, and depends on the system processor to manage the initial configuration of any auxiliary sensors, another method must be used for programming the sensors on the auxiliary sensor I²C bus (AUX_DA and AUX_CL).

When using SPI communications between the MPU-9250 and the system processor, configuration of devices on the auxiliary I²C sensor bus can be achieved by using I²C Slaves 0-4 to perform read and write transactions on any device and register on the auxiliary I²C bus. The I²C Slave 4 interface can be used to perform only single byte read and write transactions.

Once the external sensors have been configured, the MPU-9250 can perform single or multi-byte reads using the sensor I²C bus. The read results from the Slave 0-3 controllers can be written to the FIFO buffer as well as to the external sensor registers.

The INT pin should be connected to a GPIO on the system processor capable of waking the processor from suspend

For further information regarding the control of the MPU-9250's auxiliary I²C interface, please refer to the MPU-9250 Register Map and Register Descriptions document.

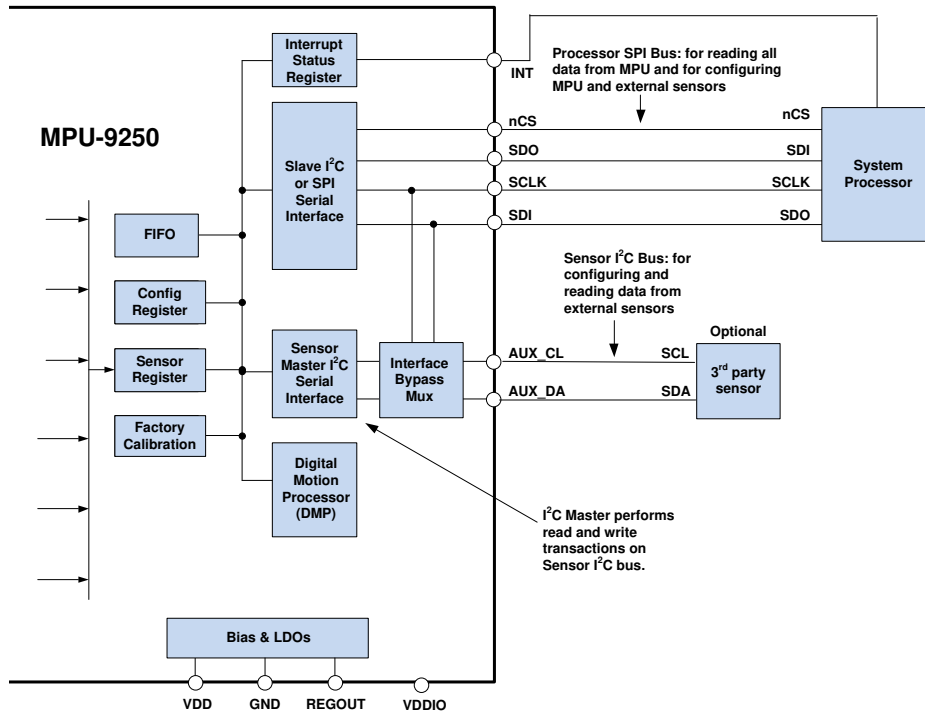

4.15 Clocking

The MPU-9250 has a flexible clocking scheme, allowing a variety of internal clock sources to be used for the internal synchronous circuitry. This synchronous circuitry includes the signal conditioning and ADCs, the DMP, and various control circuits and registers. An on-chip PLL provides flexibility in the allowable inputs for generating this clock.

Allowable internal sources for generating the internal clock are:

- An internal relaxation oscillator
- Any of the X, Y, or Z gyros (MEMS oscillators with a variation of $\pm 1\%$ over temperature)

Selection of the source for generating the internal synchronous clock depends on the requirements for power consumption and clock accuracy. These requirements will most likely vary by mode of operation. For example, in one mode, where the biggest concern is power consumption, the user may wish to operate the Digital Motion Processor of the MPU-9250 to process accelerometer data, while keeping the gyros off. In this case, the internal relaxation oscillator is a good clock choice. However, in another mode, where the gyros are active, selecting the gyros as the clock source provides for a more accurate clock source.

Clock accuracy is important, since timing errors directly affect the distance and angle calculations performed by the Digital Motion Processor (and by extension, by any processor).

There are also start-up conditions to consider. When the MPU-9250 first starts up, the device uses its internal clock until programmed to operate from another source. This allows the user, for example, to wait for the MEMS oscillators to stabilize before they are selected as the clock source.

4.16 Sensor Data Registers

The sensor data registers contain the latest gyroscope, accelerometer, magnetometer, auxiliary sensor, and temperature measurement data. They are read-only registers, and are accessed via the serial interface. Data from these registers may be read anytime.

4.17 FIFO

The MPU-9250 contains a 512-byte FIFO register that is accessible via the Serial Interface. The FIFO configuration register determines which data is written into the FIFO. Possible choices include gyro data, accelerometer data, temperature readings, auxiliary sensor readings, and FSYNC input. A FIFO counter keeps track of how many bytes of valid data are contained in the FIFO. The FIFO register supports burst reads. The interrupt function may be used to determine when new data is available.

For further information regarding the FIFO, please refer to the MPU-9250 Register Map and Register Descriptions document.

4.18 Interrupts

Interrupt functionality is configured via the Interrupt Configuration register. Items that are configurable include the INT pin configuration, the interrupt latching and clearing method, and triggers for the interrupt. Items that can trigger an interrupt are (1) Clock generator locked to new reference oscillator (used when switching clock sources); (2) new data is available to be read (from the FIFO and Data registers); (3) accelerometer event interrupts; and (4) the MPU-9250 did not receive an acknowledge from an auxiliary sensor on the secondary I²C bus. The interrupt status can be read from the Interrupt Status register.

The INT pin should be connected to a pin on the host processor capable of waking that processor from suspend.

For further information regarding interrupts, please refer to the MPU-9250 Register Map and Register Descriptions document.

4.19 Digital-Output Temperature Sensor

An on-chip temperature sensor and ADC are used to measure the MPU-9250 die temperature. The readings from the ADC can be read from the FIFO or the Sensor Data registers.

4.20 Bias and LDO

The bias and LDO section generates the internal supply and the reference voltages and currents required by the MPU-9250. Its two inputs are an unregulated VDD and a VDDIO logic reference supply voltage. The LDO output is bypassed by a capacitor at REGOUT. For further details on the capacitor, please refer to the Bill of Materials for External Components.

4.21 Charge Pump

An on-chip charge pump generates the high voltage required for the MEMS oscillators.

4.22 Standard Power Mode

The following table lists the user-accessible power modes for MPU-9250.

Mode	Name	Gyro	Accel	Magnetometer	DMP
1	Sleep Mode	Off	Off	Off	Off
2	Standby Mode	Drive On	Off	Off	Off
3	Low-Power Accelerometer Mode	Off	Duty-Cycled	Off	On or Off
4	Low-Noise Accelerometer Mode	Off	On	Off	On or Off
5	Gyroscope Mode	On	Off	Off	On or Off
6	Magnetometer Mode	Off	Off	On	On or Off
7	Accel + Gyro Mode	On	On	Off	On or Off
8	Accel + Magnetometer Mode	Off	On	On	On or Off
9	9-Axis Mode	On	On	On	On or Off

Notes:

1. Power consumption for individual modes can be found in Electrical Characteristics section.

4.23 Power Sequencing Requirements and Power on Reset

During power up and in normal operation, VDDIO must not exceed VDD. During power up, VDD and VDDIO must be monotonic ramps. As stated in Table 4, the minimum VDD rise time is 0.1ms and the maximum rise time is 100 ms. Valid gyroscope data is available 35 ms (typical) after VDD has risen to its final voltage from a cold start and valid accelerometer data is available 30 ms (typical) after VDD has risen to its final voltage assuming a 1ms VDD ramp from cold start. Magnetometer data is valid 7.3ms (typical) after VDD has risen to its final voltage value from a cold start.

5 Advanced Hardware Features

The MPU-9250 includes advanced hardware features that can be enabled and disabled through simple hardware register settings. The advanced hardware features are not initially enabled after device power up. These features must be individually enabled and configured. These advanced hardware features enable the following motion-based functions without using an external microprocessor:

- Low Power Quaternion (3-Axis Gyro & 6-Axis Gyro + Accel)
- Android Orientation (A low-power implementation of Android's screen rotation algorithm)
- Tap (detects the tap gesture)
- Pedometer
- Significant Motion Detection

To ensure significant motion detection can operate properly, the INT pin should be connected to a GPIO pin on the host processor that can wake that processor from suspend mode.

Note: Android Orientation is compliant to the Ice Cream Sandwich definition of the function.

For further details on advanced hardware features please refer to the MPU-9250 Register Map.

6 Programmable Interrupts

The MPU-9250 has a programmable interrupt system which can generate an interrupt signal on the INT pin. Status flags indicate the source of an interrupt. Interrupt sources may be enabled and disabled individually.

Table of Interrupt Sources

Interrupt Name	Module
Motion Detection	Motion
FIFO Overflow	FIFO
Data Ready	Sensor Registers
I ² C Master errors: Lost Arbitration, NACKs	I ² C Master
I ² C Slave 4	I ² C Master

For information regarding the interrupt enable/disable registers and flag registers, please refer to the MPU-9250 Register Map and Register Descriptions document. Some interrupt sources are explained below.

6.1 Wake-on-Motion Interrupt

The MPU-9250 provides motion detection capability. A qualifying motion sample is one where the high passed sample from any axis has an absolute value exceeding a user-programmable threshold. The following flowchart explains how to configure the Wake-on-Motion Interrupt. For further details on individual registers, please refer to the MPU-9250 Registers Map and Registers Description document.

In order to properly enable motion interrupts, the INT pin should be connected to a GPIO on the system processor that is capable of waking up the system processor.

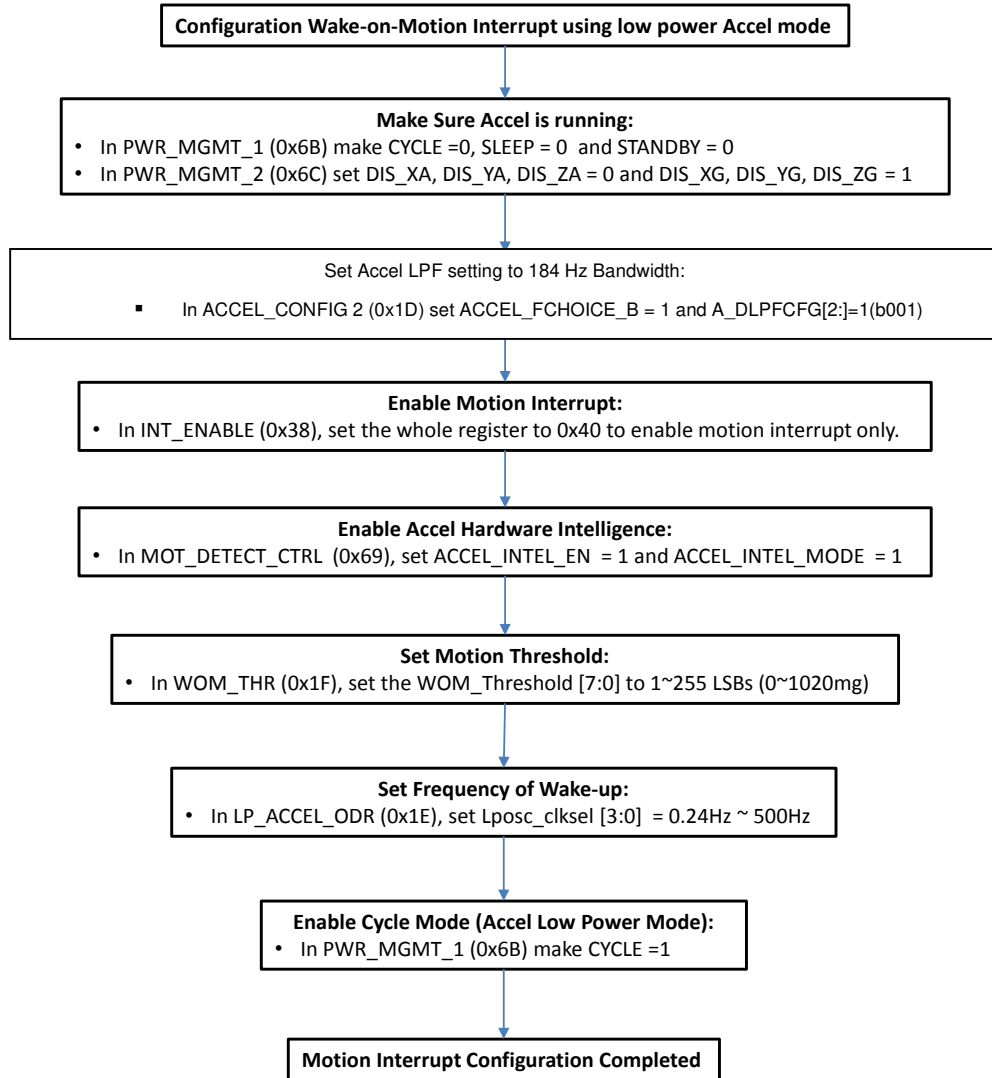

Figure 3. Wake-on-Motion Interrupt Configuration

7 Digital Interface

7.1 I2C and SPI Serial Interfaces

The internal registers and memory of the MPU-9250 can be accessed using either I²C at 400 kHz or SPI at 1MHz. SPI operates in four-wire mode.

Serial Interface

Pin Number	Pin Name	Pin Description
8	VDDIO	Digital I/O supply voltage.
9	AD0 / SDO	I ² C Slave Address LSB (AD0); SPI serial data output (SDO)
23	SCL / SCLK	I ² C serial clock (SCL); SPI serial clock (SCLK)
24	SDA / SDI	I ² C serial data (SDA); SPI serial data input (SDI)

Note:

To prevent switching into I²C mode when using SPI, the I²C interface should be disabled by setting the *I2C_IF_DIS* configuration bit. Setting this bit should be performed immediately after waiting for the time specified by the “Start-Up Time for Register Read/Write” in Section 6.3.

For further information regarding the *I2C_IF_DIS* bit, please refer to the MPU-9250 Register Map and Register Descriptions document.

7.2 I2C Interface

I²C is a two-wire interface comprised of the signals serial data (SDA) and serial clock (SCL). In general, the lines are open-drain and bi-directional. In a generalized I²C interface implementation, attached devices can be a master or a slave. The master device puts the slave address on the bus, and the slave device with the matching address acknowledges the master.

The MPU-9250 always operates as a slave device when communicating to the system processor, which thus acts as the master. SDA and SCL lines typically need pull-up resistors to VDD. The maximum bus speed is 400 kHz.

The slave address of the MPU-9250 is b110100X which is 7 bits long. The LSB bit of the 7 bit address is determined by the logic level on pin AD0. This allows two MPU-9250s to be connected to the same I²C bus. When used in this configuration, the address of the one of the devices should be b1101000 (pin AD0 is logic low) and the address of the other should be b1101001 (pin AD0 is logic high).

7.3 I2C Communications Protocol

START (S) and STOP (P) Conditions

Communication on the I²C bus starts when the master puts the START condition (S) on the bus, which is defined as a HIGH-to-LOW transition of the SDA line while SCL line is HIGH (see figure below). The bus is considered to be busy until the master puts a STOP condition (P) on the bus, which is defined as a LOW to HIGH transition on the SDA line while SCL is HIGH (see figure below).

Additionally, the bus remains busy if a repeated START (Sr) is generated instead of a STOP condition.

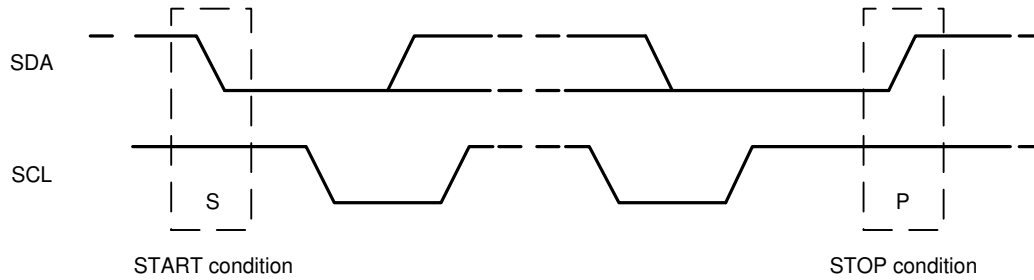

START and STOP Conditions

Data Format / Acknowledge

I²C data bytes are defined to be 8-bits long. There is no restriction to the number of bytes transmitted per data transfer. Each byte transferred must be followed by an acknowledge (ACK) signal. The clock for the acknowledge signal is generated by the master, while the receiver generates the actual acknowledge signal by pulling down SDA and holding it low during the HIGH portion of the acknowledge clock pulse.

If a slave is busy and cannot transmit or receive another byte of data until some other task has been performed, it can hold SCL LOW, thus forcing the master into a wait state. Normal data transfer resumes when the slave is ready, and releases the clock line (refer to the following figure).

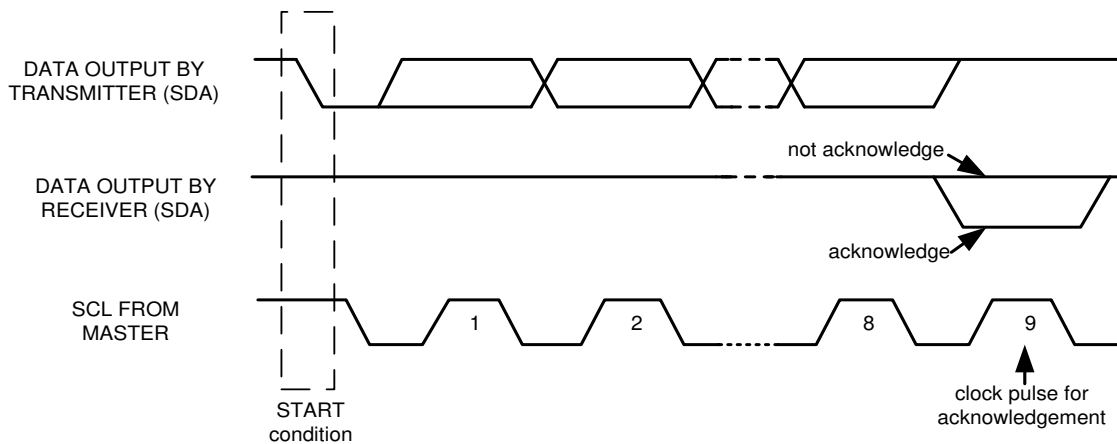

Acknowledge on the I²C Bus

Communications

After beginning communications with the START condition (S), the master sends a 7-bit slave address followed by an 8th bit, the read/write bit. The read/write bit indicates whether the master is receiving data from or is writing to the slave device. Then, the master releases the SDA line and waits for the acknowledge signal (ACK) from the slave device. Each byte transferred must be followed by an acknowledge bit. To acknowledge, the slave device pulls the SDA line LOW and keeps it LOW for the high period of the SCL line. Data transmission is always terminated by the master with a STOP condition (P), thus freeing the communications line. However, the master can generate a repeated START condition (Sr), and address another slave without first generating a STOP condition (P). A LOW to HIGH transition on the SDA line while SCL is HIGH defines the stop condition. All SDA changes should take place when SCL is low, with the exception of start and stop conditions.

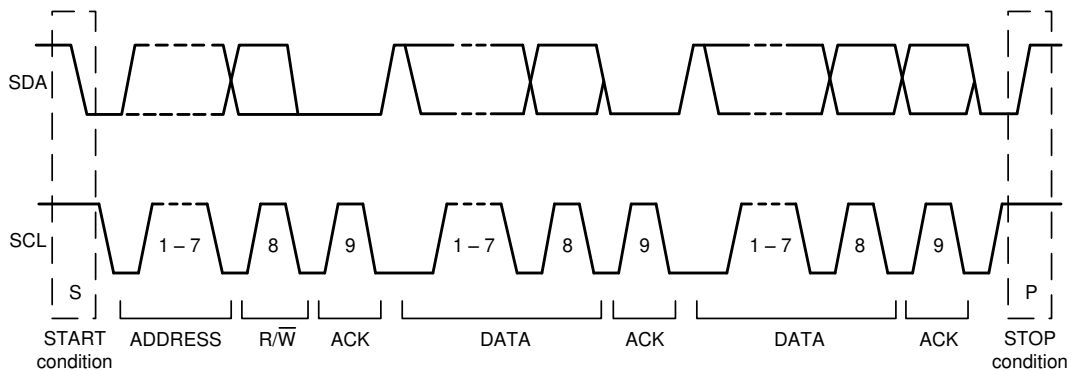

Complete I²C Data Transfer

To write the internal MPU-9250 registers, the master transmits the start condition (S), followed by the I²C address and the write bit (0). At the 9th clock cycle (when the clock is high), the MPU-9250 acknowledges the transfer. Then the master puts the register address (RA) on the bus. After the MPU-9250 acknowledges the reception of the register address, the master puts the register data onto the bus. This is followed by the ACK signal, and data transfer may be concluded by the stop condition (P). To write multiple bytes after the last ACK signal, the master can continue outputting data rather than transmitting a stop signal. In this case, the MPU-9250 automatically increments the register address and loads the data to the appropriate register. The following figures show single and two-byte write sequences.

Single-Byte Write Sequence

Master	S	AD+W		RA		DATA		P
Slave			ACK		ACK		ACK	

Burst Write Sequence

Master	S	AD+W		RA		DATA		DATA		P
Slave			ACK		ACK		ACK		ACK	

To read the internal MPU-9250 registers, the master sends a start condition, followed by the I²C address and a write bit, and then the register address that is going to be read. Upon receiving the ACK signal from the MPU-9250, the master transmits a start signal followed by the slave address and read bit. As a result, the MPU-9250 sends an ACK signal and the data. The communication ends with a not acknowledge (NACK) signal and a stop bit from master. The NACK condition is defined such that the SDA line remains high at the 9th clock cycle. The following figures show single and two-byte read sequences.

Single-Byte Read Sequence

Master	S	AD+W		RA		S	AD+R			NACK	P
Slave			ACK		ACK			ACK	DATA		

Burst Read Sequence

Master	S	AD+W		RA		S	AD+R			ACK		NACK	P
Slave			ACK		ACK			ACK	DATA		DATA		

7.4 I2C Terms

Signal	Description
S	Start Condition: SDA goes from high to low while SCL is high
AD	Slave I ² C address
W	Write bit (0)
R	Read bit (1)
ACK	Acknowledge: SDA line is low while the SCL line is high at the 9 th clock cycle
NACK	Not-Acknowledge: SDA line stays high at the 9 th clock cycle
RA	MPU-9250 internal register address
DATA	Transmit or received data
P	Stop condition: SDA going from low to high while SCL is high

7.5 SPI Interface

SPI is a 4-wire synchronous serial interface that uses two control lines and two data lines. The MPU-9250 always operates as a Slave device during standard Master-Slave SPI operation.

With respect to the Master, the Serial Clock output (SCLK), the Serial Data Output (SDO) and the Serial Data Input (SDI) are shared among the Slave devices. Each SPI slave device requires its own Chip Select (CS) line from the master.

CS goes low (active) at the start of transmission and goes back high (inactive) at the end. Only one CS line is active at a time, ensuring that only one slave is selected at any given time. The CS lines of the non-selected slave devices are held high, causing their SDO lines to remain in a high-impedance (high-z) state so that they do not interfere with any active devices.

SPI Operational Features

1. Data is delivered MSB first and LSB last
2. Data is latched on the rising edge of SCLK
3. Data should be transitioned on the falling edge of SCLK
4. The maximum frequency of SCLK is 1MHz
5. SPI read and write operations are completed in 16 or more clock cycles (two or more bytes). The first byte contains the SPI Address, and the following byte(s) contain(s) the SPI data. The first bit of the first byte contains the Read/Write bit and indicates the Read (1) or Write (0) operation. The following 7 bits contain the Register Address. In cases of multiple-byte Read/Writes, data is two or more bytes:

SPI Address format

MSB							LSB
R/W	A6	A5	A4	A3	A2	A1	A0

SPI Data format

MSB							LSB
D7	D6	D5	D4	D3	D2	D1	D0

6. Supports Single or Burst Read/Writes.

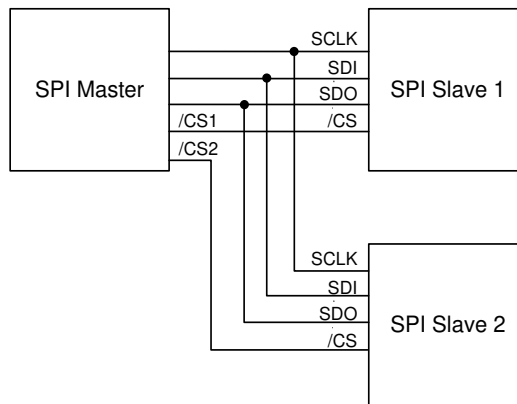

Typical SPI Master / Slave Configuration

8 Serial Interface Considerations

8.1 MPU-9250 Supported Interfaces

The MPU-9250 supports I²C communications on both its primary (microprocessor) serial interface and its auxiliary interface.

The MPU-9250's I/O logic levels are set to be VDDIO.

The figure below depicts a sample circuit of MPU-9250 with a third party sensor attached to the auxiliary I²C bus. It shows the relevant logic levels and voltage connections.

Note: Actual configuration will depend on the auxiliary sensors used.

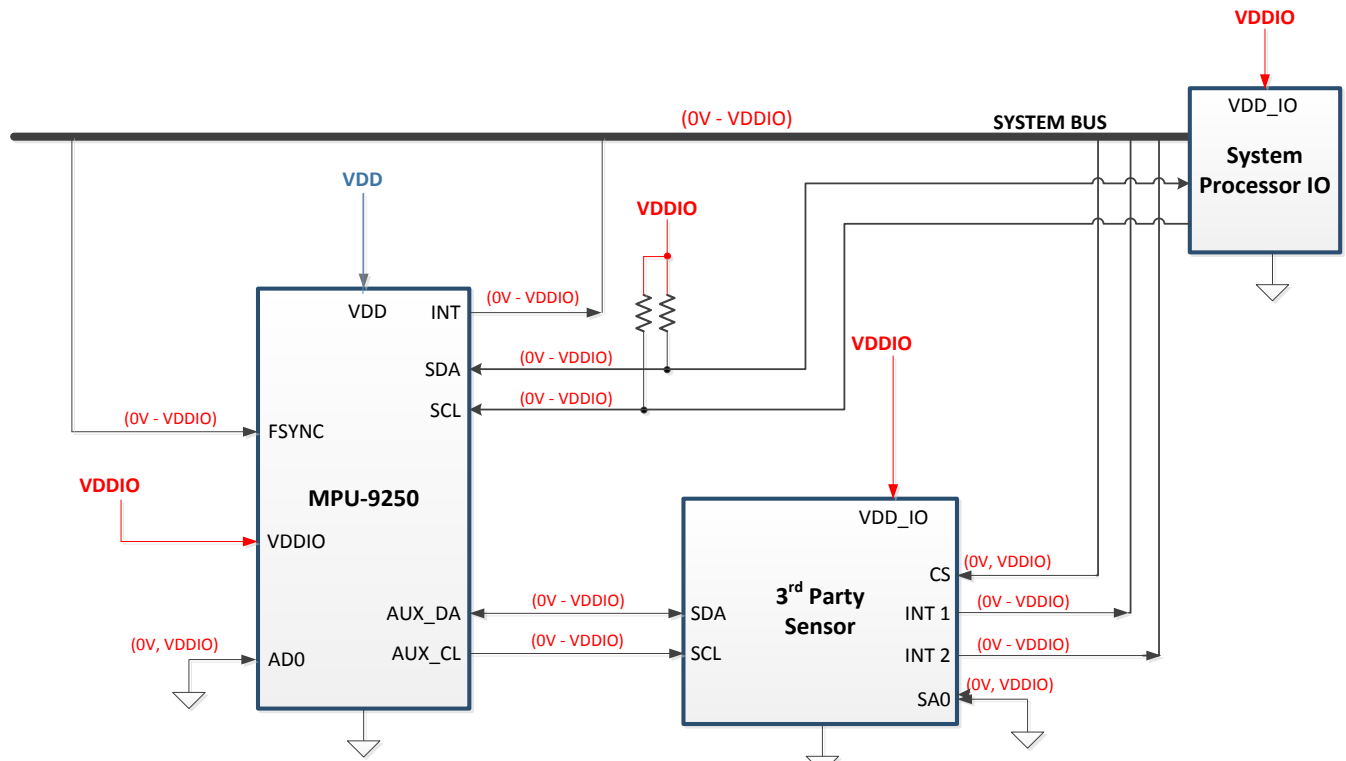

I/O Levels and Connections

9 Assembly

This section provides general guidelines for assembling InvenSense Micro Electro-Mechanical Systems (MEMS) devices packaged in quad flat no-lead package (QFN) surface mount integrated circuits.

9.1 Orientation of Axes

The diagram below shows the orientation of the axes of sensitivity and the polarity of rotation. Note the pin 1 identifier (•) in the figure.

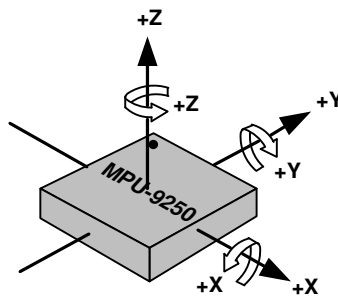

Figure 4. Orientation of Axes of Sensitivity and Polarity of Rotation for Accelerometer and Gyroscope

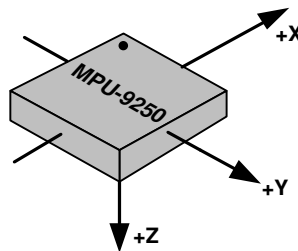
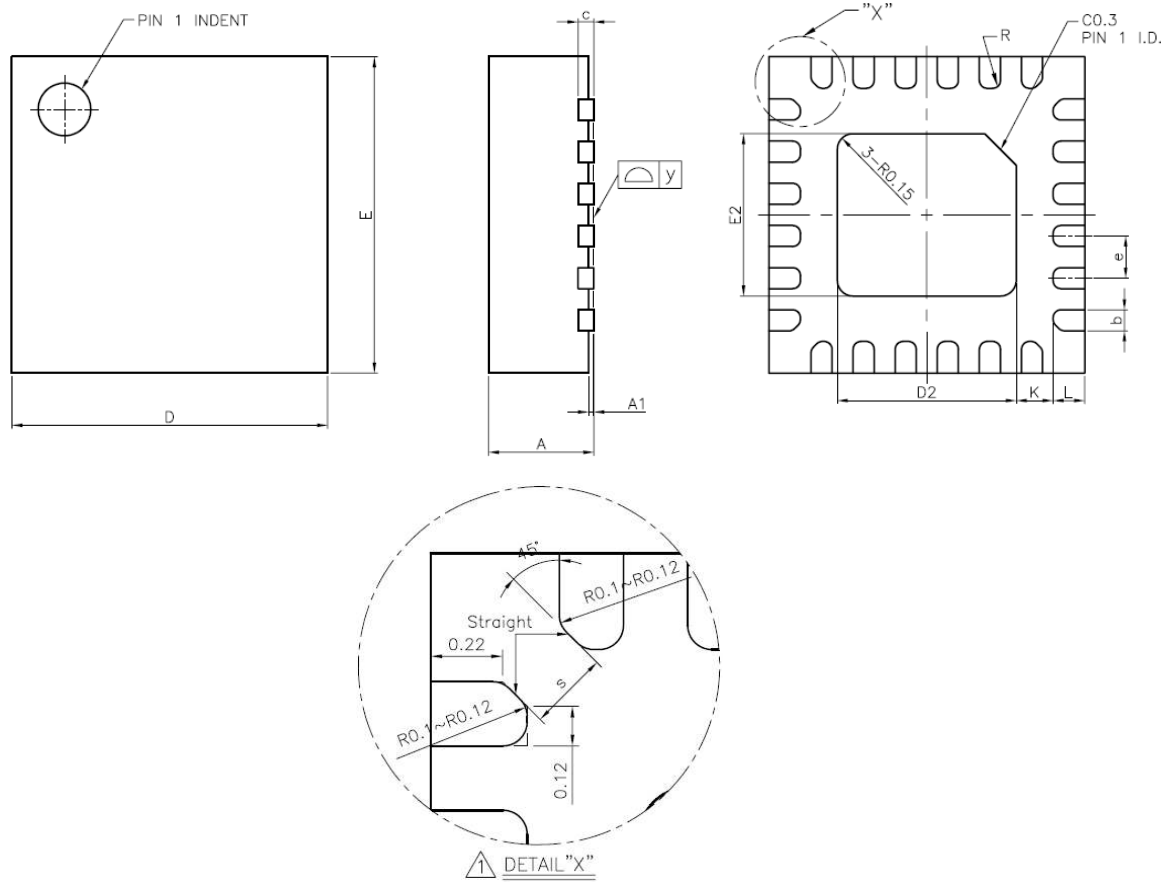

Figure 5. Orientation of Axes of Sensitivity for Compass

9.2 Package Dimensions

24 Lead QFN (3x3x1) mm NiPdAu Lead-frame finish



SYMBOLS	DESCRIPTION	DIMENSIONS IN MILLIMETERS		
		MIN	NOM	MAX
A	Package thickness	0.95	1.00	1.05
A1	Lead finger (pad) seating height	0.00	0.02	0.05
b	Lead finger (pad) width	0.15	0.20	0.25
c	Lead frame (pad) height	---	0.15 REF	---
D	Package width	2.90	3.00	3.10
D2	Exposed pad width	1.65	1.70	1.75
E	Package length	2.90	3.00	3.10
E2	Exposed pad length	1.49	1.54	1.59
e	Lead finger-finger (pad-pad) pitch	---	0.40	---
f (e-b)	Lead-lead (Pad-Pad) space	0.15	0.20	0.25
K	Lead (pad) to Exposed Pad Space	---	0.35 REF	---
L	Lead (pad) length	0.25	0.30	0.35
R	Lead (pad) corner radius	0.075	REF	---
s	Corner lead (pad) outer radius to corner lead outer radius	---	0.25 REF	---
y		0.00	---	0.075

10 Part Number Package Marking

The part number package marking for MPU-9250 devices is summarized below:

Part Number	Part Number Package Marking
MPU-9250	MP92

11 Reliability

11.1 Qualification Test Policy

InvenSense's products complete a Qualification Test Plan before being released to production. The Qualification Test Plan for the MPU-9250 followed the JEDEC JESD 471 Standard, "Stress-Test-Driven Qualification of Integrated Circuits," with the individual tests described below.

11.2 Qualification Test Plan

Accelerated Life Tests

TEST	Method/Condition	Lot Quantity	Sample / Lot	Acc / Reject Criteria
(HTOL/LFR) High Temperature Operating Life	JEDEC JESD22-A108D Dynamic, 3.63V biased, $T_j > 125^\circ\text{C}$ [read-points: 168, 500, 1000 hours]	3	77	(0/1)
(HAST) Highly Accelerated Stress Test ⁽¹⁾	JEDEC JESD22-A118A Condition A, 130°C , 85%RH, 33.3 psia., unbiased [read-point: 96 hours]	3	77	(0/1)
(HTS) High Temperature Storage Life	JEDEC JESD22-A103D Condition A, 125°C Non-Bias Bake [read-points: 168, 500, 1000 hours]	3	77	(0/1)

Device Component Level Tests

TEST	Method/Condition	Lot Quantity	Sample / Lot	Acc / Reject Criteria
(ESD-HBM) ESD-Human Body Model	JEDEC JS-001-2012 (2KV)	1	3	(0/1)
(ESD-MM) ESD-Machine Model	JEDEC JESD22-A115C (250V)	1	3	(0/1)
(ESD-CDM) ESD-Charged Device Model	JEDEC JESD22-C101E (500V)	1	3	(0/1)
(LU) Latch Up	JEDEC JESD-78D Class II (2), 125°C ; $\pm 100\text{mA}$ 1.5X Vdd Over-voltage	1	6	(0/1)
(MS) Mechanical Shock	JEDEC JESD22-B104C, Mil-Std-883, Method 2002.5 Cond. E, $10,000g$'s, 0.2ms, $\pm X, Y, Z$ – 6 directions, 5 times/direction	3	5	(0/1)
(VIB) Vibration	JEDEC JESD22-B103B Variable Frequency (random), Cond. B, 5-500Hz, X, Y, Z – 4 times/direction	1	5	(0/1)
(TC) Temperature Cycling ⁽¹⁾	JEDEC JESD22-A104D Condition G [-40°C to $+125^\circ\text{C}$], Soak Mode 2 [5'] [read-Point: 1000 cycles]	3	77	(0/1)

(1) Tests are preceded by MSL3 Preconditioning in accordance with JEDEC JESD22-A113F

12 Reference

Please refer to “InvenSense MEMS Handling Application Note (AN-IVS-0002A-00)” for the following information:

- Manufacturing Recommendations
 - Assembly Guidelines and Recommendations
 - PCB Design Guidelines and Recommendations
 - MEMS Handling Instructions
 - ESD Considerations
 - Reflow Specification
 - Storage Specifications
 - Package Marking Specification
 - Tape & Reel Specification
 - Reel & Pizza Box Label
 - Packaging
 - Representative Shipping Carton Label
- Compliance
 - Environmental Compliance
 - DRC Compliance
 - Compliance Declaration Disclaimer

This information furnished by InvenSense is believed to be accurate and reliable. However, no responsibility is assumed by InvenSense for its use, or for any infringements of patents or other rights of third parties that may result from its use. Specifications are subject to change without notice. InvenSense reserves the right to make changes to this product, including its circuits and software, in order to improve its design and/or performance, without prior notice. InvenSense makes no warranties, neither expressed nor implied, regarding the information and specifications contained in this document. InvenSense assumes no responsibility for any claims or damages arising from information contained in this document, or from the use of products and services detailed therein. This includes, but is not limited to, claims or damages based on the infringement of patents, copyrights, mask work and/or other intellectual property rights.

Certain intellectual property owned by InvenSense and described in this document is patent protected. No license is granted by implication or otherwise under any patent or patent rights of InvenSense. This publication supersedes and replaces all information previously supplied. Trademarks that are registered trademarks are the property of their respective companies. InvenSense sensors should not be used or sold in the development, storage, production or utilization of any conventional or mass-destructive weapons or for any other weapons or life threatening applications, as well as in any other life critical applications such as medical equipment, transportation, aerospace and nuclear instruments, undersea equipment, power plant equipment, disaster prevention and crime prevention equipment.

©2014 InvenSense, Inc. All rights reserved. InvenSense, MotionTracking, MotionProcessing, MotionProcessor, MotionFusion, MotionApps, DMP, and the InvenSense logo are trademarks of InvenSense, Inc. Other company and product names may be trademarks of the respective companies with which they are associated.

©2014 InvenSense, Inc. All rights reserved.

