

Features

- Highly Integrated - All-in-one Active Antenna IC
- Integrated AGC for AM and FM
- Integrated Driver for AM and FM PIN Diodes
- Integrated Power Supply Regulator
- Integrated Antenna Sensor
- Separated AM LNA, AM Buffer and FM Amplifier
- High Dynamic Range for AM and FM
- Excellent Noise Performance
- High Intercept Point 3rd Order for FM
- FM Amplifier Adjustable to Various Cable Impedances
- High Intercept Point 2nd and 3rd Order for AM
- Low Noise Output Voltage
- Low Power Consumption
- Low Output Impedance AM
- Only Small Capacitor Values Necessary at AM AGC
- Large AM Frequency Range to Cover DRM Broadcast Signals

1. Description

The ATR4252 is a highly integrated high performance AM/FM antenna amplification IC with several features. The device has built-in AGC's for both AM and FM, antenna detection, a power supply regulator as well as additional pre-integrated peripherals.

The ATR4252 is based on BICMOS technology. The device is designed in particular for car application and is suitable for active antennas located in several positions on the car such as bumpers, windscreen, mirrors or windows.

Figure 1-1. Block Diagram

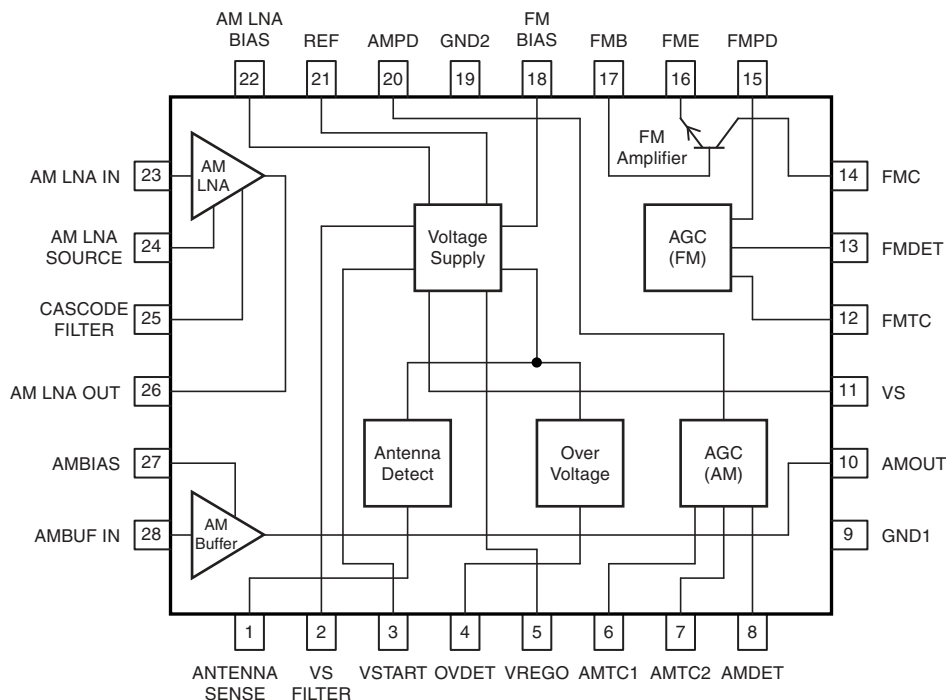

All-in-One IC Solution for Active Antennas

ATR4252

Summary

NOTE: This is a summary document. The complete document is available under NDA. For more information, please contact your local Atmel sales office.



2. Pin Configuration

Figure 2-1. Pinning VQFN 4x5 / 28L

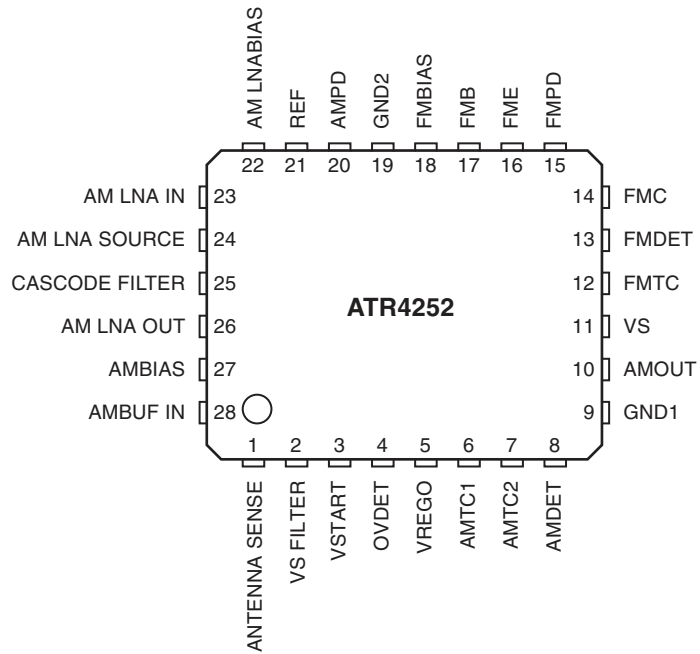

Table 2-1. Pin Description

Pin	Symbol	Function
1	ANTENNA SENSE	Antenna sense input
2	VS FILTER	Supply voltage filter input
3	VSTART	Comparator input of voltage detector
4	OVDET	Overvoltage detection input
5	VREGO	Output of voltage regulator
6	AMTC1	AM AGC time-constant capacitance 1
7	AMTC2	AM AGC time-constant capacitance 2
8	AMDET	Level detector input of AM-AGC
9	GND1	Ground AM
10	AMOUT	AM output, impedance matching
11	VS	Supply voltage
12	FMTC	FM AGC time constant
13	FMDET	Level detector input of FM-AGC
14	FMC	Collector of FM amplifier (NPN)
15	FMPD	FM AGC output for pin diode
16	FME	FM amplifier emitter(NPN)
17	FMB	FM amplifier base (NPN)
18	FMBIAS	Reference voltage 2.7V FM
19	GND2	Ground FM

Table 2-1. Pin Description (Continued)

Pin	Symbol	Function
20	AMPD	AM AGC output for pin diode
21	REF	Reference voltage 6V
22	AM LNA BIAS	Reference voltage for AM LNA IN
23	AM LNA IN	AM LNA input terminal
24	AM LNA SOURCE	AM LNA source terminal
25	CASCODE FILTER	AM Cascode filter terminal
26	AM LNA OUT	AM LNA output terminal
27	AMBIAS	Reference voltage for AMBUF IN
28	AMBUF IN	AM Buffer amplifier input, impedance matching
Paddle	GND	Ground paddle

3. Functional Description

The ATR4252 is a highly integrated AM/FM antenna IC with lots of features and functions. In fact the most important feature is the impedance matching on both the antenna input and the cable. The ATR4252 compensates cable losses between the antenna (for example, windscreen, roof or bumper antennas) and the car radio, which is usually placed far away from the antenna.

AM means long wave (LW), medium wave (MW) and short wave (SW) frequency bands (150 kHz to 30 MHz) that are usually used for AM as well as for DRM transmissions, and FM means any of the world wide used frequency bands for FM radio broadcast (70 MHz to 110 MHz).

Two separate amplifier chains are used for AM and FM due to the different operation frequencies and requirements in the AM and FM band. This allows the use of separate antennas (e.g., windscreen antennas) for AM and FM. Of course, both amplifier chain inputs can also be connected to one antenna (e.g., roof antenna).

The AM amplifier chain is separated into two amplifiers. The first one is an LNA that is optimized for low noise figure and low input capacitance. The second amplifier (AM buffer) is optimized to drive a possibly long antenna cable with high parasitic capacitance. Both amplifiers have outstanding large signal performance. All input and output terminals of these two amplifiers are accessible from outside so they can be connected together according to the application needs. Additionally, a filter can be inserted between LNA output and buffer amplifier input.

For AM and FM amplifier chain, two separate automatic gain control (AGC) circuits have been integrated in order to avoid overdriving the amplifiers in large signal conditions. The two separate AGC loops prevent strong AM signals from blocking FM stations and vice versa.

The integrated PIN diode drivers reduce the external component cost and board space.

A voltage regulation stage is integrated in order to further reduce the external component costs. This stage provides overvoltage protection and current limitation. An external transistor is used as power driver for this stage.

3.1 AM Amplifier

Due to the long wavelength in AM bands, the antennas used for AM reception in automotive applications are short compared to the wavelength. Therefore, these antennas do not provide 50Ω output impedance, but have an output impedance of some pF. If these (passive) antennas are connected to the car radio by a long cable, the capacitive load of this cable (some 100 pF) dramatically reduces the signal level at the tuner input.

In order to overcome this problem, ATR4252 provides two AM amplifiers, one LNA and one AM buffer amplifier. These two amplifiers can be used independently because all input/output terminals and bias inputs are externally accessible for the application.

The AM LNA has low input capacitance (12 pF typically) to reduce the capacitive load at the antenna and provides a voltage gain of typically 9 dB that can be varied from 0 to 15 dB depending on external application.

The AM buffer amplifier has a very low input capacitance of typically 2.45 pF and can also be connected directly to the car antenna if no additional gain is required. Due to the low output impedance of 8Ω , the buffer amplifier is perfectly suited to drive the capacitive load of long antenna cables. The voltage gain of this amplifier is close to 1 (0 dB), but the insertion gain that is achieved when the buffer amplifier is inserted between antenna output and antenna cable may be much higher (up to 35 dB). The actual value, of course, depends on antenna and cable capacitances.

The input of the buffer amplifier is connected by an external 4.7 M Ω resistor to the bias voltage in order to maintain high input impedance and low noise voltage.

AM tuners in car radios usually use PIN diode attenuators at their input. These PIN diode attenuators attenuate the signal by reducing the input impedance of the tuner. Therefore, a series resistor is used at the AM amplifier output in the standard application. This series resistor guarantees well-defined source impedance for the radio tuner and protects the output of the AM amplifier from short circuit by the PIN diode attenuator in the car radio.

3.2 AM AGC

The IC is equipped with an AM AGC capability to prevent overdriving of the amplifier in case the amplifier operates near strong signal sources, e.g., transmitters.

The AM amplifier output AMOUT is applied to a resistive voltage divider. This divided signal feeds the AGC level detector input pin AMDET. The rectified signal is compared against an internal reference. The threshold of the AGC can be adjusted by modification of the divider ratio of the external voltage divider. If the threshold is reached, the pin AMPD opens an internal transistor, which controls the pin diode current and limits the antenna signal to prevent an overdriving of the AM amplifier.

As the AM AGC has to react very slowly, large capacitors are usually needed for this time delay. To reduce the cost of the external components, a current control for the time delay is integrated, so that only small external capacitor values are needed.

The necessary driver for the external pin diode is already incorporated in the ATR4252 IC, which reduces the BOM cost and the application size.

3.3 FM Amplifier

The FM amplifier is realized with a high performance single NPN transistor. This allows the use of an amplifier configuration, which is optimized for the desired requirements. For low cost application, the common emitter configuration provides good performance at reasonable BOM cost. For high end application, common base configuration with lossless transformer feedback provides high IP3 and low noise figure at reasonable current consumption. In both configurations, gain, input and output impedance can be adjusted by modification of external components.

The temperature compensated bias voltage (FMBIAS) for the base of the NPN transistor is derived from an integrated voltage reference. The bias current of the FM amplifier is defined by an external resistor.

3.4 FM AGC

The IC is equipped with an AGC capability to prevent overdriving of the amplifier in case the amplifier is operated at strong antenna signals, e.g., near transmitters. It is possible to realize an additional antenna amplifier path with integrated AGC and external RF transistor. The bandwidth of the integrated AGC circuit is 900 MHz.

FM amplifier output FMC is connected to a capacitive voltage divider and the divided signal is applied to the AGC level detector at pin FMDDET. This level detector input is optimized for low distortion. The rectified signal is compared against an internal reference. The threshold of the AGC can be adjusted by tuning the divider ratio of the external voltage divider. If the threshold is reached, pin FMPD opens an internal transistor, which controls the pin-diode current. By these means, the amplifier input signal is limited and therefore the FM amplifier is prevented from signal overdrive.

The necessary driver for the external pin diode is already incorporated in the ATR4252 IC, which reduces the BOM cost and the application size.

3.5 Supply Voltage Regulator

The driving voltage for an external power transistor is provided by an integrated regulator circuit.

An overvoltage protection circuit recognizes overvoltage condition and switches off the amplifier and AGC circuits in order to reduce current consumption and avoid thermal overload.

3.6 Antenna Sensor

In addition, an antenna sensor has been integrated in order to recognize if the antenna is properly connected to the amplifier module. If no antenna is detected, the amplifier and AGC circuits are switched off in order to signal this error via reduction of supply current consumption to the unit that provides and monitors the supply current for the antenna amplifier (e.g., the car radio).

4. Absolute Maximum Ratings

Stresses beyond those listed under “Absolute Maximum Ratings” may cause permanent damage to the device. This is a stress rating only and functional operation of the device at these or any other conditions beyond those indicated in the operational sections of this specification is not implied. Exposure to absolute maximum rating conditions for extended periods may affect device reliability.

Reference point is ground.

Parameters	Pin	Symbol	Min.	Max.	Unit
Supply voltage	11	V_S	-0.3	+12	V
Collector of FM amplifier	14	FMC	3	16	V
AM LNA input terminal	23	AM LNA IN	0	2	V
AM LNA output terminal	26	AM LNA OUT	7	12	V
Power dissipation		P_{tot}		1200	mW
Junction temperature		T_j		150	°C
Ambient temperature		T_{amb}	-40	+105	°C
Storage temperature		T_{stg}	-50	+150	°C
ESD HBM	all	V_{HBM}	-2	+2	kV

5. Electrical Characteristics

Verified on test circuits (demo design made by Atmel), $V_S = 10\text{ V}$, $T_{\text{amb}} = 25^\circ\text{C}$, unless otherwise specified

No.	Parameters	Test Conditions	Pin	Symbol	Min.	Typ.	Max.	Unit
1.1	Supply current	AGC OFF	VS, FMC, AM LNA OUT	I_S		77		mA
		FMAGC ON	VS, FMC, AM LNA OUT	I_S		85	95	mA
		$T_{\text{amb}} = -40\text{ to }+105^\circ\text{C}$; FMAGC ON	VS, FMC, AM LNA OUT	I_S			99	mA
2	AM LNA+ Buffer⁽²⁾							
2.1	Input capacitance	$f = 1\text{ MHz}$	AM LNA IN	C_{AMLNAIN}		12		pF
2.4	Voltage gain	$f = 1\text{ MHz}$	AM/FM-OUT			9		dB
2.5	Input noise voltage	Buffer OUT, $R_{\text{BIAS}} = 4.7\text{ M}\Omega$, $B = 9\text{ kHz}$ $f = 1\text{ MHz}$	Antenna Dummy Input	V_N		-12		dB μV
2.7	Maximum operating frequency	3 dB corner	AM/FM-OUT		30			MHz
2.8	OIP3 ⁽¹⁾	AM/FM Out; $f_{\text{inp}} = 1\text{ MHz} + 1.1\text{ MHz}$, $V_{\text{out}} = 110\text{ dB}\mu\text{V}$, 1K 500 pF load, $V_S = 10\text{ V}$				144		dB μV
2.9	OIP2 ⁽¹⁾	AM/FM Out; $f_{\text{inp}} = 1\text{ MHz} + 1.1\text{ MHz}$, $V_{\text{out}} = 110\text{ dB}\mu\text{V}$, 1K 500 pF load, $V_S = 10\text{ V}$				170		dB μV
4	AM AGC							
4.1	Input resistance		AM DET	R_{AMDET}	40	50		k Ω
4.2	Input capacitance	$f = 1\text{ MHz}$	AM DET	C_{AMDET}	2.6	3.2	3.8	pF
4.4	3 dB corner frequency	AGC threshold increased by 3 dB	AM PD		30			MHz
4.5	Saturation voltage	10 mA	AM PD			$V_S - 1.9$		V
4.6	Leakage current		AM PD				4	μA
4.7	Maximum PIN Diode current	AGC active	AM PD		22	35		mA
5	FM Amplifier							
5.3	Supply current	Common base	FMC	I_{FMC}		29		mA
5.4	Supply current ⁽³⁾	Common emitter	FMC	I_{FMC}		35		mA
5.5	Maximum output voltage	$V_S = 10\text{ V}$	FMC		12			V_{pp}
5.6	Input resistance	$f = 100\text{ MHz}$	FM IN	R_{FMIN}		50		Ω
5.7	Maximum operating frequency	3 dB corner, common emitter	FM OUT		450			MHz
5.8	Output resistance	$f = 100\text{ MHz}$	FM OUT	R_{FMOUT}		50		Ω

Notes: 1. AGC Loop deactivated
2. Measured with antenna dummy.

5. Electrical Characteristics (Continued)

Verified on test circuits (demo design made by Atmel), $V_S = 10\text{ V}$, $T_{\text{amb}} = 25^\circ\text{C}$, unless otherwise specified

No.	Parameters	Test Conditions	Pin	Symbol	Min.	Typ.	Max.	Unit
5.9	Power gain	$f = 100\text{ MHz}$, common base circuit		G	5		8	dB
5.10	OIP3 at FMOUT	Common base circuit	FM OUT			145		$\text{dB}\mu\text{V}$
5.11	NF	Common base circuit				1.9		dB
5.12	Power gain	$f = 100\text{ MHz}$, common emitter circuit		G		13.5		dB
5.13	OIP3 at FMOUT	Common emitter circuit	FM OUT			140		$\text{dB}\mu\text{V}$
5.14	NF	Common emitter circuit	FM OUT			3.5		dB
6	FM AGC							
6.4	Maximum PIN Diode current	AGC active	FMPD		12	14		mA
6.5	Input resistance		FM DET	R_{FMDET}	17	21	25	$\text{k}\Omega$
6.6	Input capacitance	$f = 100\text{ MHz}$	FM DET	C_{FMDET}	1.5	1.75	2.0	pF
7	Voltage Regulator / Monitor							
7.1	Output voltage of regulator	Battery voltage $V_B = 14\text{V}$	VS		9.5	10	10.5	V
7.2	Ripple rejection of regulator	100 Hz, $V_B > V_S + 1\text{V}$	VB, AM/FM-Out		40	50		dB

- Notes:
1. AGC Loop deactivated
 2. Measured with antenna dummy.

6. Ordering Information

Extended Type Number	Package	Remarks
ATR4252-RAPW	VQFN 4x5 / 28L	Taped on reel, 1.5k volume
ATR4252-RAQW	VQFN 4x5 / 28L	Taped on reel, 6k volume

7. Package Information

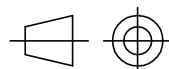
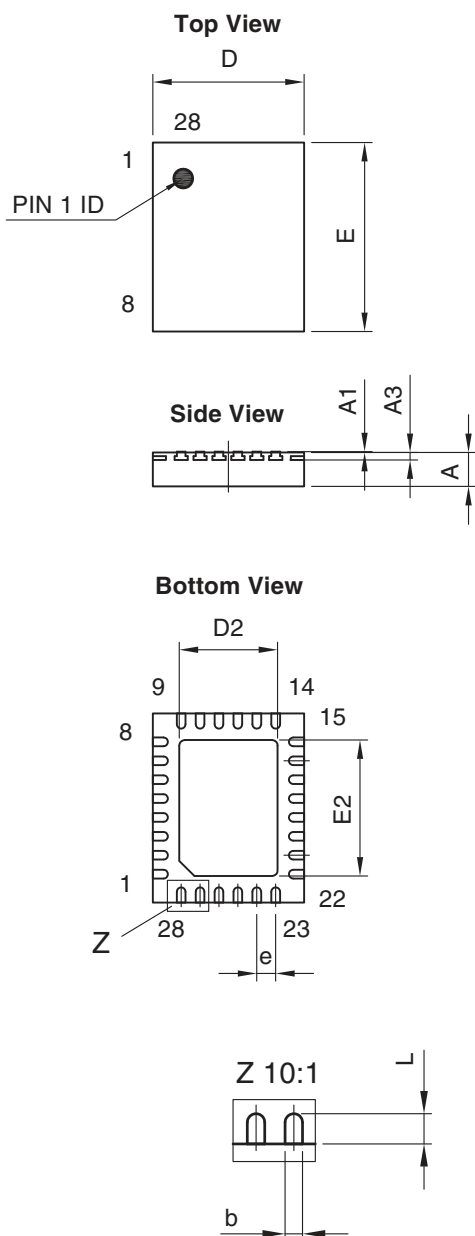

technical drawings
 according to DIN
 specifications

Dimensions in mm

COMMON DIMENSIONS				
(Unit of Measure = mm)				
Symbol	MIN	NOM	MAX	NOTE
A	0.8	0.9	1	
A1	0.0	0.02	0.05	
A3	0.15	0.2	0.25	
D	3.9	4	4.1	
D2	2.45	2.6	2.75	
E	4.9	5	5.1	
E2	3.45	3.6	3.75	
L	0.3	0.4	0.5	
b	0.16	0.23	0.3	
e		0.5 BSC		

06/18/08



Package Drawing Contact:
 packagedrawings@atmel.com

TITLE
 Package: VQFN_4x5_28L
 Exposed pad 2.6x3.6

DRAWING NO.
 6.543-5143.01-4

REV.
 2





Headquarters

Atmel Corporation
2325 Orchard Parkway
San Jose, CA 95131
USA
Tel: 1(408) 441-0311
Fax: 1(408) 487-2600

International

Atmel Asia
Unit 1-5 & 16, 19/F
BEA Tower, Millennium City 5
418 Kwun Tong Road
Kwun Tong, Kowloon
Hong Kong
Tel: (852) 2245-6100
Fax: (852) 2722-1369

Atmel Europe
Le Krebs
8, Rue Jean-Pierre Timbaud
BP 309
78054
Saint-Quentin-en-Yvelines Cedex
France
Tel: (33) 1-30-60-70-00
Fax: (33) 1-30-60-71-11

Atmel Japan
9F, Tonetsu Shinkawa Bldg.
1-24-8 Shinkawa
Chuo-ku, Tokyo 104-0033
Japan
Tel: (81) 3-3523-3551
Fax: (81) 3-3523-7581

Product Contact

Web Site
www.atmel.com

Technical Support
broadcast@atmel.com

Sales Contact
www.atmel.com/contacts

Literature Requests
www.atmel.com/literature

Disclaimer: The information in this document is provided in connection with Atmel products. No license, express or implied, by estoppel or otherwise, to any intellectual property right is granted by this document or in connection with the sale of Atmel products. **EXCEPT AS SET FORTH IN ATMEL'S TERMS AND CONDITIONS OF SALE LOCATED ON ATMEL'S WEB SITE, ATMEL ASSUMES NO LIABILITY WHATSOEVER AND DISCLAIMS ANY EXPRESS, IMPLIED OR STATUTORY WARRANTY RELATING TO ITS PRODUCTS INCLUDING, BUT NOT LIMITED TO, THE IMPLIED WARRANTY OF MERCHANTABILITY, FITNESS FOR A PARTICULAR PURPOSE, OR NON-INFRINGEMENT. IN NO EVENT SHALL ATMEL BE LIABLE FOR ANY DIRECT, INDIRECT, CONSEQUENTIAL, PUNITIVE, SPECIAL OR INCIDENTAL DAMAGES (INCLUDING, WITHOUT LIMITATION, DAMAGES FOR LOSS OF PROFITS, BUSINESS INTERRUPTION, OR LOSS OF INFORMATION) ARISING OUT OF THE USE OR INABILITY TO USE THIS DOCUMENT, EVEN IF ATMEL HAS BEEN ADVISED OF THE POSSIBILITY OF SUCH DAMAGES.** Atmel makes no representations or warranties with respect to the accuracy or completeness of the contents of this document and reserves the right to make changes to specifications and product descriptions at any time without notice. Atmel does not make any commitment to update the information contained herein. Unless specifically provided otherwise, Atmel products are not suitable for, and shall not be used in, automotive applications. Atmel's products are not intended, authorized, or warranted for use as components in applications intended to support or sustain life.

© 2009 Atmel Corporation. All rights reserved. Atmel®, logo and combinations thereof, and others are registered trademarks or trademarks of Atmel Corporation or its subsidiaries. Other terms and product names may be trademarks of others.