

RECOMMENDED MOUNTING HOLE PATTERN FOR .109±0.016 THICK P.C. BOARD

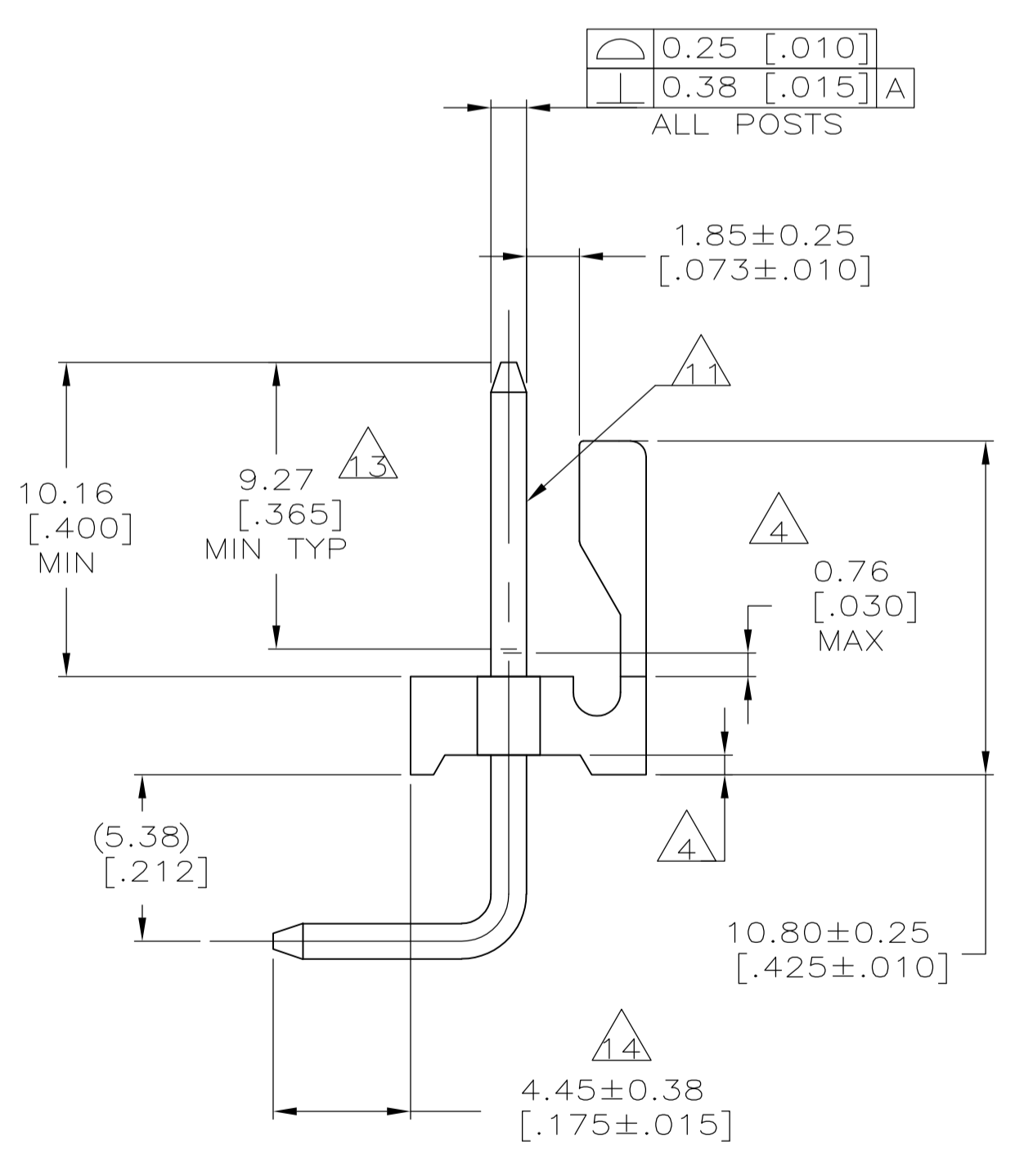
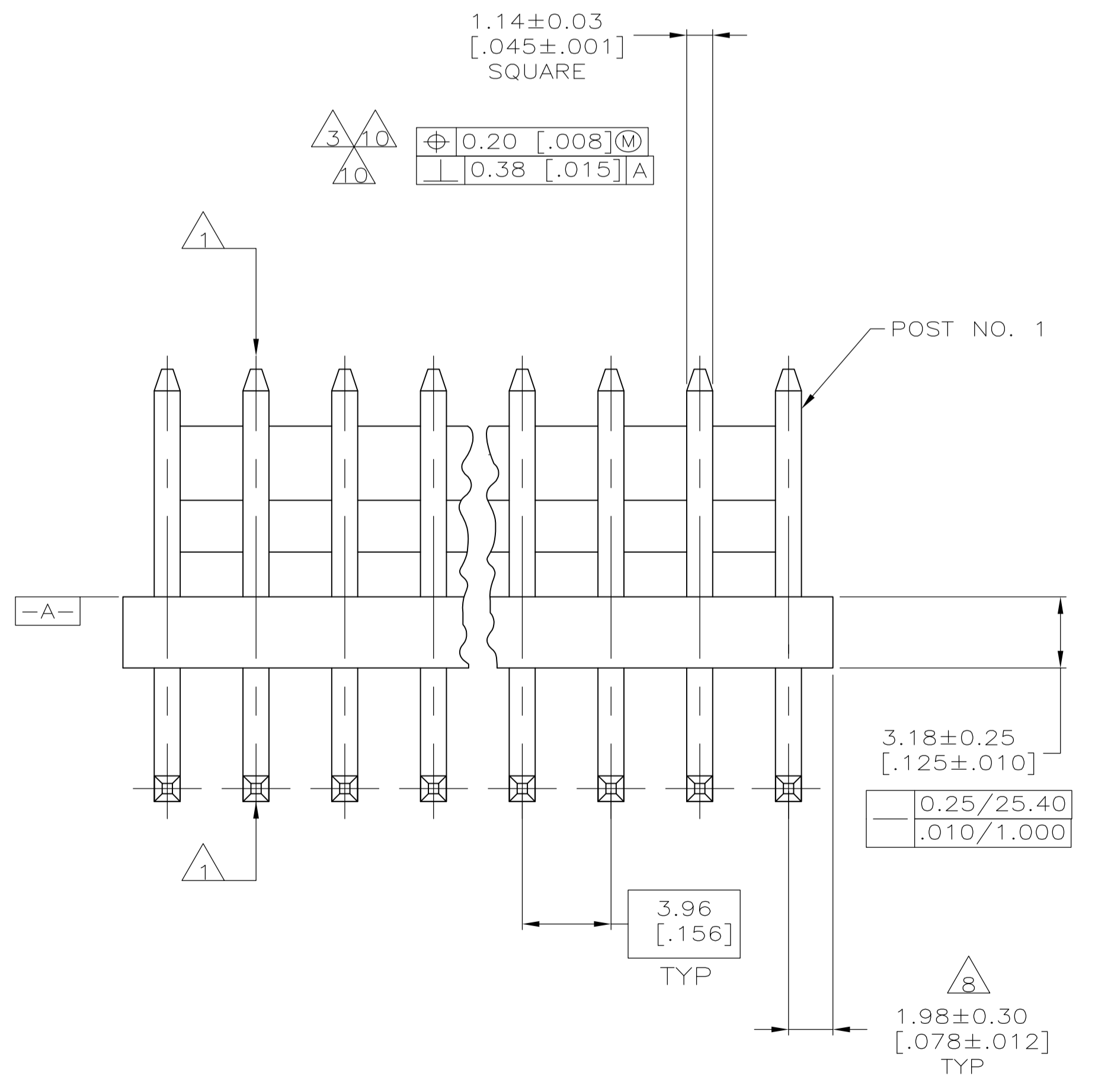
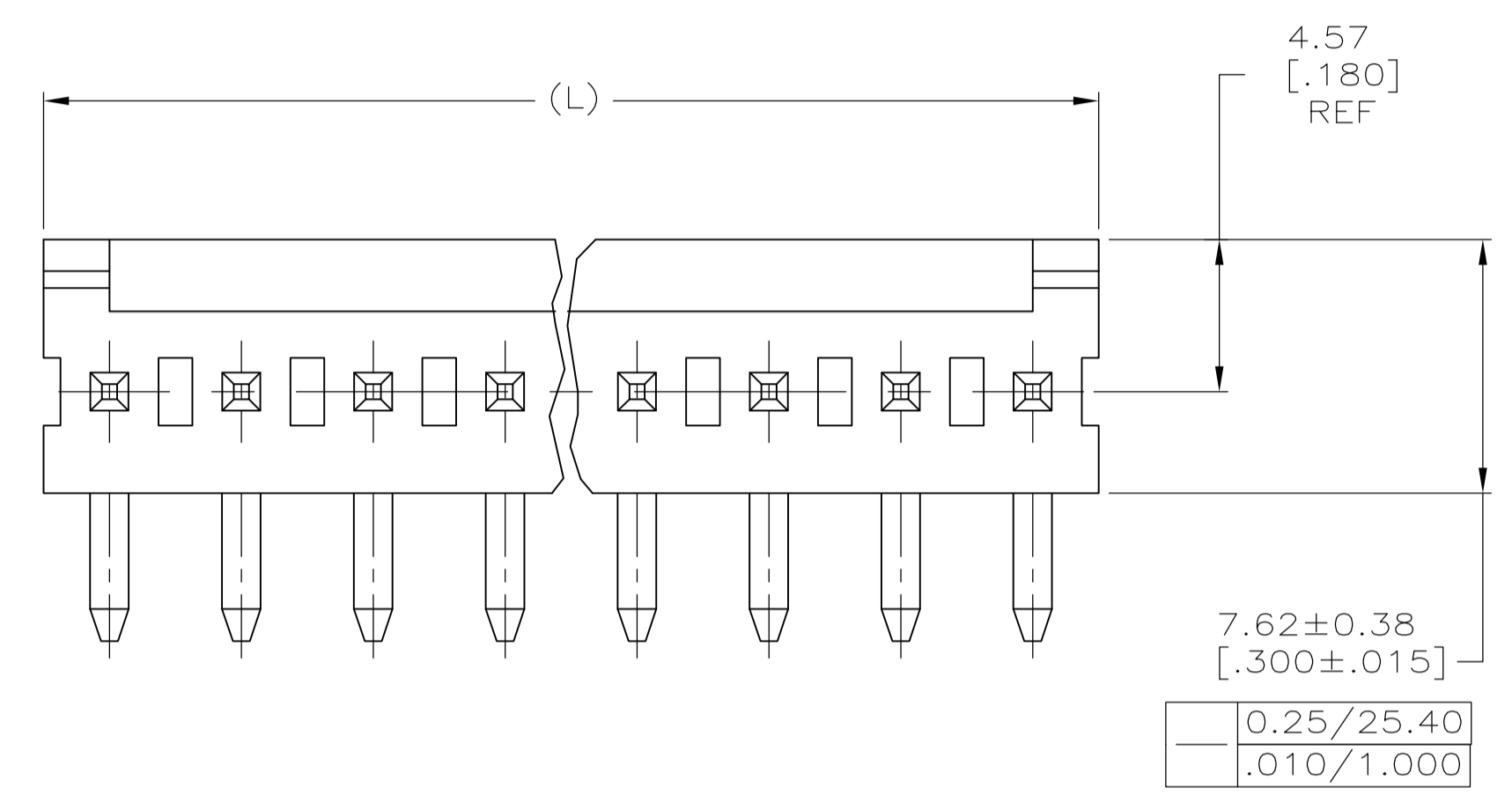

DIM (L)	NO. OF POSN	ASSEMBLY
95.10 [3.744]	24	5-644761-4
91.14 [3.588]	23	5-644761-3
87.17 [3.432]	22	5-644761-2
83.21 [3.276]	21	5-644761-1
79.25 [3.120]	20	5-644761-0
75.29 [2.964]	19	4-644761-9
71.32 [2.808]	18	4-644761-8
67.36 [2.652]	17	4-644761-7
63.40 [2.496]	16	4-644761-6
59.44 [2.340]	15	4-644761-5
55.47 [2.184]	14	4-644761-4
51.51 [2.028]	13	4-644761-3
47.55 [1.872]	12	4-644761-2
43.59 [1.716]	11	4-644761-1
39.62 [1.560]	10	4-644761-0
35.66 [1.404]	9	3-644761-9
31.70 [1.248]	8	3-644761-8
27.74 [1.092]	7	3-644761-7
23.77 [0.936]	6	3-644761-6
19.81 [0.780]	5	3-644761-5
15.85 [0.624]	4	3-644761-4
11.89 [0.468]	3	3-644761-3
7.92 [0.312]	2	3-644761-2

- 1 POST TO WITHSTAND 13 NEWTONS (3 LBS) MINIMUM AXIAL FORCE IN BOTH DIRECTIONS SHOWN WITHOUT DISLODGING.
- 2 TOLERANCES APPLY TO SOLDER SIDE OF BOARD.
- 3 MEASURED AT SURFACE -A-.
- 4 PLASTIC FLASH PERMITTED IN THIS AREA.
- 5 PARTS COMPLY WITH AMP SOLDERABILITY SPEC. NO. 109-11-2.
- 6 ONE HOLE MAY BE UNDERSIZED 1.65/1.52 [0.065/0.060] DIA. FOR ASSEMBLY RETENTION DURING WAVE SOLDERING.
- 7 MATERIAL: HEADER-THERMOPLASTIC POLYESTER GLASS-FILLED 94V-0 (NATURAL) POST-COPPER ALLOY (SEE NOTES 13 & 14 FOR PLATING)
- 8 COORDINATE DIMENSION APPLIES FROM CENTER OF ACTUAL FEATURE.
- 9 PLASTIC BURRS CAUSED BY CUT-OFF TOOLING ARE PERMITTED WITHIN THE MAXIMUM TOLERANCE ENVELOPE.
- 10 POST TO BE MEASURED WHEN STRIP IS HELD FLAT.
- 11 POST MUST WITHSTAND TWO 90° BENDS AGAINST EXTRUSION WITHOUT BREAKING.
- 12 DIMENSION SHOULD BE 8.26-10.16 [0.325-.400] MIN WHEN MATING WITH A MTA-156 CONNECTOR ASSEMBLY OR 8.26-8.76 [0.325-.345] MIN WHEN MATING WITH A SL-156 CONNECTOR ASSEMBLY.
- 13 PLATING: GOLD PLATE AREA, 0.00076 [0.000030] GOLD OR 0.00008 [0.000003] MIN GOLD FLASH OVER 0.00068 [0.000027] PALLADIUM NICKEL, PER TE CONNECTIVITY'S DISCRETION, ALL SIDES, OVER NICKEL UNDERPLATE, 0.00127 [0.000050] MIN, ALL SIDES AND ENTIRE LENGTH OF POST.
- 14 PLATING: BRIGHT TIN/LEAD (93/7) PLATE AREA, 0.00381-0.00889 [0.00150-.000350] THICK, ALL FOUR SIDES 4.45 [0.175] MINIMUM FOR -2 THRU -24. MATTE TIN PLATE AREA 0.00381-0.00889 [0.00150-.000350] THICK ALL FOUR SIDES, 4.45 [0.175] FOR -32 THRU -54.
- 15 OBSOLETE PARTS: OBSOLETE CIS STREAMLINING PER D.RENAUD/D.SINISI
- 16 OBSOLETE PART NUMBER

DIM (L)	NO. OF POSN	ASSEMBLY	LEAD	STAINLESS	STEEL	CO
95.10 [3.744]	24	5-644761-4	15	2-644761-4		
91.14 [3.588]	23	5-644761-3	15	2-644761-3		
87.17 [3.432]	22	5-644761-2	15	2-644761-2		
83.21 [3.276]	21	5-644761-1	15	2-644761-1		
79.25 [3.120]	20	5-644761-0	15	2-644761-0		
75.29 [2.964]	19	4-644761-9	15	1-644761-9		
71.32 [2.808]	18	4-644761-8	15	1-644761-8		
67.36 [2.652]	17	4-644761-7	15	1-644761-7		
63.40 [2.496]	16	4-644761-6	15	1-644761-6		
59.44 [2.340]	15	4-644761-5	15	1-644761-5		
55.47 [2.184]	14	4-644761-4	15	1-644761-4		
51.51 [2.028]	13	4-644761-3	15	1-644761-3		
47.55 [1.872]	12	4-644761-2	15	1-644761-2		
43.59 [1.716]	11	4-644761-1	15	1-644761-1		
39.62 [1.560]	10	4-644761-0	15	1-644761-0		
35.66 [1.404]	9	3-644761-9	15	644761-9		
31.70 [1.248]	8	3-644761-8	15	644761-8		
27.74 [1.092]	7	3-644761-7	15	644761-7		
23.77 [0.936]	6	3-644761-6	16	644761-6		
19.81 [0.780]	5	3-644761-5	15	644761-5		
15.85 [0.624]	4	3-644761-4	15	644761-4		
11.89 [0.468]	3	3-644761-3	15	644761-3		
7.92 [0.312]	2	3-644761-2	15	644761-2		

THIS DRAWING IS A CONTROLLED DOCUMENT.

DIMENSIONS: mm [INCHES]	TOLERANCES UNLESS OTHERWISE SPECIFIED:	DIN S. HOOVER 07NOV02	APVD D. ROSSI 07NOV02	NAME	MTA-156 HEADER ASSEMBLY, FRICTION LOCK, RIGHT ANGLE, FRONT BEND, .045 SQUARE POST, .000030 GOLD, SPECIAL
0 PLC ± -	1 PLC ± -	2 PLC ± 0.13[0.005]	3 PLC ± -	4 PLC ± -	ANGLES ± -
MATERIAL	FINISH	WEIGHT	SIZE	CAGE CODE	DRAWING NO
			A1	00779	644761
CUSTOMER DRAWING		SCALE	5:1	SHEET	1 OF 1
		REV	G2		

STE TE Connectivity