



ISL Products International

**Electronic Ballast for UV Bulbs
110 ~ 240VAC - "PS" Program Start
P.S-I-81338-A**

This electronic ballast is designed to operate different ultraviolet quartz germicidal lamps at 110~240VAC. It's equipped with push style terminals for seamless installation and has Intertek approvals, UL 935 standards.



Contact Us for alternative solutions!

Electrical Specifications					
Lamp Type:	GPH212T5	GPH287T5	GPH357T5	GPH436T5	
Input Voltage:	100 / 240VAC	100 / 240VAC	100 / 240VAC	100 / 240VAC	
Lamps Operated:	1 / 1	1 / 1	1 / 1	1 / 1	
Input Power (W):	16.19 / 17.96	20.40 / 22.44	25.01 / 25.71	29.27 / 28.81	
Line Current (A):	0.164 / 0.093	0.207 / 0.111	0.253 / 0.124	0.293 / 0.137	
Power Factor:	0.967 / 0.803	0.98 / 0.84	0.986 / 0.857	0.982 / 0.872	
THD:	15.6 / 35.6	11.3 / 13.8	7.2 / 12.2	6.9 / 10.4	
Lamp Voltage (V):	25	34	42	51	
Ballast Type:	Program Start (PS)		Lamp Current:	425mA (+/- 10%)	
Current Crest Factor:	< 1.7		Voltage Transients:	ANSI 62.41	

Environmental Specifications				
Sound Rating:	Class A		Min. Operating Temp:	0°C / 32°F
Weight:			Max. Case Temp:	70°C / 158°F

Protections				
Input Protection:	Fuse		Approvals:	UL.935 / CSA.C22.2
Output Protection:	EOL			Class "P"/1 Outdoor

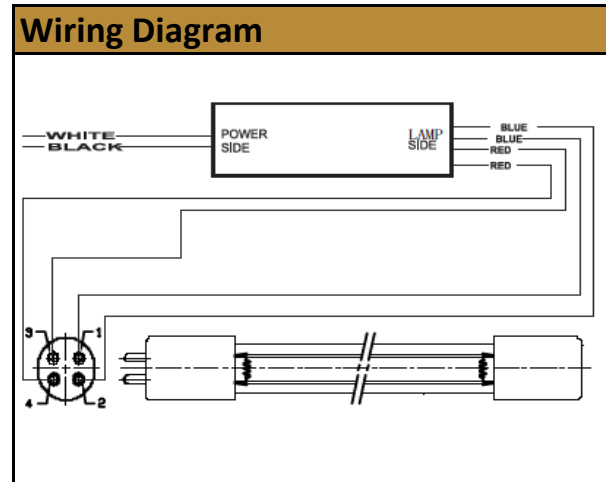
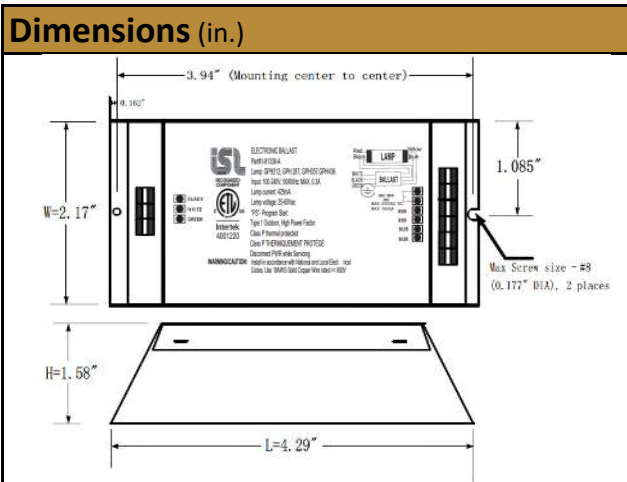

© 2021 ISL Products International Ltd. Specifications subject to change without notice.

