

PTE7100 SERIES

HERMETIC ANALOG PRESSURE SENSOR

The PTE7100 pressure sensor is the ideal solution for customers with challenging measuring requirements for general industrial applications in the mid and high pressure ranges. Utilizing Sensata's automotive leading Micro Silicon Strain Gauge with best-in-class accuracy, the PTE7100 features a wide range of ports, connectors, and analog electrical outputs for ease of integration in various industrial applications.

The PTE7100's high quality stainless steel design features a hermetic port with no internal o-ring seals making it compatible with most media and suitable for harsh environments. With extreme shock and vibration capabilities, a wide operating temperature range, and high proof and burst pressures; the PTE7100 is ideal for industrial applications including injection molding, CO₂ HVAC systems, and other hydraulic or pneumatic applications.



Features

- Measuring range from 0-50 bar to 0-600 bar (0-725 to 0-8700 psi)
- High accuracy
- Wide range of ports, connectors, and electrical outputs
- Stainless steel design with hermetic port
- Storage and operating media temperature -40-125°C; Operating ambient temp. range -40-100°C
- Snubber option for dampening of pressure spikes due to hammer and cavitation
- REACH/RoHS/CE compliant

Applications

- Hydraulics and Pneumatics
- Mobile Hydraulics and Off-Highway Vehicles
- Pumps and Compressors
- Air Conditioning and Refrigeration Systems
- Plant Engineering and Automation

SPECIFICATIONS

Electrical

Pressure Ranges	0-50 to 0-600 bar (0-725 to 0-8700 psi)
Pressure Reference	Gauge
Supply Voltage/Output	8-32VDC for 4-20mA output 5±0.25VDC for 0.5-4.5VDC output 8-32VDC for 0-5VDC output 12-32VDC for 0-10VDC output 8-32VDC for 1-5VDC output 8-32VDC for 0.5-4.5VDC output
Output Load	≥ 4.7 kΩ for voltage output ≤ (Vsup-8)/20mA for current supply
Output Response Time	<2 ms
Overvoltage Protection	36 VDC
Reverse Voltage Protection	Yes
Short Circuit Protection	Yes
Insulation Resistance	> 100 MΩ at 500V
EMC	IEC 61326-1 and EN 61326-2-3
Dielectric Strength	500 VAC
Enhanced Radiated Immunity	100V/m (80-200MHz) 200V/m (200-2700MHz)
Enhanced ESD	±8KV Contact; ±15KV Air

Physical

Proof Pressure	2X full scale pressure ⁽¹⁾
Burst Pressure	20X for full scale pressure = 50-100 bar 10X for full scale pressure = 101-400 bar 4000 bar for full scale pressure = 401-600 bar
Random Vibration	IEC 60068-2-6, 30g (10...2000Hz)
Mechanical Shock	EN 60068-2-27, 500g
Drop (any Axis)	1m
Ingress Protection	IP65 - IP67 (see Connector Options)
Media Compatibility	Fluids and Gases compatible with 17-4PH stainless steel

Performance

Accuracy (Best Fit Straight Line)⁽²⁾	±0.25%FS @25°C
Accuracy (Total Error Band)⁽³⁾	+/-1.5%FS @-20° to 85°C
Operating Endurance	>10M cycles
Operating Ambient Temperature	-40° to +100°C
Operating Media Temperature	-40° to +125°C
Storage Temperature	-40° to +125°C ⁽⁴⁾



DIMENSIONS

All dimensions are in millimeters

Pressure Port

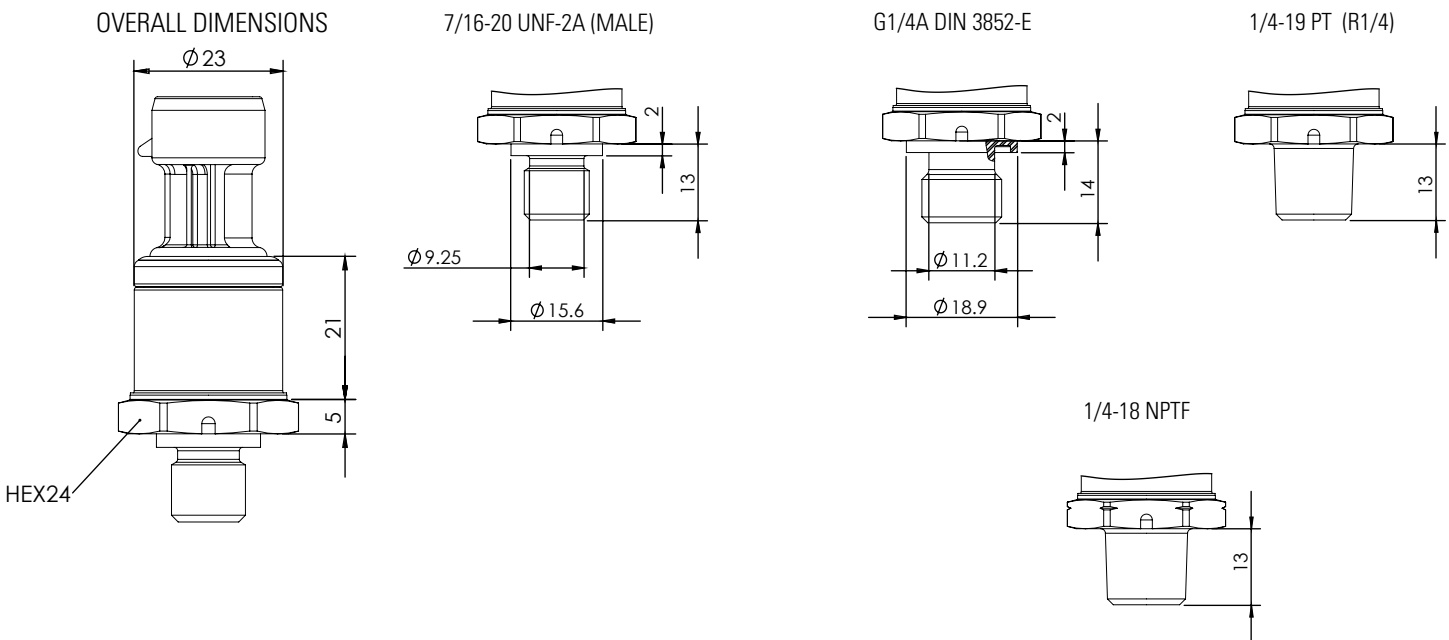

Electrical Connector

PACKARD METRI-PACK 150
IP67

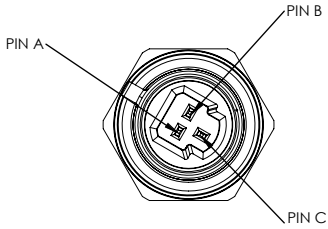
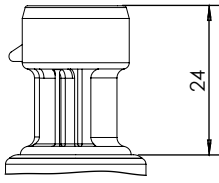

Output Type	PIN A	PIN B	PIN C
Voltage	V-	V+	Vout
Current	Iout	V+	...

M12x1 4-POLE
IP67

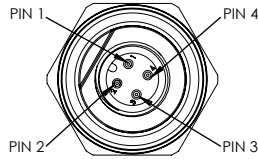
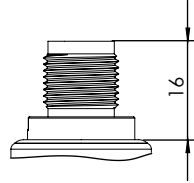

Output Type	PIN 1	PIN 2	PIN 3	PIN 4
Voltage	V+	...	V-	Vout
Current	V+	...	Iout	...

A: DIN 175301-803 FORM A(18mm)
IP65

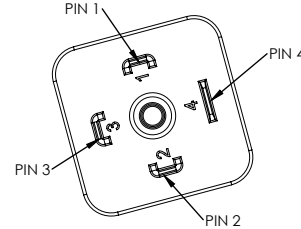
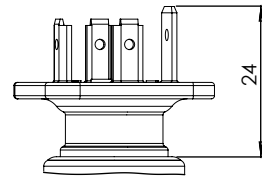

Output Type	PIN 1	PIN 2	PIN 3	PIN 4
Voltage	V+	V-	Vout	...
Current	V+	Iout

DEUTSCH DT04-3P
IP67

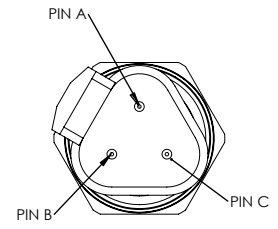
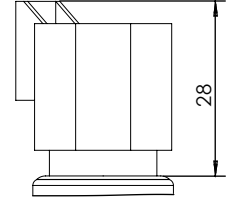

Output Type	PIN A	PIN B	PIN C
Voltage	V+	V-	Vout
Current	V+	Iout	...

FLY LEAD WITH HARNESS
IP67

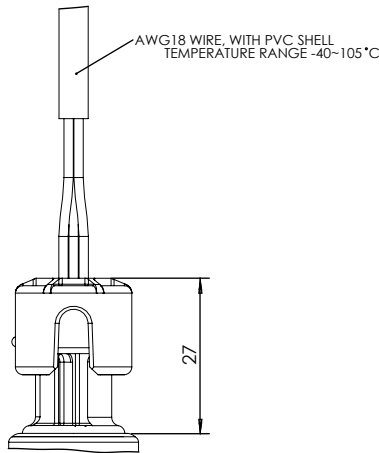

Output Type	RED	BLACK	WHITE
Voltage	V+	V-	Vout
Current	V+	Iout	...



ORDERING OPTIONS

Example : PTE7100-31AA-1A250BS

PTE7100 with G1/4A thread with external FKM o-ring seal, DIN A connector, 4-20

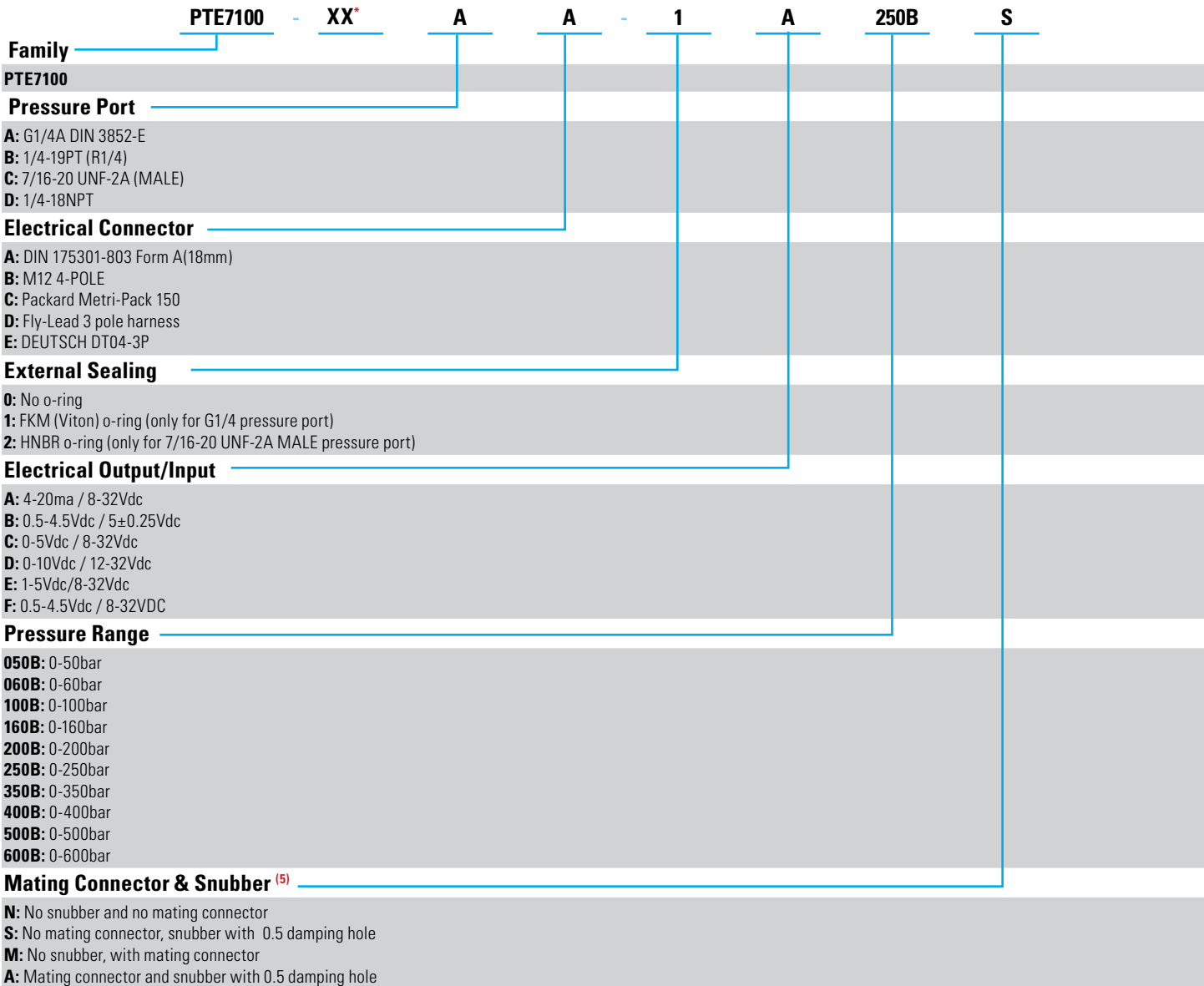

*Factory Specified



AGENCY APPROVALS & CERTIFICATIONS



GENERAL NOTES

- (1) Full Scale Pressure = Pmax - Pmin
- (2) Best fit straight line accuracy includes errors from non-linearity, non-repeatability, and hysteresis
- (3) Total error band accuracy includes errors from non-linearity, non-repeatability, hysteresis, zero offset, full span offset, and thermal effects
- (4) PVC flying leads are rated for storage of -40° to +105°C
- (5) Mating connector only available with DIN A connector

WARNINGS



RISK OF MATERIAL DAMAGE AND HOT ENCLOSURE

- The product's side panels may be hot, allow the product to cool before touching
- Follow proper mounting instructions including torque values
- Do not allow liquids or foreign objects to enter this product

Failure to follow these instructions can result in serious injury, or equipment damage.



HAZARD OF ELECTRIC SHOCK, EXPLOSION OR ARC FLASH

- Disconnect all power before installing or working with this equipment
- Verify all connections and replace all covers before turning on power

Failure to follow these instructions can result in death or serious injury.

Sensata Technologies, Inc. ("Sensata") data sheets are solely intended to assist designers ("Buyers") who are developing systems that incorporate Sensata products (also referred to herein as "components"). Buyer understands and agrees that Buyer remains responsible for using its independent analysis, evaluation and judgment in designing Buyer's systems and products. Sensata data sheets have been created using standard laboratory conditions and engineering practices. Sensata has not conducted any testing other than that specifically described in the published documentation for a particular data sheet. Sensata may make corrections, enhancements, improvements and other changes to its data sheets or components without notice.

Buyers are authorized to use Sensata data sheets with the Sensata component(s) identified in each particular data sheet. HOWEVER, NO OTHER LICENSE, EXPRESS OR IMPLIED, BY ESTOPPEL OR OTHERWISE TO ANY OTHER SENSATA INTELLECTUAL PROPERTY RIGHT, AND NO LICENSE TO ANY THIRD PARTY TECHNOLOGY OR INTELLECTUAL PROPERTY RIGHT, IS GRANTED HEREIN. SENSATA DATA SHEETS ARE PROVIDED "AS IS". SENSATA MAKES NO WARRANTIES OR REPRESENTATIONS WITH REGARD TO THE DATA SHEETS OR USE OF THE DATA SHEETS, EXPRESS, IMPLIED OR STATUTORY, INCLUDING ACCURACY OR COMPLETENESS. SENSATA DISCLAIMS ANY WARRANTY OF TITLE AND ANY IMPLIED WARRANTIES OF MERCHANTABILITY, FITNESS FOR A PARTICULAR PURPOSE, QUIET ENJOYMENT, QUIET POSSESSION, AND NON-INFRINGEMENT OF ANY THIRD PARTY INTELLECTUAL PROPERTY RIGHTS WITH REGARD TO SENSATA DATA SHEETS OR USE THEREOF.

All products are sold subject to Sensata's terms and conditions of sale supplied at www.sensata.com SENSATA ASSUMES NO LIABILITY FOR APPLICATIONS ASSISTANCE OR THE DESIGN OF BUYERS' PRODUCTS. BUYER ACKNOWLEDGES AND AGREES THAT IT IS SOLELY RESPONSIBLE FOR COMPLIANCE WITH ALL LEGAL, REGULATORY AND SAFETY-RELATED REQUIREMENTS CONCERNING ITS PRODUCTS, AND ANY USE OF SENSATA COMPONENTS IN ITS APPLICATIONS, NOTWITHSTANDING ANY APPLICATIONS-RELATED INFORMATION OR SUPPORT THAT MAY BE PROVIDED BY SENSATA.

Mailing Address: Sensata Technologies, Inc., 529 Pleasant Street, Attleboro, MA 02703, USA.

CONTACT US

Americas

+1 (800) 350 2727

sensors@sensata.com

switches@sensata.com

Europe, Middle East & Africa

+359 (2) 809 1826

pressure-info.eu@sensata.com

Asia Pacific

sales.isasia@list.sensata.com

China +86 (21) 2306 1500

Japan +81 (45) 277 7117

Korea +82 (31) 601 2004

India +91 (80) 67920890

Rest of Asia +886 (2) 27602006

ext 2808