

RoHS Compliant

512MB DDR SDRAM SO-DIMM **Industrial**

Product Specifications

December 3, 2013

Version 1.1



Apacer Technology Inc.

1F., No.32, Zhongcheng Rd., Tucheng Dist., New Taipei City 236, Taiwan

Tel: +886-2-2267-8000 Fax: +886-2-2267-2261

www.apacer.com

Table of Contents

General Description	2
Ordering Information	2
Key Parameters	2
Specifications:	3
Pin Assignments	4
Pin Descriptions	6
Functional Block Diagram	7
Absolute Maximum Ratings	8
DRAM Component Operating Temperature Range.....	9
Operating Conditions	10
Mechanical Drawing	11

General Description

Apacer **75.963AT.G020C** is 64M x 64 Double Data Rate SDRAM high density memory modules based on first generation of 512Mb DDR SDRAM respectively.

It consists of 8 pieces 64M x8 bit with 4banks Double Data Rate SDRAMs in 66pin TSOP-II (400mil) packages mounted on a 200pin glass-epoxy substrate. Decoupling capacitors are mounted on the printed circuit board in parallel for each DDR SDRAM. This product is Dual In-line Memory Modules and intended for mounting into 200 pin edge connector sockets.

Synchronous design allows precise cycle control with the use of system clock. Data I/O transactions are possible on both edges of DQS. Range of operating frequencies, programmable latencies and burst lengths allow the same device to be useful for a variety of high bandwidth, high performance memory system applications.

Ordering Information

Part Number	Bandwidth	Speed Grade	Max Frequency	CAS Latency
75.963AT.G020C	3.2 GB/sec	400 Mbps	200 MHz	CL3

Density	Organization	Component	Rank
512MB	64M x 64	64M x8*8	1

Key Parameters

MT/s	DDR-266	DDR-266	DDR-333	DDR-400	Unit
Grade	-CL2	-CL2.5	-CL2.5	-CL3	
tCK (min)	7.5	7.5	6	5	ns
CAS latency	2	2.5	2.5	3	tCK
tRC	9	9	10	11	tCK
tRAS	6	6	7	8	tCK
CL-tRCD-tRP	2-3-3	2.5-3-3	2.5-3-3	3-3-3	tCK

Specifications:

- ◆ Power supply V_{DD} : 2.6V +/-0.1V
- ◆ MRS cycle with address key programs
- ◆ CAS Latency (Access from column address): 2.5, 3
- ◆ Burst length : 2, 4, 8
- ◆ Data scramble ;Sequential & Interleave
- ◆ Serial presence detect with EEPROM
- ◆ SSTL-2 interface
- ◆ Differential clock input
- ◆ Compliance With RoHS
- ◆ Compliance With CE
- ◆ Auto Refresh and self Refresh Modes 64ms, 8192-cycle refresh
- ◆ Operating Temperature Rang : Industrial $-40^{\circ}\text{C} \leq T_A \leq 85^{\circ}\text{C}$

Pin Assignments

Pin No.	Pin name	Pin No.	Pin name	Pin No.	Pin name	Pin No.	Pin name
1	VREF	51	Vss	101	A9	151	DQ42
3	Vss	53	DQ19	103	Vss	153	DQ43
5	DQ0	55	DQ24	105	A7	155	VDD
7	DQ1	57	VDD	107	A5	157	VDD
9	VDD	59	DQ25	109	A3	159	Vss
11	DQS0	61	DQS3	111	A1	161	Vss
13	DQ2	63	Vss	113	VDD	163	DQ48
15	Vss	65	DQ26	115	A10/AP	165	DQ49
17	DQ3	67	DQ27	117	BA0	167	VDD
19	DQ8	69	VDD	119	\overline{WE}	169	DQS6
21	VDD	71	CB0	121	$\overline{CS0}$	171	DQ50
23	DQ9	73	CB1	123	NC	173	Vss
25	DQS1	75	Vss	125	Vss	175	DQ51
27	Vss	77	DQS8	127	DQ32	177	DQ56
29	DQ10	79	CB2	129	DQ33	179	VDD
31	DQ11	81	VDD	131	VDD	181	DQ57
33	VDD	83	CB3	133	DQS4	183	DQS7
35	CK0	85	NC	135	DQ34	185	Vss
37	$\overline{CK0}$	87	Vss	137	Vss	187	DQ58
39	Vss	89	CK2	139	DQ35	189	DQ59
41	DQ16	91	$\overline{CK2}$	141	DQ40	191	VDD
43	DQ17	93	VDD	143	VDD	193	SDA
45	VDD	95	CKE1	145	DQ41	195	SCL
47	DQS2	97	NC	147	DQS5	197	VDDSPD
49	DQ18	99	A12	149	Vss	199	VDDID

Pin No.	Pin name	Pin No.	Pin name	Pin No.	Pin name	Pin No.	Pin name
2	VREF	52	Vss	102	A8	152	DQ46
4	Vss	54	DQ23	104	Vss	154	DQ47
6	DQ4	56	DQ28	106	A6	156	VDD
8	DQ5	58	VDD	108	A4	158	$\overline{\text{CK1}}$
10	VDD	60	DQ29	110	A2	160	CK1
12	DM0	62	DM3	112	A0	162	Vss
14	DQ6	64	Vss	114	VDD	164	DQ52
16	Vss	66	DQ30	116	BA1	166	DQ53
18	DQ7	68	DQ31	118	$\overline{\text{RAS}}$	168	VDD
20	DQ12	70	VDD	120	$\overline{\text{CAS}}$	170	DM6
22	VDD	72	CB4	122	$\overline{\text{CS1}}$	172	DQ54
24	DQ13	74	CB5	124	NC	174	Vss
26	DM1	76	Vss	126	Vss	176	DQ55
28	Vss	78	DM8	128	DQ36	178	DQ60
30	DQ14	80	CB6	130	DQ37	180	VDD
32	DQ15	82	VDD	132	VDD	182	DQ61
34	VDD	84	CB7	134	DM4	184	DM7
36	VDD	86	NC	136	DQ38	186	Vss
38	Vss	88	Vss	138	Vss	188	DQ62
40	Vss	90	Vss	140	DQ39	190	DQ63
42	DQ20	92	VDD	142	DQ44	192	VDD
44	DQ21	94	VDD	144	VDD	194	SA0
46	VDD	96	CKE0	146	DQ45	196	SA1
48	DM2	98	NC	148	DM5	198	SA2
50	DQ22	100	A11	150	Vss	200	NC

Notes:

1. Pins 71, 72, 73, 74, 77, 78, 79, 80, 83, 84 are not used on x64 module, & used on x72 module.

Pin Descriptions

Pin Name	Description
Ax	SDRAM address bus
BAx	SDRAM bank select
$\overline{\text{RAS}}$	SDRAM row address strobe
$\overline{\text{CAS}}$	SDRAM column address strobe
$\overline{\text{WE}}$	SDRAM write enable
$\overline{\text{CSx}}$	DIMM Rank Select Lines
CKEx	SDRAM clock enable lines
DQx	DIMM memory data bus
DQSx	SDRAM data strobes(positive line of differential pair)
DMx	SDRAM data masks high data strobes(x8-based X72 DIMMs)
CKx	SDRAM clocks(positive line of differential pair)
$\overline{\text{CKx}}$	SDRAM clocks(negative line of differential pair)
SCL	I2C serial bus clock for EEPROM
SDA	I2C serial bus data line for EEPROM
SAX	I2C slave address select for EEPROM
VDD	SDRAM core power supply
VDDQ	SDRAM I/O Driver power supply
VREF	SDRAM I/O reference supply
VSS	Power supply return(ground)
VDDSPD	Serial EEPROM positive power supply
VDDID	VDD identification flag
NC	Spare pins(no connect)

Functional Block Diagram

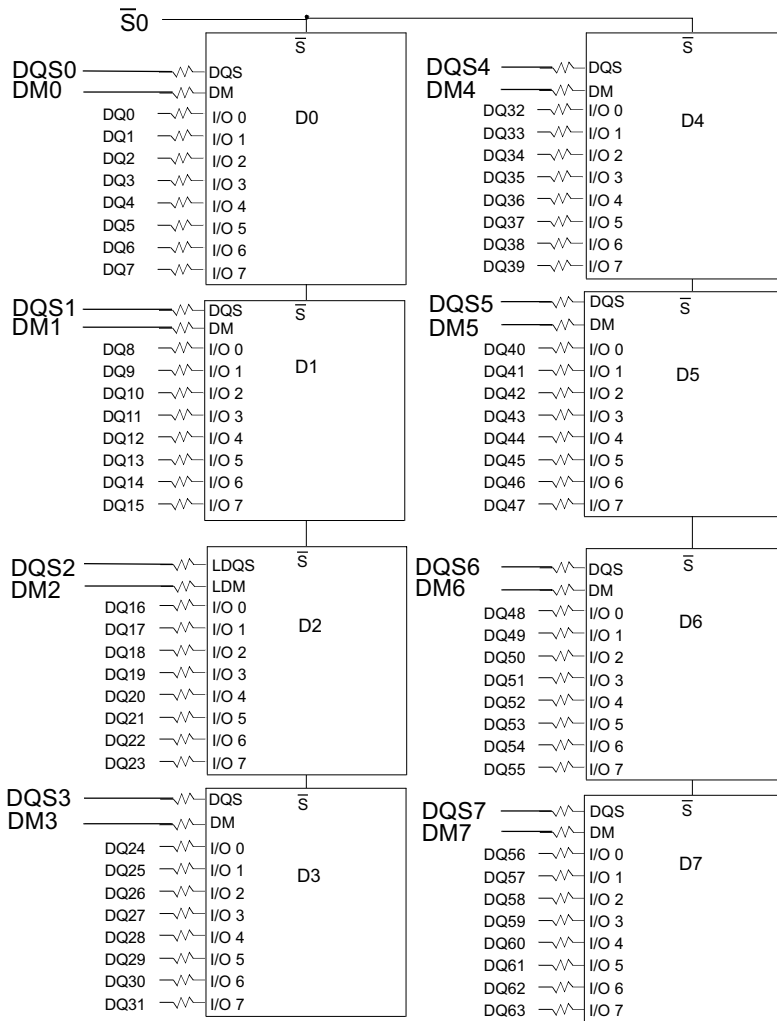

#Unless otherwise noted, resistor values are $22 \Omega \pm 5\%$

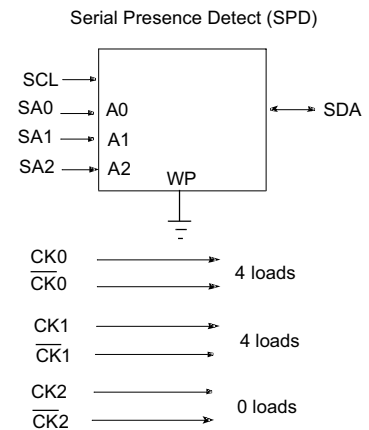
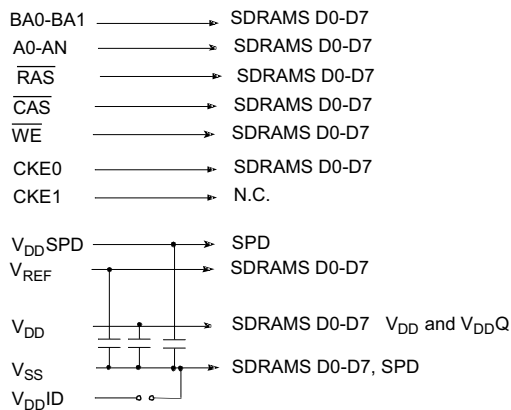

Note: DQ wiring may differ from that described in this drawing; however DQ/DM/DQS relationships are maintained as shown.
V_{DD}ID strap connections:
(for memory device V_{DD}, V_{DD}Q)
Strap out (open): V_{DD} = V_{DD}Q
Strap in (closed): V_{DD} ≠ V_{DD}Q

Absolute Maximum Ratings

Parameter	Symbol	Description	Units
Supply Voltage Relative to VSS	V _{DD}	- 1.0 V ~ 3.6 V	V
Supply Voltage Relative to VSS	V _{DDQ}	- 1.0 V ~ 3.6 V	V
VREF and Inputs Voltage Relative to VSS	V _{IN} , V _{OUT}	- 0.5 V ~ 3.6 V	V
Storage Temperature	TSTG	-55 to +100	°C

Notes:

Stresses above those listed under “Absolute Maximum Ratings” may cause permanent damage of the device.

Exposure to absolute maximum rating conditions for extended periods may affect device reliability. .

DRAM Component Operating Temperature Range

Symbol	Parameter	Rating	Units	Notes
TA	Operating Temperature Rang: Industrial	-40 to 85	°C	

Operating Conditions

Recommended DC Operating Conditions - DDR (2.6V ± 0.1V) operation

Symbol	Parameter	Rating			Units
		Min.	Typ.	Max.	
VDD	Supply Voltage	2.5	2.6	2.7	V
VDDQ	Supply Voltage for Output	2.5	2.6	2.7	V

Notes:

1. VREF is expected to be equal to 0.5 x VDDQ of the transmitting device, and to track variations in the DC level of the same. Peak-to-peak noise on VREF may not exceed 2% of the DC value
2. VTT is not applied directly to the device. VTT is a system supply for signal termination resistors, is expected to be set equal to VREF, and must track variations in the DC level of VREF
3. VID is the magnitude of the difference between the input level on CK and the input level on /CK.

Mechanical Drawing

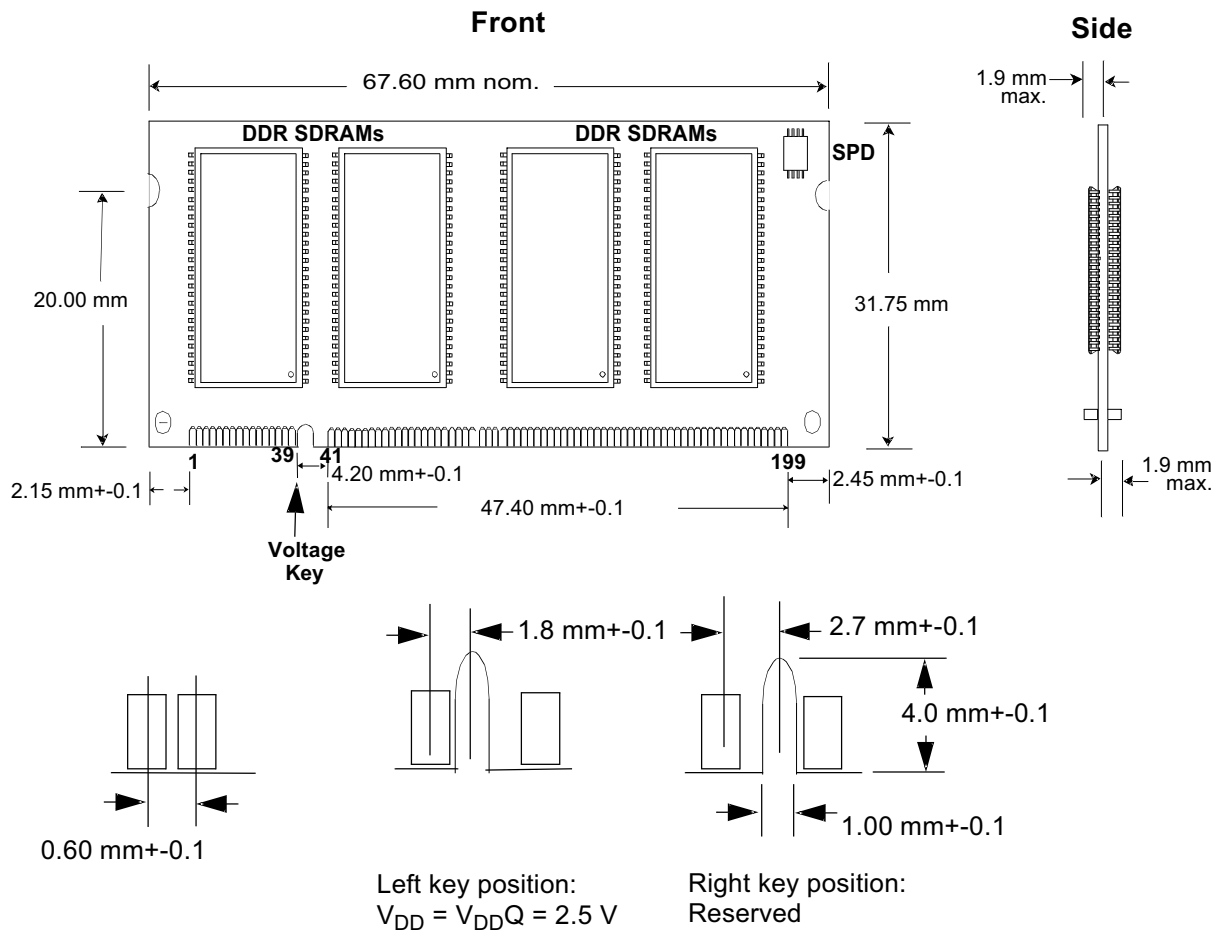

TOLERANCES ON ALL DIMENSIONS \pm 0.13 UNLESS OTHERWISE SPECIFIED.

Revision History

Revision	Date	Description	Remark
0.9	08/28/2012	Official release	
1.0	08/29/2012	release	
1.1	07/23/2013	Changed headquarters address	

Global Presence

Taiwan (Headquarters)

Apacer Technology Inc.

1F., No.32, Zhongcheng Rd., Tucheng Dist.,

New Taipei City 236, Taiwan R.O.C.

Tel: +886-2-2267-8000

Fax: +886-2-2267-2261

amtsales@apacer.com

U.S.A.

Apacer Memory America, Inc.

386 Fairview Way, Suite102,

Milpitas, CA 95035

Tel: 1-408-518-8699

Fax: 1-408-935-9611

sa@apacerus.com

Japan

Apacer Technology Corp.

5F, Matsura Bldg., Shiba, Minato-Ku

Tokyo, 105-0014, Japan

Tel: 81-3-5419-2668

Fax: 81-3-5419-0018

jpservices@apacer.com

Europe

Apacer Technology B.V.

Science Park Eindhoven 5051 5692 EB Son,

The Netherlands

Tel: 31-40-267-0000

Fax: 31-40-267-0000#6199

sales@apacer.nl

China

Apacer Electronic (Shanghai) Co., Ltd

1301, No.251,Xiaomujiao Road, Shanghai,

200032, China

Tel: 86-21-5529-0222

Fax: 86-21-5206-6939

sales@apacer.com.cn

India

Apacer Technologies Pvt Ltd,

535, 1st Floor, 8th cross, JP Nagar 3rd Phase,

Bangalore – 560078, India

Tel: 91-80-4152-9061

sales_india@apacer.com