

5 & 8 Port, Ultra Compact Industrial Ethernet Switches

ESW105 & ESW108 Series



PRODUCT FEATURES

- Ultra compact design - less than 1 inch wide
- UL/cUL Class I/Division 2 Groups A,B,C, and D
- Designed to meet Level 3 (Heavy) industrial environments - EN61000-6-2 Certifications
- Shock, vibration, free fall tested
- LC single and multi mode fiber ports
- 10/100M, full/half duplex, MDI/MDI-X (Auto-negotiate)
- Supports IEEE 802.3, 802.3u, and 802.3x standards
- IP30 rated DIN rail case with 6 different panel mount options
- Dual power inputs, 12 to 36 VDC and 10 to 24 VAC
- 2K MAC addresses

Designed to fit many applications, the ESW105 and ESW108 series are more than just an Ethernet switch with low pricing. They are plug-and-play industrial Ethernet Switches with an ultra compact IP30 DIN rail case, 6 way mountable panel brackets, LEDs for Power, (Link / Speed / Activity for each port), 12 to 36 VDC and 10 to 24 VAC power inputs with removable terminal blocks. These switches are perfect for any applications that require special protection from harsh environments.

Choose a switch with five or eight copper ports, or a combination of copper and fiber ports. Multi-mode fiber models extend range up to 2 km. Single-mode fiber models extend range up to 20 km. All models require an external power supply (sold separately).

The switch ships with 4 panel mount clips giving the user 6 different ways to panel mount the unit.

ORDERING INFORMATION

MODEL NUMBER	10/100 COPPER	MULTI-MODE FIBER	SINGLE-MODE FIBER
ESW105	5		
ESW105-ML	4	1 (LC)	
ESW105-SL	4		1 (LC)
ESW108	8		
ESW108-ML	7	1 (LC)	
ESW108-SL	7		1 (LC)

ACCESSORIES

- DFMM-LCLC-3M - Multi-Mode Duplex Fiber Cable, LC to LC, 3 Meter
- MDR-20-24 - DIN rail mount power supply 24VDC, 1.0 A output power
- MDR-40-24 - DIN rail mount power supply 24VDC, 1.7 A output power
- EIRSP1 - Industrial DIN rail mount Ethernet Surge Suppressor

5 & 8 Port, Ultra Compact Industrial Ethernet Switches

ESW105 & ESW108 Series



SPECIFICATIONS

TECHNOLOGY	
Standards:	IEEE802.3, 802.3u, 802.3x
Processing Type:	Store and forward with IEEE802.3x full duplex, non-blocking flow control
Flow Control:	IEEE802.3x flow control, back pressure flow control
Packet Buffer Memory:	64K bytes
Address Table Size	2K MAC Addresses
INTERFACE	
RJ45 Ports:	10/100BaseT(X) auto negation, Full/Half duplex, auto MDI/MD-X
Fiber Ports:	100BaseFX, (multi-mode or single-mode with LC connectors)
LED Indicators:	Power, (Link / Speed / Activity for each port)
POWER	
Input Voltage	12 to 36 VDC and 10 to 24 VAC
Power Consumption	4.00 W Max
Input Connection	Removable Terminal Block
Protection	Reverse Polarity Protection
ENVIRONMENTAL	
Operating Temperature	-10 to 60°C (14 to 140°F)
Storage Temperature	-40 to 80°C (-40 to 176°F)
Humidity	10 to 95% Non-condensing
MTBF	200,000 hours
MTBF Calculation	Parts count reliability prediction
MECHANICAL	
Enclosure	IP30 DIN mount metal case
Dimensions (5 ports)	H 10.0 x W 2.5 x D 7.5 mm (3.94 x 0.98 x 2.95in)
Dimensions (8 ports)	H 145 x W 24 x D 75mm (5.71 X 0.94 x 2.95in)
Installation	35 mm DIN or 6 way panel mount

FIBER OPTICS				
Fiber Type	Distance	Wavelength	Transmit Power	Receive Sensitivity
Multi-mode	2 km	1310 nm	- 23.5 to - 14 dBm	≤ - 35 dBm
Single-mode	20 km	1310 nm	- 15 to - 8 dBm	≤ - 35 dBm

REGULATORY APPROVALS	
CE, FCC, RoHS	
HAZARDOUS LOCATIONS	
UL/cUL Class I Div 2 Groups A,B,C, and D	

SPECIFICATIONS—LEVEL 3, EN 61000-6-2: 2006 GENERIC STANDARDS FOR (HEAVY) INDUSTRIAL ENVIRONMENTS

Test	Description	Test Level	Level
EN 55022: 2006 + A1:2007	Class B Emissions		
EN 61000-4-2: 2009	Electro-Static Discharge (ESD)	Enclosure Contact 6kV	3
		Enclosure Air 8kV	3
EN61000-4-3:2006+A1:2008	Radiated Field Immunity (RFI)	Enclosure Ports 10V/m	3
		Signal Ports 1kV	3
EN61000-4-4:2004	Burst (Fast Transient)	DC Ports 2kV	3
		Signal Ports 1kV	3
EN61000-4-5:2006	Surge	DC Power 2kV	3
		Ports 10 V RMS	3
EN61000-4-6: 2009	Induced (Conductive) RFI	Signal Ports 10 V RMS	3
		DC Power 10 V RMS	3

ENVIRONMENTAL SPECIFICATIONS

TEST	DESCRIPTION	TEST LEVEL	LEVEL
IEC60068-2-6	Vibration	Test Fc	2G
IEC60068-2-27	Shock	Test Ea	30G
IEC 60068-2-32	Free Fall		-----

MECHANICAL DIAGRAM 5 PORT MODEL

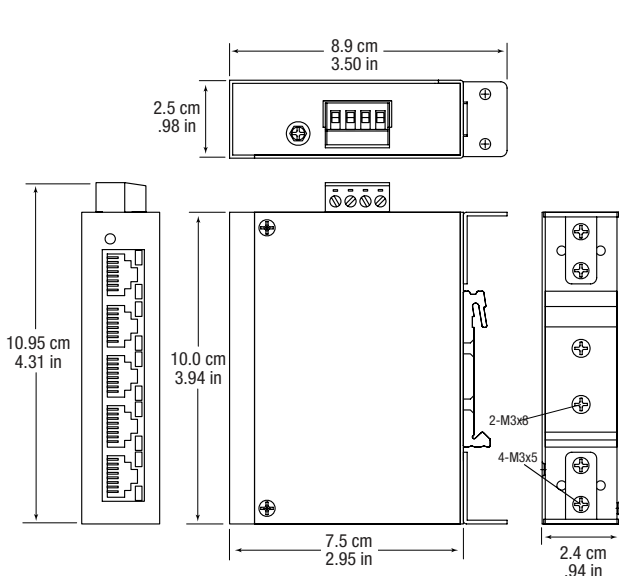

MECHANICAL DIAGRAM 8 PORT MODEL

