

REV.	ECR/ECN No.	DESCRIPTION	DRAWN/DATE	CHECKED/DATE	APPROVED/DATE
A		NEW RELEASE	Staven 2019-03-04	Peng Li 2019-03-04	Judy 2019-03-04
B	ECN2022152	UPDATE FRAME	Abner 2022-09-28	Staven 2022-09-28	Sam 2022-09-28

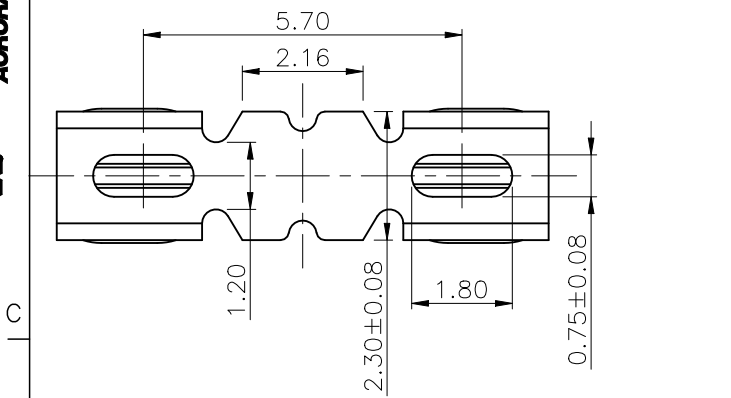

NOTES:

1. MATERIAL: STAINLESS;
2. FINISH: GOLD FLASH SURFACE PLATING OVER SOLDER AREA, Ni 40-120u" UNDER PLATING OVER ALL.
3. ALL MATERIAL MUST BE COMPLY WITH RoHS2.0;
4. WITH "▼" MUST BE CPK CONTROL.

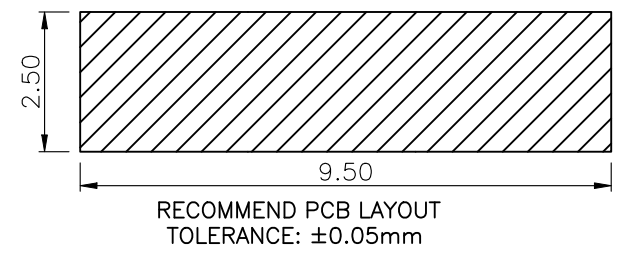
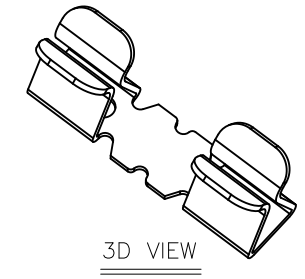
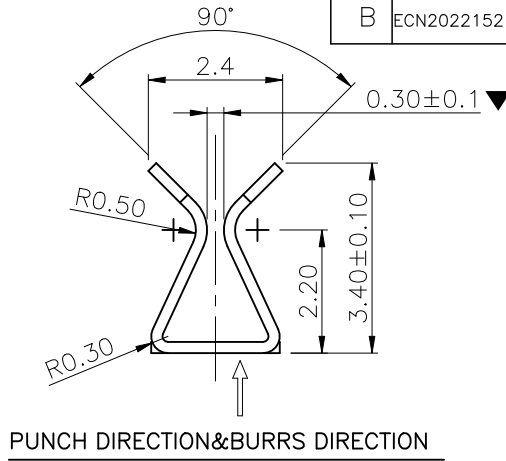
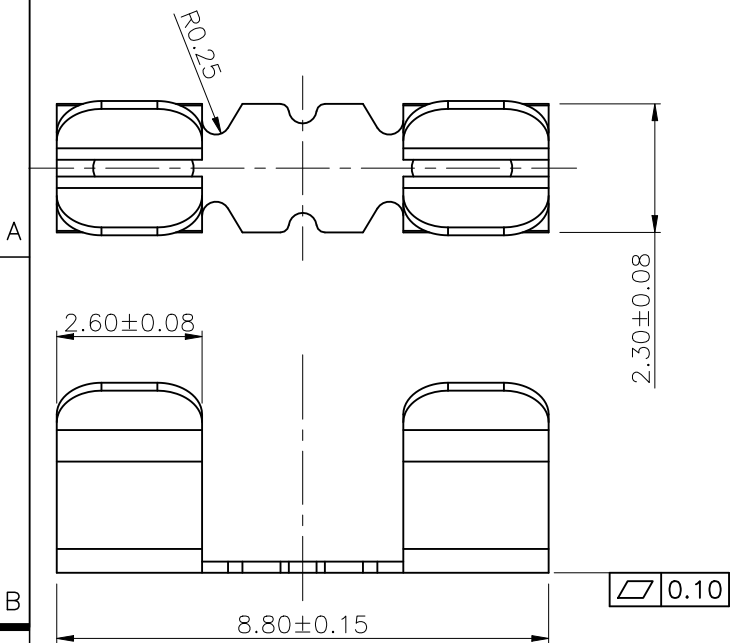

This document is the property of and embodies CONFIDENTIAL and PROPRIETARY information of AOR. No part of the information shown on this document may be used in any way or disclosed to others without the written consent of AOR. © 2019 AOR

UNLESS OTHERWISE SPECIFIED TOLERANCES			ANGLE OF PROJECTION		Amphenol AORORA		
X.	±0.30	X. °	± 5'		Amphenol Aorora Technology (Huizhou) Co.,Ltd		
X.X	±0.25	X.X °	± 4'				
X.XX	±0.20	X.XX °	± 3'	DOC TYPE	Assembly Draw		
X.XXX	±0.15	X.XXX °	± 2'	DRAWN DATE	Staven	TITLE:	
LINEAR DIMS			ANGLES DIMS	DESIGN DATE	Staven	H3.4 CLIP	
DWG NO.: A-S0530				CHECKED DATE	Peng Li	SIZE	PART NUMBER:
MATERIAL	SEE NOTES			APPROVED DATE	Judy	A4	Z017-4G7C1-11000-E200
FINISHED	SEE NOTES					SCALE	1:1
						UNIT	mm
						SHEET	1 OF 1
						REV.	B

1. PACKING INTO REEL:

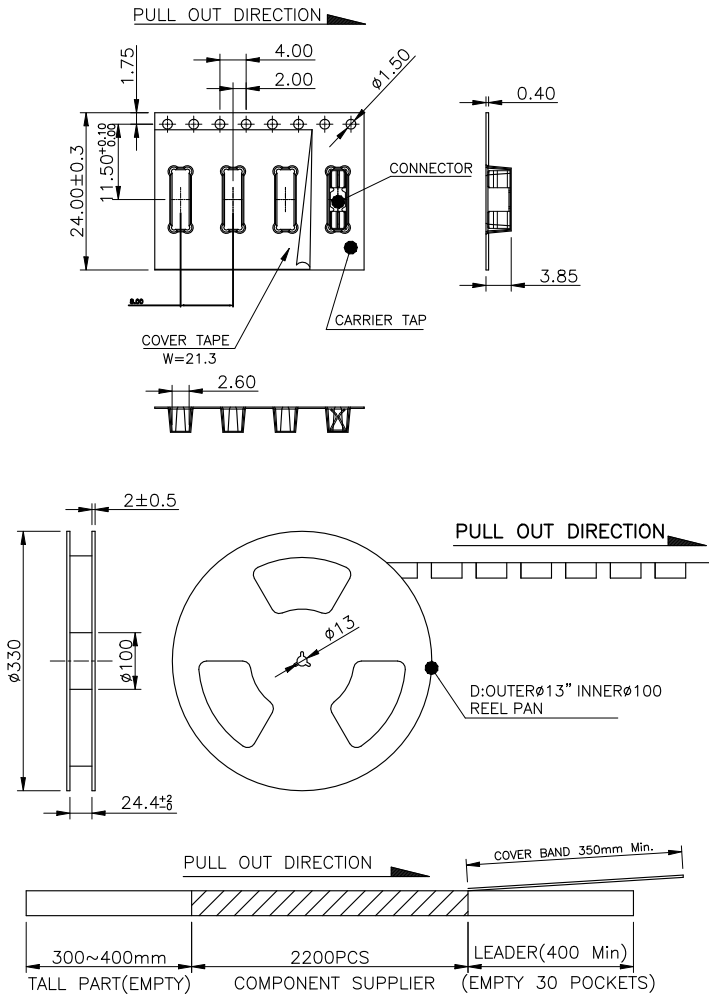

NOTES:

1. MATERIAL:
 - 1.1 CARRY TAPE:PS,T=0.4mm,COLOR:TRANSPARENT.
 - 1.2 REEL:HIPS,BLUE.
 - 1.3 SHIM:PE,CLEAR.
2. PRIMARY PACKING:2200PCS/REEL.
3. SECONDARY PACKING:10REELS/CARTON(22000PCS/CARTON).
4. PEELING RESISTANCE: 0.1N~0.9N(10~90gf);
PEELING ANGLE: 165°~180°;
PEELING SPEED: 300mm/minutes.
5. NET WEIGHT: 0.093g
6. CATON GROSS WEIGHT: 7.4Kg, NET WEIGHT: 2.05Kg

2

2. PACKING INTO CARTON:

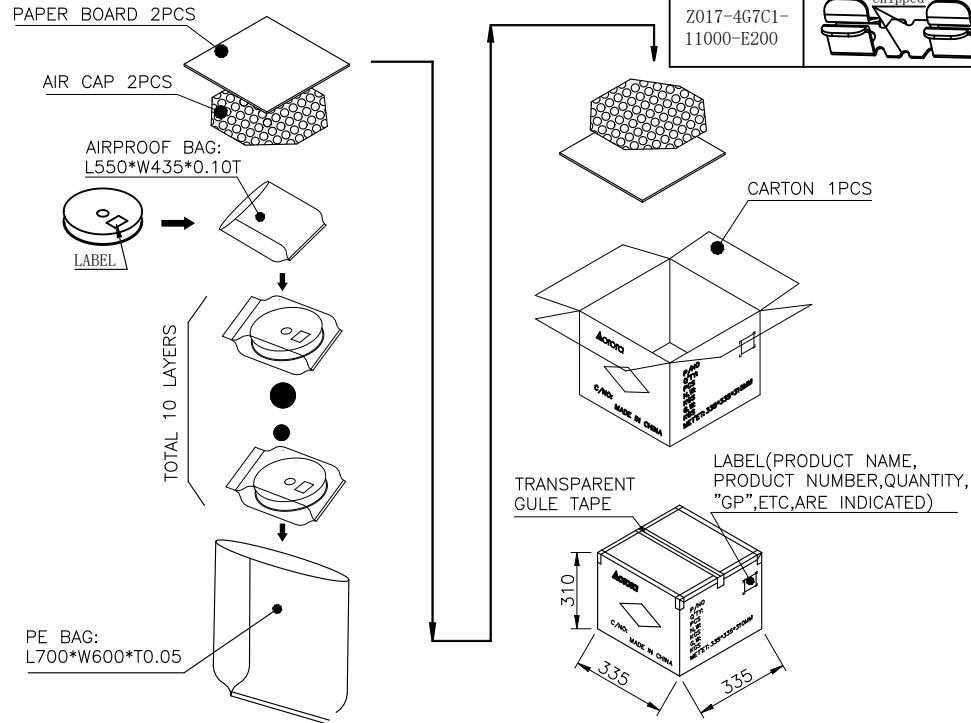

TABLE:

NO.	Sketch Map	Difference
Z002-4B7C1-11000		H3.4 Gap0.1mm
Z00U-4B7C1-11000		H3.4 Gap0.3mm
Z017-4G7C1-11000-E200		H3.4 Gap0.3mm Chipped

REV.	ECR/ECN No.	DESCRIPTION	DRAWN/DATE	CHECKED/DATE	APPROVED/DATE
C		New specifications	Staven 2019-03-04	Peng Li 2019-03-04	Judy 2019-03-04
D		UPDATE FRAME	Abner 2022-05-24	Staven 2022-05-24	Sam 2022-05-24

UNLESS OTHERWISE SPECIFIED TOLERANCES				ANGLE OF PROJECTION		Amphenol AORORA	
X.	±0.30	X. °	± 5'			Amphenol Aorora Technology (Huizhou) Co.,Ltd	
X.X	±0.25	X.X °	± 4'				
X.XX	±0.20	X.XX °	± 3'	DOC Typ Assembly Drw		TITLE: H3.4 CLIP	
X.XXX	±0.15	X.XXX °	± 2'	DRAWN	Abner	DATE	2022-05-24
LINEAR DIMS		ANGLES DIMS		DESIGN	Abner	DATE	2022-05-24
DWG NO.: A-H0167		MATERIAL		CHECKED	Staven	DATE	2022-05-24
FINISHED		SEE NOTES		APPROVED	Sam	DATE	2022-05-24
SIZE	PART NUMBER:		REV.	D			
A4	SEE TABLE		SCALE 1:1 UNIT: mm SHEET 1 OF 1				

1

2

3

4