

Features

- Fully integrated, PLL-stabilized VCO
- Frequency range from 310 MHz to 440 MHz
- FSK through crystal pulling allows modulation from DC to 40 kbit/s
- High FSK deviation possible for wideband data transmission
- ASK achieved by on/off keying of internal power amplifier
- FM possible with external varactor
- Wide power supply range from 2.2 V to 5.5 V
- High over-all frequency accuracy
- Very low standby current
- Adjustable equivalent radiated power (ERP) range from -25 dBm to -10 dBm
- Adjustable current consumption from 4.8 mA to 11.5 mA
- FSK deviation and center frequency independently adjustable
- Differential output well-suited for loop antenna
- External clock available for μ C drive, down to 1.9 V supply
- "Clock only" mode
- Conforms to EN 300 220 and similar standards

Ordering Information

Part No.

EVB7107-433-FSK
EVB7107-433-ASK

EVB7107-315-FSK
EVB7107-315-ASK

Application Examples

- Keyless car and central locking
- Low-power telemetry
- Alarm and security systems
- General digital data transmission
- General analog audio signal transmission

General Description

The TH7107 antenna board is designed to optimally match the differential power amplifier output to a loop antenna. The TH7107 can be populated either for FSK, ASK or FM transmission. The default population is for FSK or ASK transmission. Adding a varactor diode can easily be done in order to modify the circuit for analog FM. The evaluation board contains a differential-drive loop antenna printed on the PCB (Printed Circuit Board). The size of the loop antenna is matched to the resonant frequency.

Evaluation Board Example

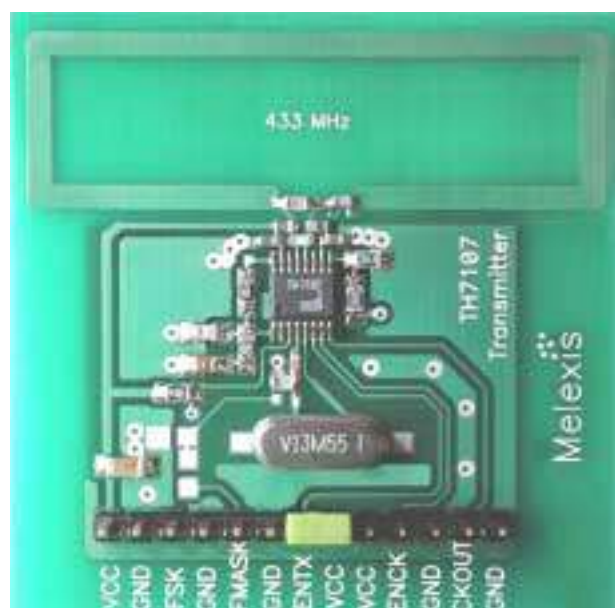

Document Content

1	Theory of Operation	3
1.1	General	3
1.2	Block Diagram	3
2	Functional Description	4
2.1	FSK Modulation	4
2.2	Frequency Modulation	4
2.3	ASK Modulation	4
2.4	Mode Control Logic	4
3	Circuit Diagram	5
3.1	PCB Top View	6
3.2	Board Connection	6
3.3	Board Component Values	7
4	Package Information	8
5	Disclaimer	10

1 Theory of Operation

1.1 General

As depicted in Fig.1, the TH71071 transmitter consists of a fully integrated voltage-controlled oscillator (VCO), a divide-by-32 divider (div32), a phase-frequency detector (PFD) and a charge pump. An external loop filter at pin LF determines the dynamic behaviour of the PLL and suppresses reference spurious signals. The VCO's output signal feeds the power amplifier (PA). RF signal power P_o can be adjusted in six steps from $P_o = -12$ dBm to +2 dBm either by changing the value of resistor R1 or by varying the voltage V_{PS} at pin PS/DATA. The open-collector differential output (OUT1, OUT2) can be used to either directly drive a loop antenna or to be converted to a single-ended impedance by means of a balanced-to-unbalanced (balun) transformer. For maximum available output power, the differential output should be matched to a load of about 1 k Ω .

Bandgap biasing ensures stable operation of the IC at a power supply range of 2.2 V to 5.5 V.

1.2 Block Diagram

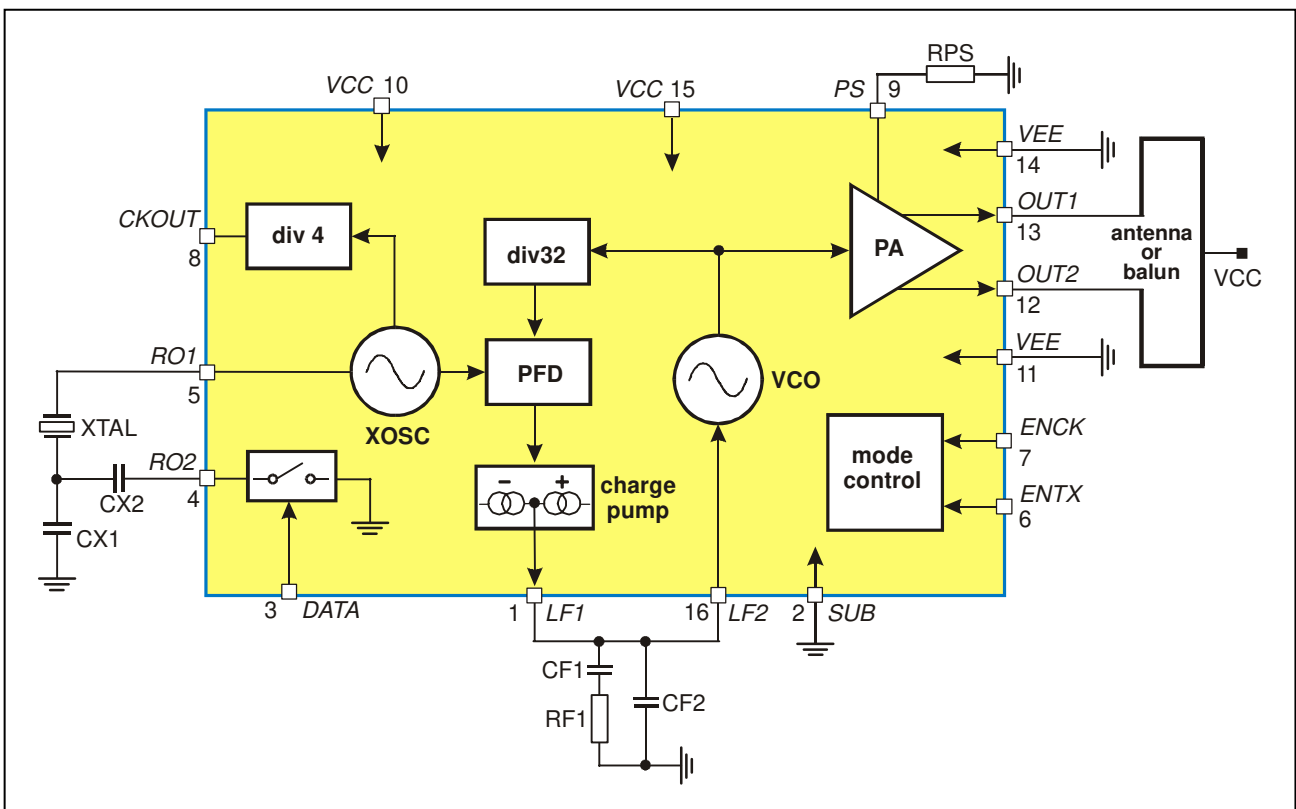

Fig. 1: Block diagram with external components

2 Functional Description

2.1 FSK Modulation

A Colpitts crystal oscillator (XOSC) is used as the reference oscillator of a phase-locked loop (PLL) synthesizer. FSK modulation is achieved by pulling the crystal (XTAL) through the data. So a CMOS-compatible data stream applied at input DATA digitally modulates the XOSC. Two external pulling capacitors CX1 and CX2 allow the FSK deviation and center frequency to be adjusted independently. At DATA = LOW CX2 is connected in parallel to CX1 leading to the low-frequency component of the FSK spectrum (f_{min}); while at DATA = HIGH CX2 is deactivated and the XOSC is set to its high frequency, leading to f_{max} .

An external reference signal can be directly AC-coupled to pin RO1. Then the TH7107 is used without an XTAL. The reference signal has to contain the FSK (or FM) and sets the carrier frequency.

2.2 Frequency Modulation

For FM operation an external varactor is required. It simply acts as a pulling capacitor connected in series to the crystal. Then the analog modulation signal, applied through a series resistor, directly modulates the XOSC.

2.3 ASK Modulation

The TH7107 can be ASK-modulated by applying data directly at pin PS. This turns the PA on and off and therefore leads to an ASK signal at the output.

2.4 Mode Control Logic

The mode control logic allows four different modes of operation as listed in the following table. The mode control pins ENCK and ENTX are pulled-down internally. This guarantees that the whole circuit is shut down if these pins are left floating.

The clock output CKOUT can be used to drive a μ C. This output can be activated by the ENCK pin as required for any specific application. Clock frequency is 1/4 of the reference crystal frequency.

ENCK	ENTX	Mode	Description
0	0	all OFF	whole circuit in standby
0	1	TX only	TX active, no clock available
1	0	clock only	TX standby and clock available
1	1	all ON	TX active and clock available

For more detailed information, please refer to the latest TH7107 data sheet revision.

3 Circuit Diagram

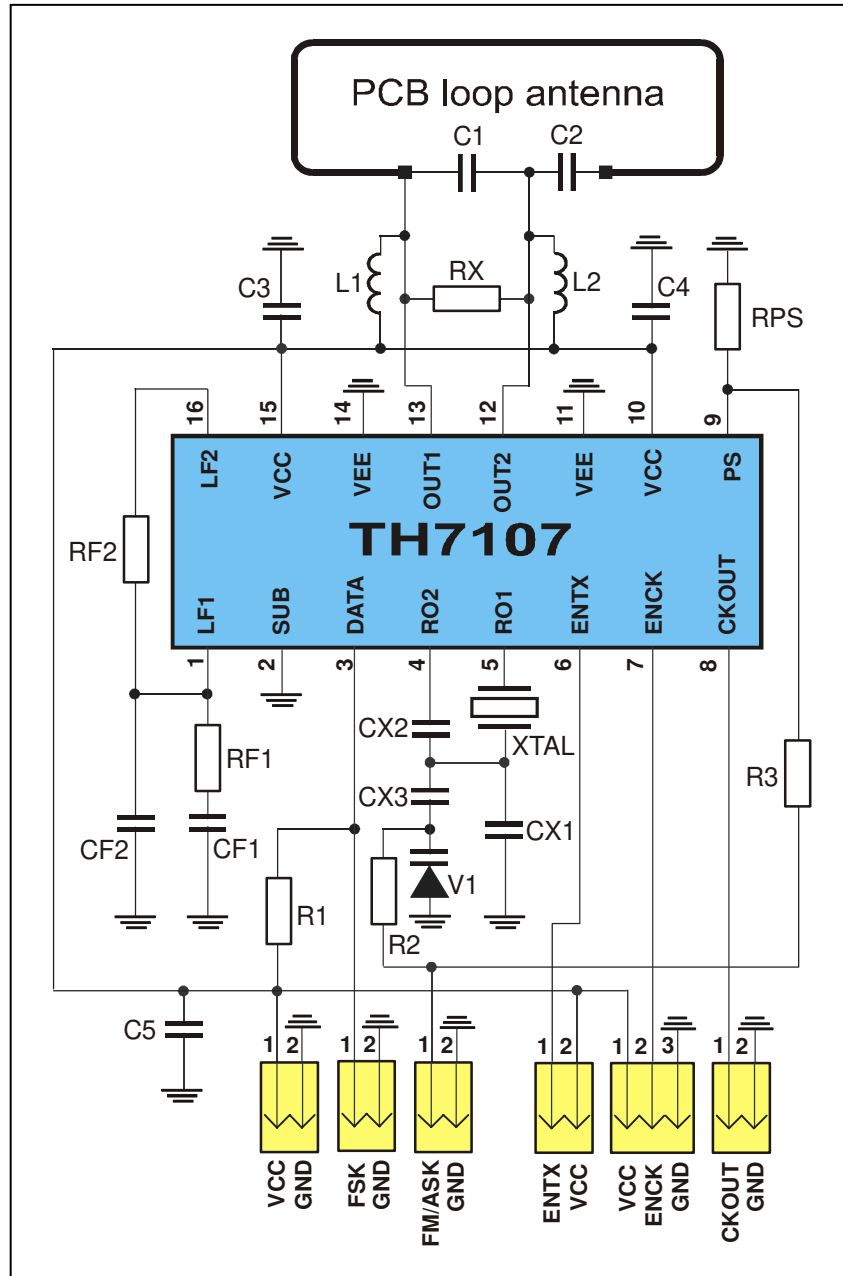

3.1 PCB Top View

Board layout data in Gerber format is available

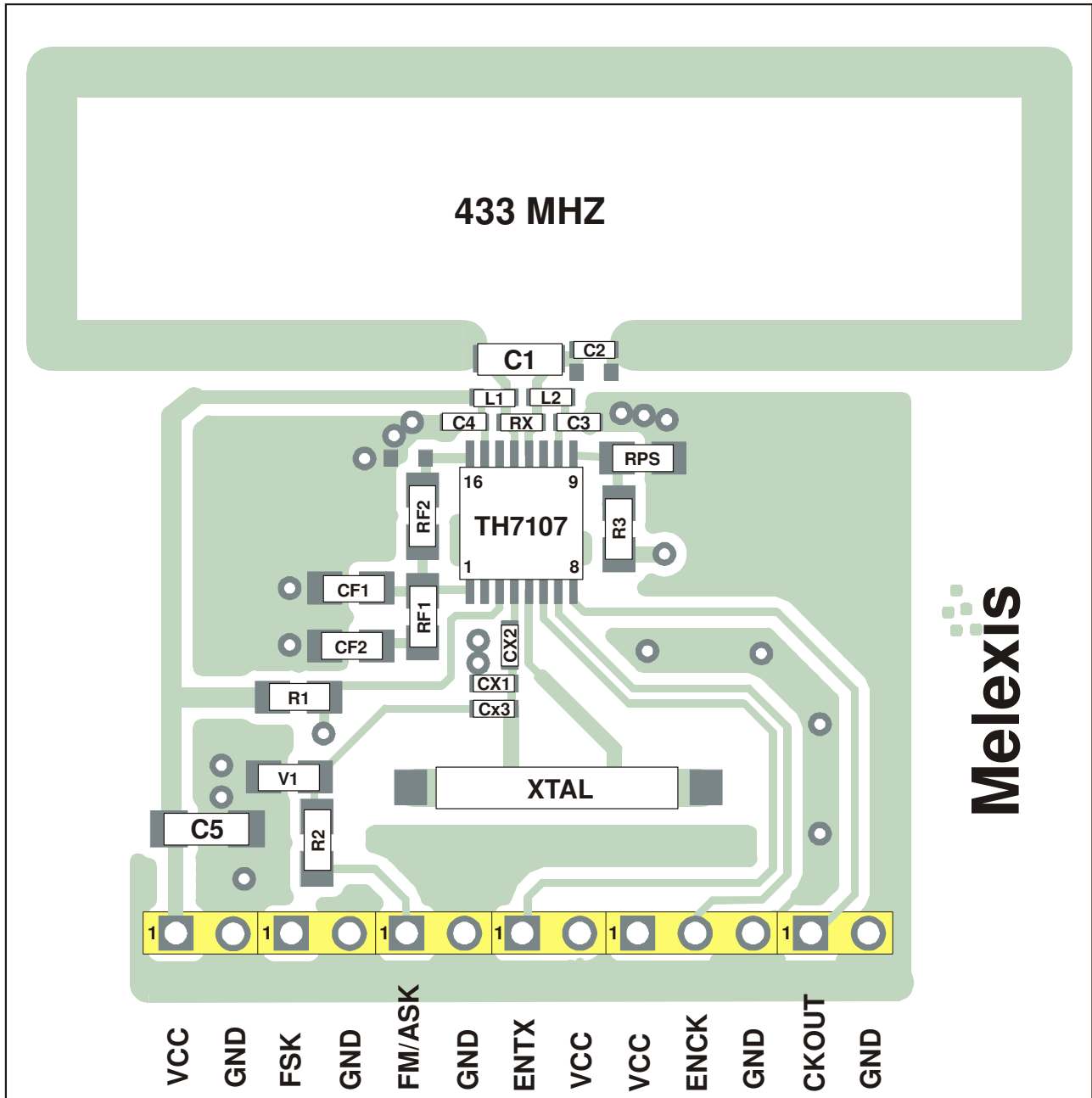

Board size is 48mm x 48mm

3.2 Board Connection

VCC	Power supply (2.2 V to 5.5 V)	ENCK	Mode control pin (see para. 2.4))
FSK	Input for FSK data (CMOS)	ENTX	Mode control pin (see para. 2.4))
FM/ASK	Input for FM signal (analog) or ASK data (CMOS)	GND	Several ground pins
CKOUT	Clock output (3.4 MHz)		

3.3 Board Component Values

Part	Size	Value 315 MHz	Value 433.6 MHz	Tolerance	Description
CF1	0805	12 nF	10 nF	±10%	loop filter capacitor
CF2	0805	15 pF	12 pF	±10%	loop filter capacitor
CX1_FSK	0603	39 pF	39 pF	±5%	XOSC capacitor for FSK ($\Delta f = \pm 20$ kHz)
CX1_ASK	0603	68 pF	68 pF	±5%	XOSC capacitor for ASK, trimmed to f_c
CX2	0603	1 nF	1 nF	±5%	XOSC capacitor, only needed for FSK
CX3	0603	1 nF	1 nF	±10%	XOSC capacitor, only needed for FM
C1	1206	3.9 pF	3.9 pF	±2%	antenna resonance capacitor
C2	0805	3.9 pF	2.2 pF	±2%	antenna resonance capacitor
C3	0603	330 pF	330 pF	±10%	blocking capacitor
C4	0603	330 pF	330 pF	±10%	blocking capacitor
C5	1206	220 nF	220 nF	±20%	blocking capacitor
L1	0603	220 nH	220 nH	±10%	biasing inductor
L2	0603	220 nH	220 nH	±10%	biasing inductor
RF1	0805	2.0 k Ω	2.0 k Ω	±10%	loop filter resistor
RF2	0805	4.3 k Ω	4.3 k Ω	±10%	loop filter resistor
RPS	0805	56 k Ω	56 k Ω	±10%	power-select resistor, see data sheet para. 4.6
R1	0805	470 k Ω	470 k Ω	±10%	optional pull-up resistor, typically not needed
R2	0805	30 k Ω	30 k Ω	±10%	varactor bias resistor, only needed for FM
R3	0805	0 Ω	0 Ω	±10%	ASK jumper, only needed for ASK
RX	0603	4.7 k Ω	4.7 k Ω	±10%	damping resistor
V1	SOD323	BB535			varactor diode, only needed for FM
XTAL	HC49/S	9.8438 MHz fundamental wave	13.5500 MHz fundamental wave	±30ppm calibration ±30ppm temp.	crystal, $C_{load} = 12$ pF to 15 pF, $C_0, max = 7$ pF $R_{m, max} = 40$ Ω
PCB loop antenna	long side length	44 mm	44 mm		on FR4 PCB material side length including length of C1 and C2
PCB loop antenna	small side length	20 mm	12 mm		on FR4 PCB material
PCB loop antenna	Line width	2 mm	2 mm		on FR4 PCB material

The listed component values are default values. All values might be changed to fit to any specific application. As for example FSK deviation can be set by varying CX1 and CX2, output power at FSK/FM transmission can be changed through RPS or through RPS and R3 at ASK transmission, respectively.

Pads for C1 are for population of a fixed-value capacitor with size 1206 or a to use trimming capacitor either.

4 Package Information

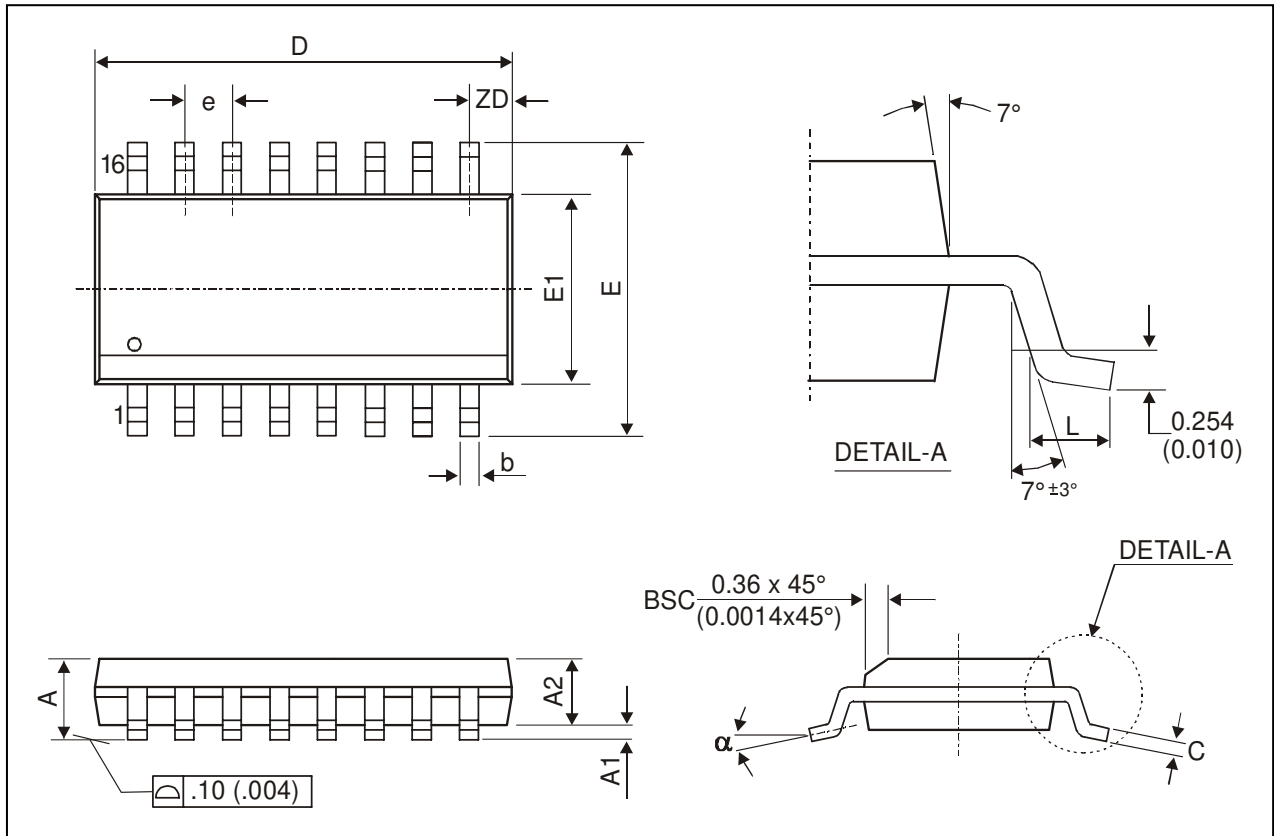

Fig. 2: QSOP16 (Quarter size Small Outline Package)

all Dimension in mm, coplanarity < 0.1mm												
	D	E1	E	A	A1	A2	e	b	ZD	C	L	α
min	4.80	3.81	5.79	1.35	0.10	1.37	0.635	0.20	0.230	0.19	0.40	0°
max	4.98	3.99	6.20	1.75	0.25	1.50	0.635	0.30	0.230	0.25	1.27	8°
all Dimension in inch, coplanarity < 0.004"												
min	0.189	0.150	0.228	0.0532	0.0040	0.054	0.025	0.008	0.009	0.075	0.016	0°
max	0.196	0.157	0.244	0.0688	0.0098	0.059	0.025	0.012	0.009	0.098	0.050	8°

Your Notes

5 Disclaimer

Devices sold by Melexis are covered by the warranty and patent indemnification provisions appearing in its Term of Sale. Melexis makes no warranty, express, statutory, implied, or by description regarding the information set forth herein or regarding the freedom of the described devices from patent infringement. Melexis reserves the right to change specifications and prices at any time and without notice. Therefore, prior to designing this product into a system, it is necessary to check with Melexis for current information. This product is intended for use in normal commercial applications. Applications requiring extended temperature range, unusual environmental requirements, or high reliability applications, such as military, medical life-support or life-sustaining equipment are specifically not recommended without additional processing by Melexis for each application.

The information furnished by Melexis is believed to be correct and accurate. However, Melexis shall not be liable to recipient or any third party for any damages, including but not limited to personal injury, property damage, loss of profits, loss of use, interrupt of business or indirect, special incidental or consequential damages, of any kind, in connection with or arising out of the furnishing, performance or use of the technical data herein. No obligation or liability to recipient or any third party shall arise or flow out of Melexis' rendering of technical or other services.

© 2002 Melexis NV. All rights reserved.

For the latest version of this document. Go to our website at
www.melexis.com

Or for additional information contact Melexis Direct:

Europe and Japan:
Phone: +32 1367 0495
E-mail: sales_europe@melexis.com

All other locations:
Phone: +1 603 223 2362
E-mail: sales_usa@melexis.com

QS9000, VDA6.1 and ISO14001 Certified