

74FCT534 Octal D Flip-Flop with TRI-STATE® Outputs

General Description

The 'FCT534 is a high-speed, low-power octal D-type flip-flop featuring separate D-type inputs for each flip-flop and TRI-STATE outputs for bus-oriented applications. A buffered Clock (CP) and Output Enable (\overline{OE}) are common to all flip-flops. FACT™ FCT utilizes NSC quiet series technology to provide improved quiet output switching and dynamic threshold performance.

FACT FCT features GTO™ output control and undershoot corrector in addition to a split ground bus for superior performance. The 'FCT534 is the same as the 'FCT374 except that the outputs are inverted.

Features

- I_{CC} and I_{OZ} reduced to 40.0 μA and $\pm 2.5 \mu A$ respectively
- NSC 54/74FCT534 is pin and functionally equivalent to IDT 54/74FCT534
- Edge-triggered D-type inputs
- Buffered positive edge-triggered clock
- Input clamp diodes to limit bus reflections
- TTL/CMOS input and output level compatible
- $I_{OL} = 48 \text{ mA}$
- CMOS power levels
- ESD immunity $\geq 4 \text{ kV typ}$

Logic Symbols

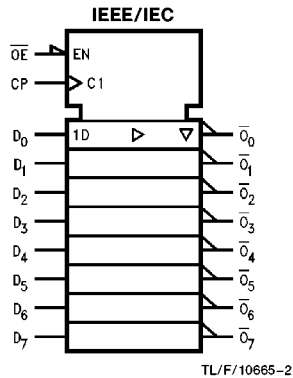
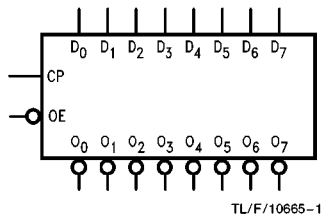

Connection Diagram

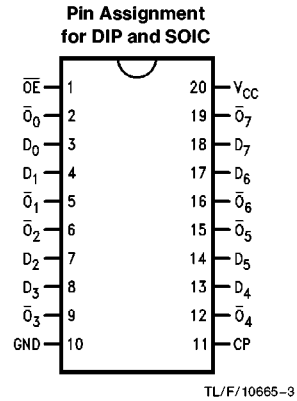

Pin Names	Description
D_0 - D_7	Data Inputs
CP	Clock Pulse Input
\overline{OE}	TRI-STATE Output Enable Input
\overline{O}_0 - \overline{O}_7	Complementary TRI-STATE Outputs

TRI-STATE® is a registered trademark of National Semiconductor Corporation.
FACT™ and GTO™ are trademarks of National Semiconductor Corporation.

Functional Description

The 'FCT534 consists of eight edge-triggered flip-flops with individual D-type inputs and TRI-STATE complementary outputs. The buffered clock and buffered Output Enable are common to all flip-flops. The eight flip-flops will store the state of their individual D inputs that meet the setup and hold times requirements on the LOW-to-HIGH Clock (CP)

transition. With the Output Enable (\overline{OE}) LOW, the contents of the eight flip-flops are available at the outputs. When the \overline{OE} is HIGH, the outputs go to the high impedance state. Operation of the \overline{OE} input does not affect the state of the flip-flops.

Logic Diagram

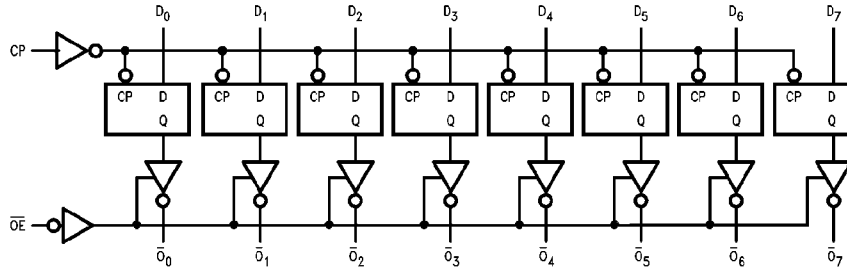

TL/F/10665-5

Please note that this diagram is provided only for the understanding of logic operations and should not be used to estimate propagation delays.

Function Table

Inputs			Output
CP	OE	D	\overline{O}
⤴	L	H	L
⤴	L	L	H
L	L	X	\overline{O}_0
X	H	X	Z

H = HIGH Voltage Level

L = LOW Voltage Level

X = Immaterial

⤴ = LOW-to-HIGH Clock Transition

Z = High Impedance

\overline{O}_0 = Value stored from previous clock cycle

Absolute Maximum Ratings (Note 1)

If Military/Aerospace specified devices are required, please contact the National Semiconductor Sales Office/Distributors for availability and specifications.

Terminal Voltage with Respect to GND (V _{TERM}) 74FCT	-0.5V to +7.0V
Temperature Under Bias (T _{BIAS}) 74FCT	-55°C to +125°C
Storage Temperature (T _{STG}) 74FCT	-55°C to +125°C
DC Output Current (I _{OUT})	120 mA

Note 1: Absolute maximum ratings are those values beyond which damage to the device may occur. Exposure to absolute maximum rating conditions for extended periods may affect reliability. The databook specifications should be met, without exception, to ensure that the system design is reliable over its power supply, temperature, and output/input loading variables.

Recommended Operating Conditions

Supply Voltage (V _{CC}) 74FCT	4.75V to 5.25V
Input Voltage	0V to V _{CC}
Output Voltage	0V to V _{CC}
Operating Temperature (T _A) 74FCT	-0°C to +70°C
Junction Temperature (T _J) PDIP	140°C

Note: All commercial packaging is not recommended for applications requiring greater than 2000 temperature cycles from -40°C to +125°C.

DC Characteristics for 'FCTA Family Devices

Typical values are at V_{CC} = 5.0V, 25°C ambient and maximum loading. For test conditions shown as Max, use the value specified for the appropriate device type: Com: V_{CC} = 5.0V ± 5%, T_A = 0°C to +70°C; V_{HC} = V_{CC} - 0.2V.

Symbol	Parameter	74FCTA			Units	Conditions
		Min	Typ	Max		
V _{IH}	Minimum High Level Input Voltage	2.0			V	
V _{IL}	Maximum Low Level Input Voltage			0.8	V	
I _{IH}	Input High Current		5.0	5.0	μA	V _{CC} = Max V _I = V _{CC} V _I = 2.7V (Note 2)
I _{IL}	Input Low Current		-5.0	-5.0	μA	V _{CC} = Max V _I = 0.5V (Note 2) V _I = GND
I _{OZ}	Maximum TRI-STATE Current		2.5	2.5	μA	V _{CC} = Max V _O = V _{CC} V _O = 2.7V (Note 2) V _O = 0.5V (Note 2) V _O = GND
V _{IK}	Clamp Diode Voltage	-0.7	-1.2		V	V _{CC} = Min; I _N = -18 mA
I _{OS}	Short Circuit Current	-60	-120		mA	V _{CC} = Max (Note 1); V _O = GND
V _{OH}	Minimum High Level Output Voltage	2.8	3.0		V	V _{CC} = 3V; V _{IN} = 0.2V or V _{HC} ; I _{OH} = -32 μA V _{CC} = Min V _{IN} = V _{IH} or V _{IL} ; I _{OH} = -15 mA
V _{OL}	Maximum Low Level Output Voltage		GND	0.2	V	V _{CC} = 3V; V _{IN} = 0.2V or V _{HC} ; I _{OL} = 300 μA V _{CC} = Min V _{IN} = V _{IH} or V _{IL} ; I _{OL} = 48 mA

DC Characteristics for 'FCT Family Devices (Continued)

Typical values are at $V_{CC} = 5.0V$, $25^{\circ}C$ ambient and maximum loading. For test conditions shown as Max, use the value specified for the appropriate device type: Com: $V_{CC} = 5.0V \pm 5\%$, $T_A = 0^{\circ}C$ to $+70^{\circ}C$; $V_{HC} = V_{CC} - 0.2V$.

Symbol	Parameter	74FCT			Units	Conditions
		Min	Typ	Max		
I_{CC}	Maximum Quiescent Supply Current	1.0	40.0		μA	$V_{CC} = \text{Max}$ $V_{IN} \geq V_{HC}$, $V_{IN} \leq 0.2V$ $f_I = 0$
ΔI_{CC}	Quiescent Supply Current; TTL Inputs HIGH	0.5	2.0		mA	$V_{CC} = \text{Max}$ $V_{IN} = 3.4V$ (Note 3)
I_{CCD}	Dynamic Power Supply Current (Note 4)	0.15	0.25		mA/MHz	$V_{CC} = \text{Max}$ Outputs Open $\overline{OE} = \text{GND}$ One Input Toggling 50% Duty Cycle $V_{IN} \geq V_{HC}$ $V_{IN} \leq 0.2V$
I_C	Total Power Supply Current (Note 6)	1.5	4.0		mA	$V_{CC} = \text{Max}$ Outputs Open $f_{CP} = 10 \text{ MHz}$ $\overline{OE} = \text{GND}$ $f_I = 5 \text{ MHz}$ One Bit Toggling 50% Duty Cycle $V_{IN} \geq V_{HC}$ $V_{IN} \leq 0.2V$
		1.8	6.0			$V_{IN} = 3.4V$ $V_{IN} = \text{GND}$
		3.0	7.8			(Note 5) $V_{CC} = \text{Max}$ Outputs Open $\overline{OE} = \text{GND}$ $f_{CP} = 10 \text{ MHz}$ $f_I = 2.5 \text{ MHz}$ Eight Bits Toggling 50% Duty Cycle $V_{IN} \geq V_{HC}$ $V_{IN} \leq 0.2V$
		5.0	16.8			$V_{IN} = 3.4V$ $V_{IN} = \text{GND}$
V_H	Input Hysteresis on Clock Only	200			mV	

Note 1: Maximum test duration not to exceed one second, not more than one output shorted at one time.

Note 2: This parameter guaranteed but not tested.

Note 3: Per TTL driven input ($V_{IN} = 3.4V$); all other inputs at V_{CC} or GND.

Note 4: This parameter is not directly testable, but is derived for use in Total Power Supply calculations.

Note 5: Values for these conditions are examples of the I_{CC} formula. These limits are guaranteed but not tested.

Note 6: $I_C = I_{\text{QUIESCENT}} + I_{\text{INPUTS}} + I_{\text{DYNAMIC}}$

$$I_C = I_{CC} + \Delta I_{CC} D_H N_T + I_{CCD} (f_{CP}/2 + f_I N_I)$$

I_{CC} = Quiescent Current

ΔI_{CC} = Power Supply Current for a TTL High Input ($V_{IN} = 3.4V$)

D_H = Duty Cycle for TTL inputs High

N_T = Number of Inputs at D_H

I_{CCD} = Dynamic Current Caused by an Input Transition Pair (HLH or LHL)

f_{CP} = Clock Frequency for Register Devices (Zero for Non-Register Devices)

f_I = Input Frequency

N_I = Numbers of Inputs at f_I

All currents are in milliamps and all frequencies are in megahertz.

AC Electrical Characteristics

Symbol	Parameter	74FCT	74FCT		Units
		$T_A = +25^\circ\text{C}$ $V_{CC} = 5.0\text{V}$	$T_A, V_{CC} = \text{Com}$ $C_L = 50\text{ pF}$		
		Typ	Min (Note 1)	Max	
t_{PLH} t_{PHL}	Propagation Delay C _P to \bar{O}_n	6.5	1.5	10.0	ns
t_{PZH} t_{PZL}	Output Enable Time	9.0	1.5	12.5	ns
t_{PHZ} t_{PLZ}	Output Disable Time	6.0	1.5	8.0	ns
t_s	Set Up Time High or Low D _n to C _P	1.0	2.0		ns
t_h	Hold Time High or Low D _n to C _P	0.5	1.5		ns
t_w	CP Pulse Width High or Low	4.0	7.0		ns

Note 1: Minimum limits guaranteed but not tested on propagation delays.

Capacitance $T_A = +25^\circ\text{C}, f_I = 1.0\text{ MHz}$

Symbol	Parameter	Typ	Max	Units	Conditions
C_{IN}	Input Capacitance	6	10	pF	$V_{IN} = 0\text{V}$
C_{OUT}	Output Capacitance	8	12	pF	$V_{OUT} = 0\text{V}$

Note: This parameter is measured at characterization but not tested.
 C_{OUT} for 74FCT only.

Ordering Information

The device number is used to form part of a simplified purchasing code where a package type and temperature range are defined as follows:

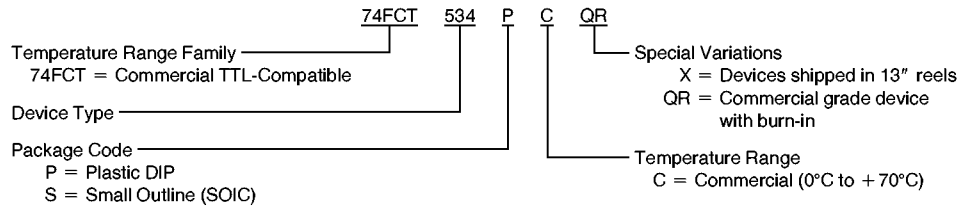

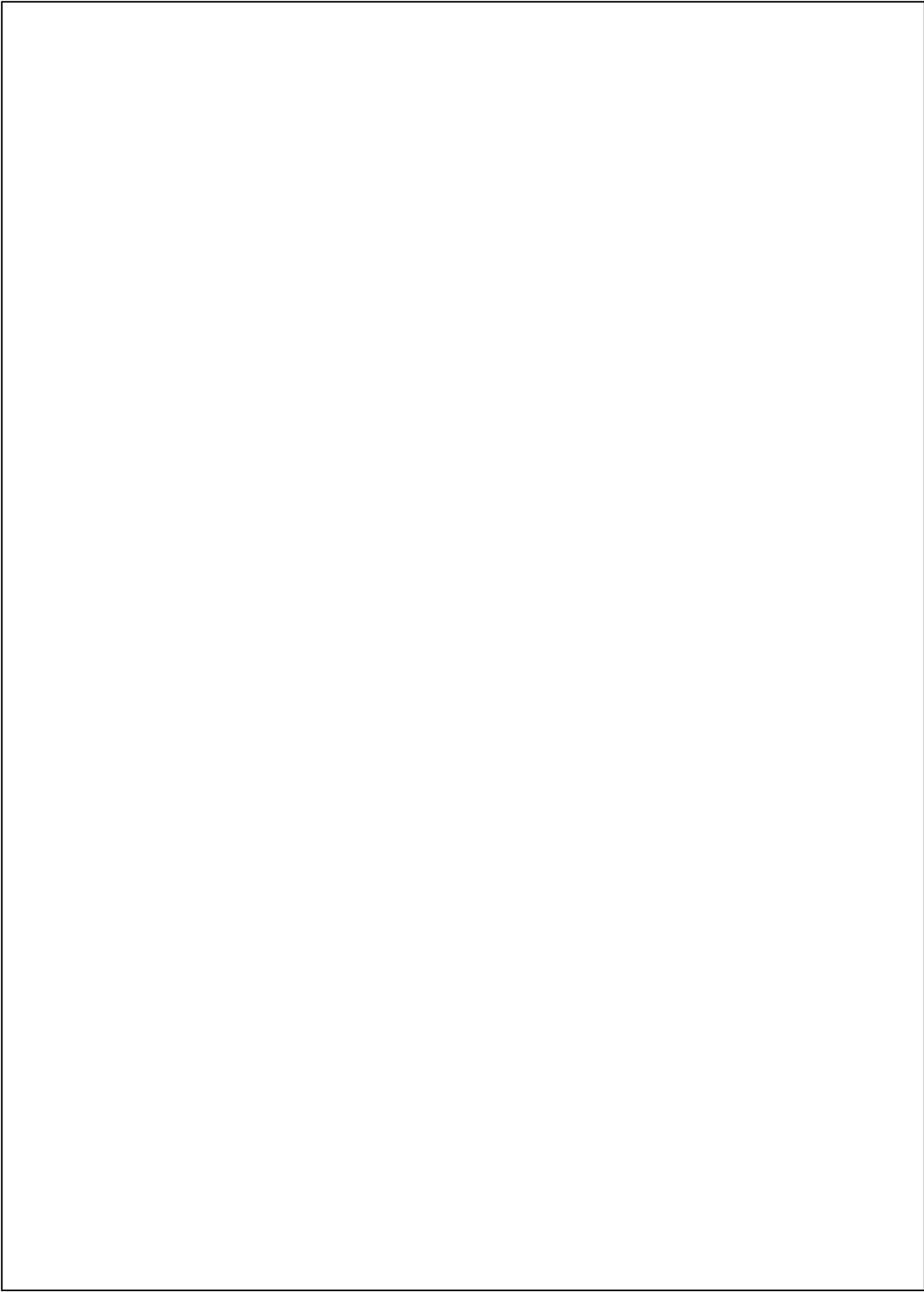

Physical Dimensions inches (millimeters)

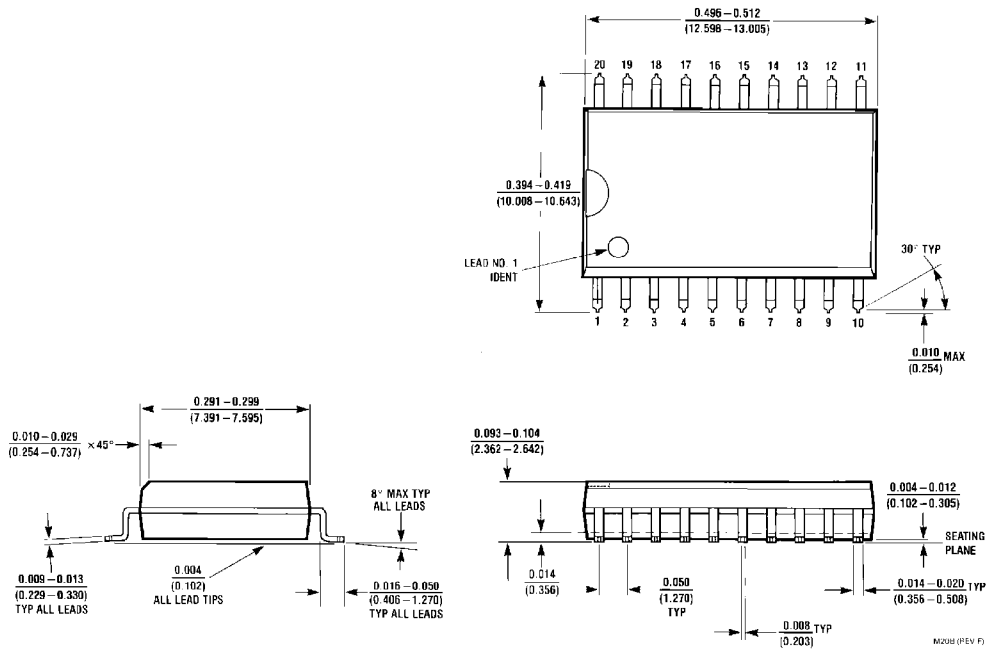

**20-Lead Small Outline Integrated Circuit (S)
NS Package Number M20B**

M20B (REV. F)

Physical Dimensions inches (millimeters) (Continued)

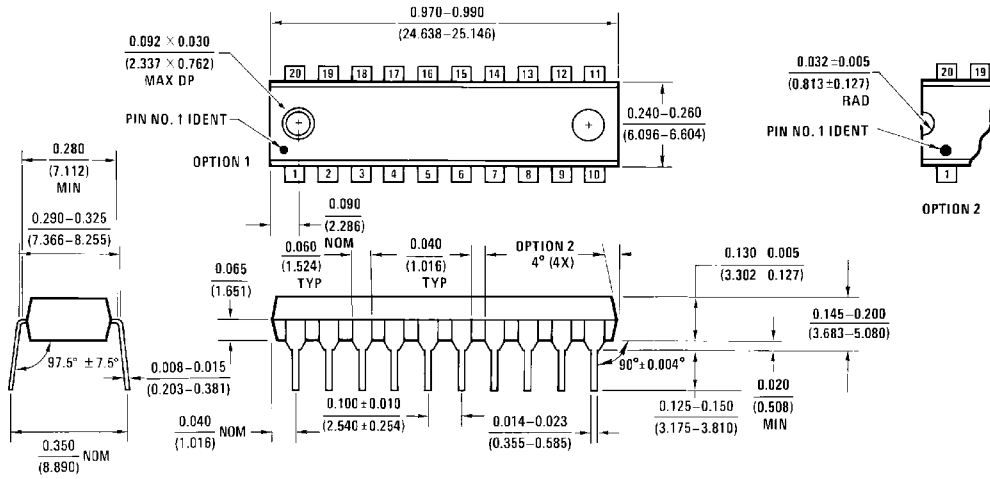

**20-Lead Plastic Dual-In-Line Package (P)
NS Package Number N20B**

N20B (REV A)

LIFE SUPPORT POLICY

NATIONAL'S PRODUCTS ARE NOT AUTHORIZED FOR USE AS CRITICAL COMPONENTS IN LIFE SUPPORT DEVICES OR SYSTEMS WITHOUT THE EXPRESS WRITTEN APPROVAL OF THE PRESIDENT OF NATIONAL SEMICONDUCTOR CORPORATION. As used herein:

1. Life support devices or systems are devices or systems which, (a) are intended for surgical implant into the body, or (b) support or sustain life, and whose failure to perform, when properly used in accordance with instructions for use provided in the labeling, can be reasonably expected to result in a significant injury to the user.
2. A critical component is any component of a life support device or system whose failure to perform can be reasonably expected to cause the failure of the life support device or system, or to affect its safety or effectiveness.



National Semiconductor Corporation
1111 West Bardin Road
Arlington, TX 76017
Tel: 1(800) 272-9959
Fax: 1(800) 737-7018

National Semiconductor Europe
Fax: (+49) 0-180-530 85 86
Email: onjwge@tevm2.nsc.com
Deutsch Tel: (+49) 0-180-530 85 85
English Tel: (+49) 0-180-532 78 32
Français Tel: (+49) 0-180-532 93 58
Italiano Tel: (+49) 0-180-534 16 80

National Semiconductor Hong Kong Ltd.
13th Floor, Straight Block,
Ocean Centre, 5 Canton Rd.
Tsimshatsui, Kowloon
Hong Kong
Tel: (852) 2737-1600
Fax: (852) 2736-9960

National Semiconductor Japan Ltd.
Tel: 81-043-299-2309
Fax: 81-043-299-2408

National does not assume any responsibility for use of any circuitry described, no circuit patent licenses are implied and National reserves the right at any time without notice to change said circuitry and specifications.