



ANATECH ELECTRONICS INC
RF & Microwave Filters & Products

30 MHz Bandpass Filter

Part Number: AE30B10527



Electrical Specifications

Center Frequency: 30 MHz
3 dB Bandwidth: 0.8 MHz
Insertion Loss: <4 dB
Impedance: 50 Ohms
Rejection Frequency on low side: 28 MHz
Rejection Frequency on High side: 33 MHz
Attenuation at lower side reject frequencies: 35
Attenuation at higher side reject frequencies : 40
VSWR: 1:5:1 max
Power: 1Watt Max.

Mechanical

Mounting Method: Threaded Mounting Holes
Connector type: SMA (Female)
Dimensions: 2.38" X 1.0" x 1.0" in.

Environmental

Operating Temperature: -25°C to +70°C
Storage Temperature: -40°C to +90°C
Shock: 10 G. 11ms
Vibration: 10 G. 5 to 200 Hz

Outline Drawing:

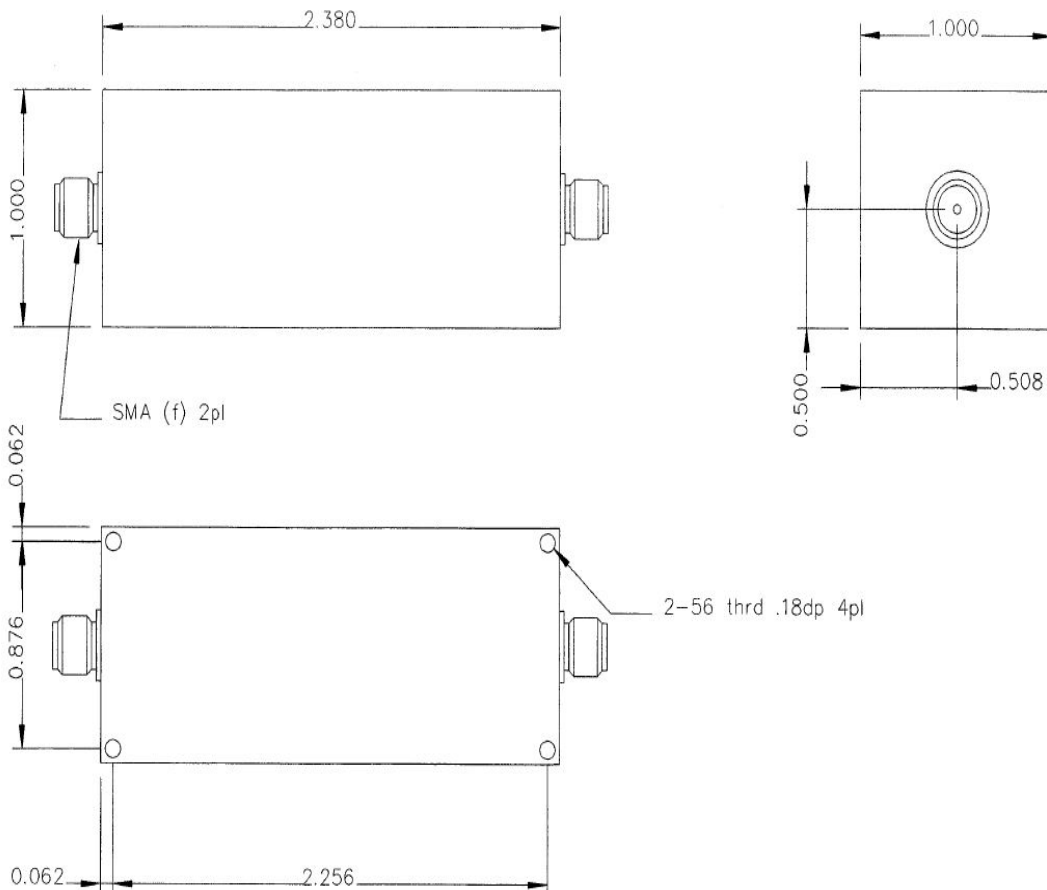



Simulation Response Plot:

