

PRODUCT NUMBER  
SEE TABLE

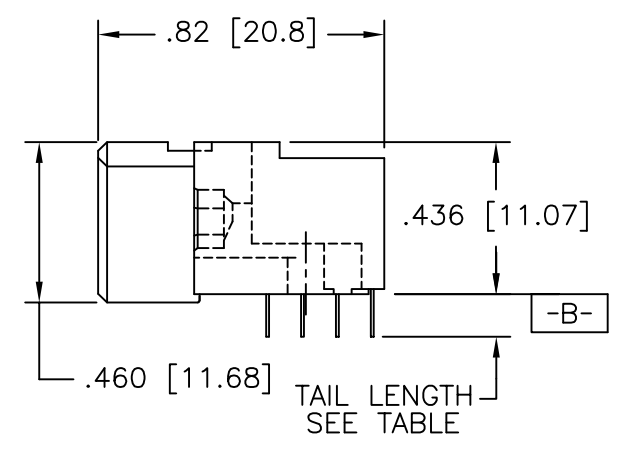
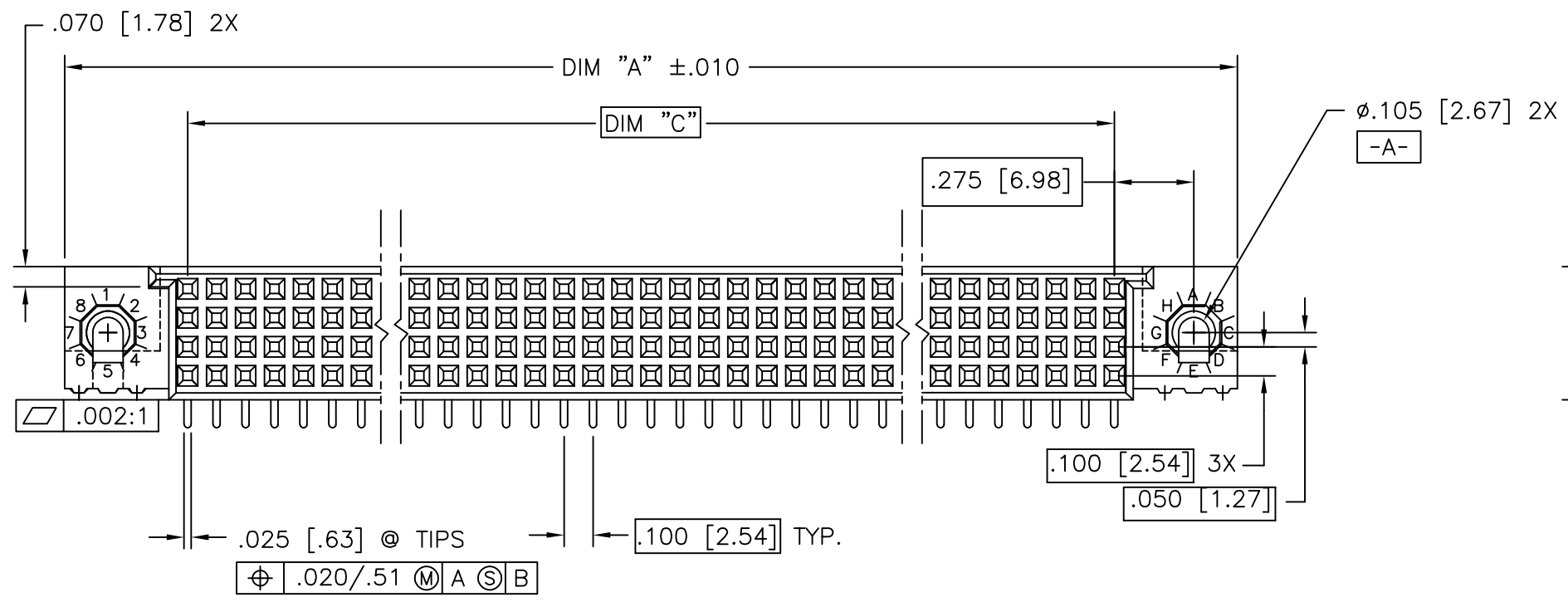
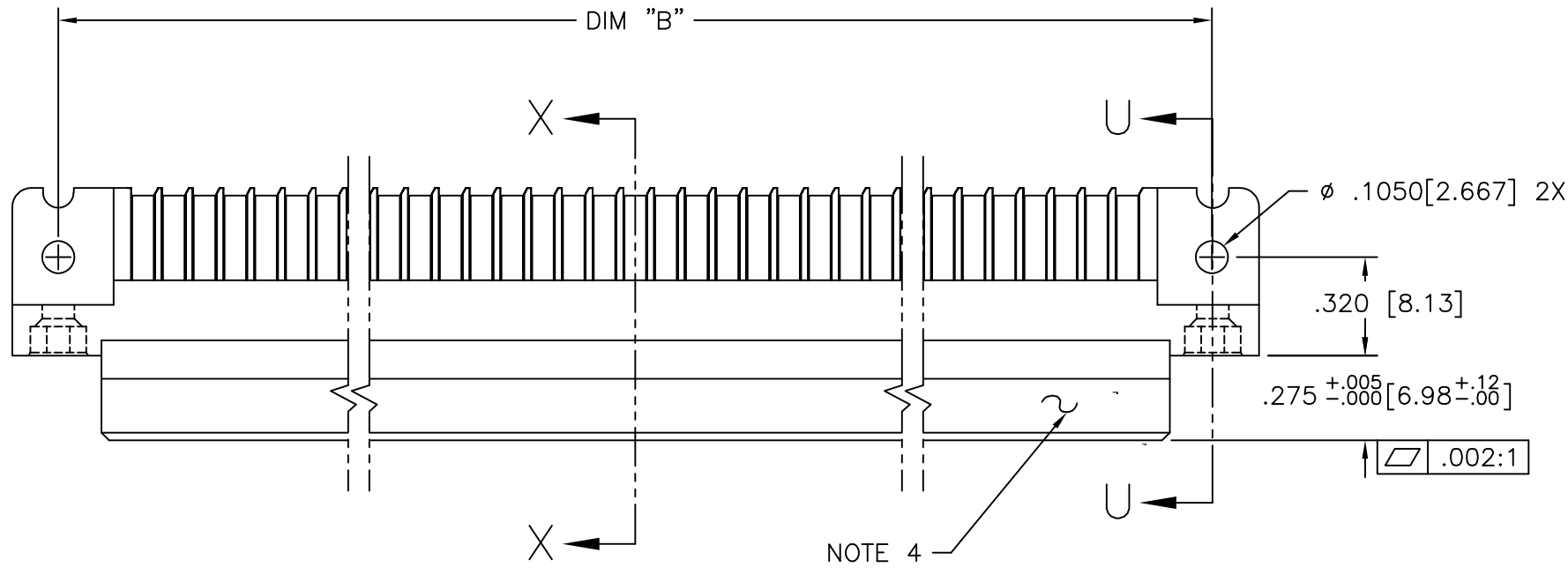

Φ .020/.51 (M) A (S) B

mat'l. code NOTE 3		surface ISO 1302 ✓		tolerance ISO 406 ISO 1101		projection INCH/MM		product family HPC	
ltr	ecn no	dr	date	tolerances unless otherwise specified		INCH/MM		title	
Y	I12-0005	SAL	2012-01-09	angles	linear	.XX±.01/.X±0.3		4 ROW R/A RECEPTACLE	
AA	ELX-I-31133	MJA	2018-09-01			.XXX±.005/.XX±0.13		GENERIC, MOUNT, S.T.B. 0 G.P.	
-	-	-	-			.XXX±.0020/.XXX±0.051		scale 1:1	
U	M06-0255	MHT	7/06/06	dr	D.SHEAFFER	1992-08-27		dwg no	
V	M06-0476	MHT	12/05/06	enr	S.CLARK	1992-09-30		sheet 1 of 5 size	
W	M07-0237	AGS	7/17/07	chr	M. JACOB	2018-09-01		50576 A3	
X	M08-0308	MHT	10/23/08	appd	BIJU K PAUL	2018-09-01		type Product Customer Drawing	
sheet	revision	AA	AA	Y	Y	A			
index	sheet	1	2	3	4	5			

PRODUCT NUMBER	NUMBER OF POSITIONS, NOTE 2	TAIL LENGTH	SOLDER TAIL PLATING	CONTACT AREA PLATING (NOTE 8)
50576-1YYYYE	YYY	.125±.010/3.18±.25	TIN-LEAD	30u"/.76u GOLD
50576-1YYYYELF	YYY	.125±.010/3.18±.25	TIN	30u"/.76u GXT
50576-1YYYYF	YYY	.145±.010/3.68±.25	TIN-LEAD	30u"/.76u GOLD
50576-1YYYYH	YYY	.180±.010/4.57±.25	TIN-LEAD	30u"/.76u GOLD
50576-3YYYYE	YYY	.125±.010/3.18±.25	TIN-LEAD	50u"/1.27u GOLD
50576-3YYYYF	YYY	.145±.010/3.68±.25	TIN-LEAD	50u"/1.27u GOLD
50576-3YYYYH	YYY	.180±.010/4.57±.25	TIN-LEAD	50u"/1.27u GOLD
50576-5YYYYE	YYY	.125±.010/3.18±.25	TIN-LEAD	30u"/.76u GXT
50576-5YYYYELF	YYY	.125±.010/3.18±.25	TIN	30u"/.76u GXT
50576-5YYYYF	YYY	.145±.010/3.68±.25	TIN-LEAD	30u"/.76u GXT
50576-5YYYYFLF	YYY	.145±.010/3.68±.25	TIN	30u"/.76u GXT
50576-5YYYYH	YYY	.180±.010/4.57±.25	TIN-LEAD	30u"/.76u GXT
50576-5YYYYHLF	YYY	.180±.010/4.57±.25	TIN	30u"/.76u GXT
50576-XX004	100	.125±.010/3.18±.25	TIN-LEAD	30u"/.76u GXT
50576-XX004LF	100	.125±.010/3.18±.25	TIN	30u"/.76u GXT
50576-XX008	80	.125±.010/3.18±.25	TIN-LEAD	30u"/.76u GOLD
50576-XX008LF	80	.125±.010/3.18±.25	TIN	30u"/.76u GXT
50576-XX009LF	80	.125±.010/3.18±.25	TIN	30u"/.76u GXT

NOTE 7 (CUSTOMER SPECIAL)

SEE SHEET 3

SEE SHEET 4

SEE SHEET 5

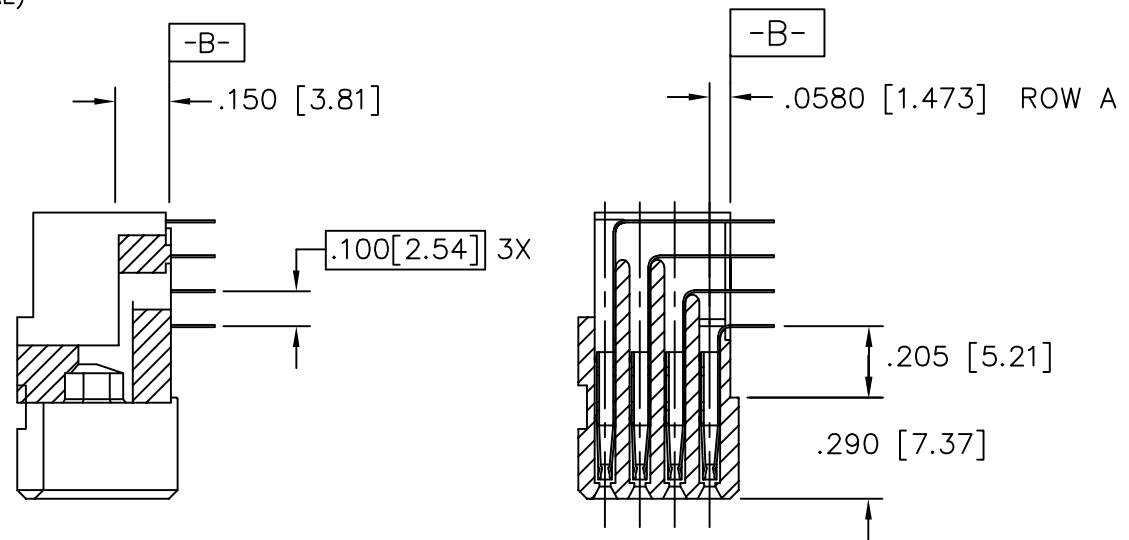

SECTION U-U SECTION X-X

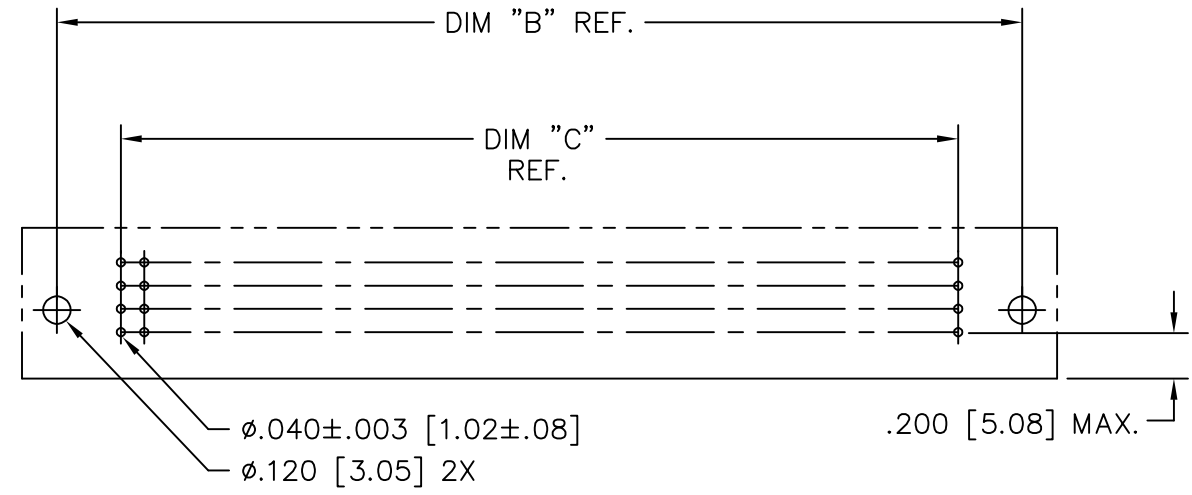

RECOMMENDED PCB LAYOUT  
(ALL HOLES LOCATED ON .100 [2.54] GRID UNLESS OTHERWISE SPECIFIED)

NOTES:

① PRODUCT NUMBERING CODE:  
50576 - X YYY Z LF  
LEAD FREE (OPTIONAL)  
TAIL LENGTH (NOTE 5)  
NO. OF POSITIONS (NOTE 2)  
PLATING (NOTE 4)  
BASE NUMBER

PRODUCT NUMBERING CODE FOR SELECT LOAD PART NUMBERS:  
50576 - XXYYY LF  
LEAD FREE (OPTIONAL)  
SEQUENCE NUMBER  
ALWAYS 'XX'  
BASE NUMBER

② THIS PRODUCT IS CONFIGURED IN SIZES OF 6 THRU 80 COLUMNS IN INCREMENTS OF ONE. i.e.: 6,7,8,9.....79,80.

③ HOUSING MATERIAL: GLASS AND MINERAL FILLED HIGH TEMP. THERMOPLASTIC. FLAME RETARDANT PER UL94V-0. COLOR: BLACK. CONTACT MATERIAL: BeCu

④ MANUFACTURE'S NAME, PART NUMBER AND LOT CODE TO APPEAR ON THIS SURFACE PER BUS-12-108.

5. DIMENSION "A" CALCULATION = .100(2.54) x NO. OF COLUMNS + .75(19.1)  
DIMENSION "B" CALCULATION = .100(2.54) x NO. OF COLUMNS + .450(11.43)  
DIMENSION "C" CALCULATION = .100(2.54) x NO. OF COLUMNS - .100(2.54)

6. THIS PRODUCT (WITH 'LF' SUFFIX) MEETS EUROPEAN UNION DIRECTIVES AND OTHER COUNTRY REGULATIONS AS DESCRIBED IN GS-22-008. THIS HOUSING WILL WITHSTAND EXPOSURE TO 260°C PEAK TEMPERATURE FOR 10-30 SECONDS IN A CONVECTION, INFRA-RED OR VAPOR PHASE REFLOW OVEN.

⑦ FOR P/N 50576-3YYYYE (CUSTOMER ALCATEL) USE CONTACT PLATING 30μ"/0.76μ GXT

⑧ PLATING OPTIONS: MAYBE EITHER GOLD OR GXT PLATED AT MANUFACTURER CHOICE

mat'l. code		surface		tolerance		projection		product family	
NOTE 3		ISO 1302 ✓		ISO 406 ISO 1101		INCH/MM		HPC	
ltr	ecn no	dr	date	tolerances unless otherwise specified		INCH/MM		title	
AA				.XX±.01/.X±0.3		INCH/MM		4 ROW R/A RECEPTACLE	
				.XXX±.005/.XX±0.13		scale 1:1		GENERIC, MOUNT, S.T.B. 0 G.P.	
				.XXX±.0020/.XXX±0.051				dwg no	
		dr	D.SHEAFFER	1992-08-27			sheet 2 of 5		size
		enr	S.CLARK	1992-09-30			50576		A3
		chr	M. JACOB	2018-09-01			type		Product Customer Drawing
		appd	BIJU K PAUL	2018-09-01					
sheet index	revision sheet								



PRODUCT NUMBER	ITEM KEY	SIGNAL DATA			
		SIZE 4 x 20	TOTAL NO. OF POSITIONS - 80	NO. OF POSITIONS LOADED - 40	
		PLATING (NOTE 8)	QTY.	R/A RECEPTACLE STYLE	
				MATING LENGTH	TAIL LENGTH
50576-XX008	A	30u"/.76u Au	20	N/A	.125 [3.18]
	B	30u"/.76u Au	20	N/A	.125 [3.18]
	BLANK	OMIT	40	N/A	N/A
50576-XX008LF	A	30u"/.76u GXT	20	N/A	.125 [3.18]
	B	30u"/.76u GXT	20	N/A	.125 [3.18]
	BLANK	OMIT	40	N/A	N/A

50576-XX008 AND -XX008LF SHOWN ON THIS SHEET

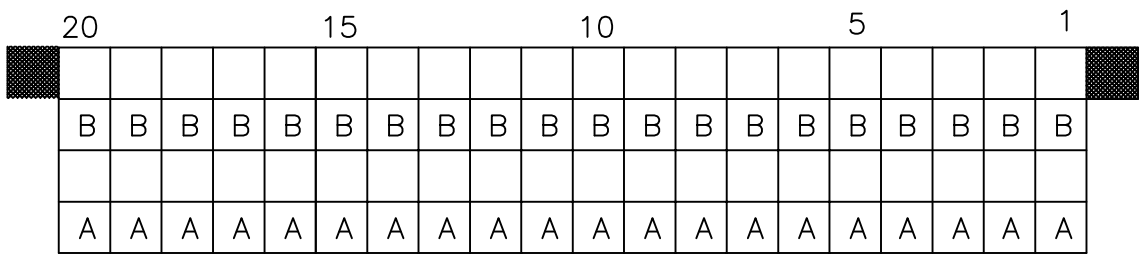

TERM.  
1

- ALL POSITIONS ARE LOADED, EXCEPT OMITTS, AS SHOWN.
- COLUMN 1, ROW A IS DESIGNATED AS SIGNAL TERM. 1, AS VIEWED FROM THE MATING FACE.

mat'l. code NOTE 3		surface ISO 1302 ✓	tolerance ISO 406 ISO 1101	projection 	product family HPC
ltr	ecn no	dr	date	tolerances unless otherwise specified	title
Y				linear .XX±.01/.X±0.3 .XXX±.005/.XX±0.13 .XXXX±.0020/.XXX±0.051	4 ROW R/A RECEPTACLE GENERIC, MOUNT, S.T.B. 0 G.P.
				angles 0°±2'	INCH/MM scale 1:1
		dr	D.SHEAFFER 1992-08-27	Amphenol FCi	dwg no 50576
		enr	S.CLARK 1992-09-30		sheet 4 of 5 size A3
		chr	M. JACOB 2012-01-09		type Product Customer Drawing
		appd	BIJU K PAUL 2012-01-09		
sheet index	revision sheet				

PRODUCT NUMBER	ITEM KEY	SIGNAL DATA			
		SIZE 4 x 20	TOTAL NO. OF POSITIONS -80	NO. OF POSITIONS LOADED - 60	
		PLATING (NOTE 8)	QTY.	R/A RECEPTACLE STYLE	
				MATING LENGTH	TAIL LENGTH
50576-XX009LF	A	30u"/.76u GXT	20	N/A	.125 [3.18]
	B	30u"/.76u GXT	20	N/A	.125 [3.18]
	C	30u"/.76u GXT	20	N/A	.125 [3.18]

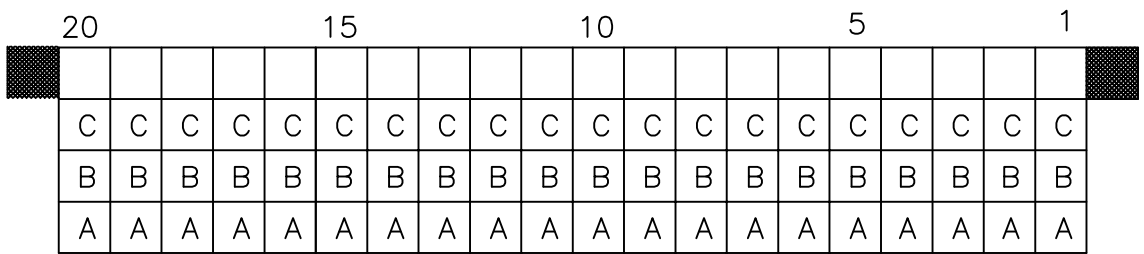

TERM.  
1

- ALL POSITIONS ARE LOADED, EXCEPT OMITTS, AS SHOWN.
- COLUMN 1, ROW A IS DESIGNATED AS SIGNAL TERM. 1, AS VIEWED FROM THE MATING FACE.

mat'l. code NOTE 3		surface ISO 1302 ✓	tolerance ISO 406 ISO 1101	projection 	product family HPC
ltr	ecn no	dr	date	tolerances unless otherwise specified	title 4 ROW R/A RECEPTACLE GENERIC, MOUNT, S.T.B. 0 G.P.
A				linear .XX±.01/.X±0.3 .XXX±.005/.XX±0.13 .XXXX±.0020/.XXX±0.051	
				angles 0°±2'	INCH/MM scale 1:1
		dr	M JACOB	2018-09-01	Amphenol FCi
		enr	M JACOB	2018-09-01	
		chr	S ALOSIUS	2018-09-01	
		appd	BIJU K PAUL	2018-09-01	
sheet index	revision sheet				dwg no 50576
					sheet 5 of 5 size A3
					type Product Customer Drawing