

## FEATURES

- 4.72 mm × 3.76 mm × 1.0 mm surface-mount package
- High SNR of 62 dBA
- Sensitivity of -42 dBV
- Flat frequency response from 100 Hz to 15 kHz
- Low current consumption of <250  $\mu$ A
- Single-ended analog output
- High PSR of 70 dB
- Compatible with Sn/Pb and Pb-free solder processes
- RoHS/WEEE compliant

## APPLICATIONS

- Smartphones and feature phones
- Teleconferencing systems
- Digital video cameras
- Bluetooth headsets
- Video phones
- Tablets

## GENERAL DESCRIPTION

The [ADMP401](#)<sup>1</sup> is a high quality, high performance, low power, analog output, bottom-ported omnidirectional MEMS microphone. The [ADMP401](#) consists of a MEMS microphone element, an impedance converter, and an output amplifier. The [ADMP401](#) sensitivity specification makes it an excellent choice for both near field and far field applications. The [ADMP401](#) has a high SNR and flat wideband frequency response, resulting in natural sound with high intelligibility. Low current consumption

enables long battery life for portable applications. The [ADMP401](#) complies with the TIA-920 standard, *Telecommunications Telephone Terminal Equipment Transmission Requirements for Wideband Digital Wireline Telephones*.

The [ADMP401](#) is available in a thin, 4.72 mm × 3.76 mm × 1.0 mm surface-mount package. It is reflow solder compatible with no sensitivity degradation. The [ADMP401](#) is halide free.

## FUNCTIONAL BLOCK DIAGRAM

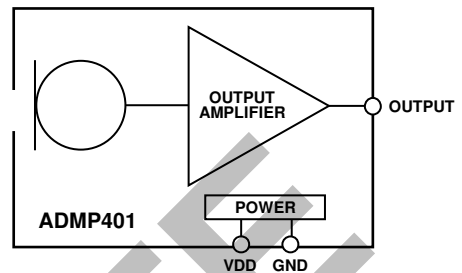

Figure 1.

07712-001

<sup>1</sup> Protected by U.S. Patents 7,449,356; 7,825,484; 7,885,423; 7,961,897. Other patents are pending.

### Rev. E

Information furnished by Analog Devices is believed to be accurate and reliable. However, no responsibility is assumed by Analog Devices for its use, nor for any infringements of patents or other rights of third parties that may result from its use. Specifications subject to change without notice. No license is granted by implication or otherwise under any patent or patent rights of Analog Devices. Trademarks and registered trademarks are the property of their respective owners.

## TABLE OF CONTENTS

Features .....	1	Connecting the ADMP401 to a Codec .....	8
Applications.....	1	Connecting the ADMP401 to an Op Amp Gain Stage .....	8
Functional Block Diagram .....	1	Supporting Documents .....	8
General Description .....	1	Handling Instructions.....	9
Revision History .....	2	Pick-and-Place Equipment .....	9
Specifications.....	3	Reflow Solder .....	9
Absolute Maximum Ratings.....	4	Board Wash .....	9
ESD Caution.....	4	Reliability Specifications.....	10
Pin Configuration and Function Descriptions.....	5	Outline Dimensions .....	11
Printed Circuit Board (PCB) Land Pattern Layout.....	6	Ordering Guide .....	11
Typical Performance Characteristics .....	7		
Applications Information .....	8		

## REVISION HISTORY

### 7/12—Rev. D to Rev. E

Changes to Features Section, General Description Section, and Page 1 Layout .....	1
Add Note 1.....	1
Changes to Frequency Response Parameter, Table 1 and Powers Supply Rejection Parameter, Table 1 .....	3
Changes to Temperature Range Parameter, Table 2.....	4
Changes to Figure 6, Figure 7, and Figure 8.....	7
Changes to Applications Information Section and Figure 10.....	8
Added Supporting Documents Section, Application Notes Section, Circuit Notes Section, and Evaluation Board User Guides Section .....	8
Changes to THB Description Column, Table 5 and Temperature Cycle Column, Table 5 .....	10
Changes to Ordering Guide .....	11

### 1/12—Rev. C to Rev. D

Updated Outline Dimensions .....	11
Changes to Figure 12.....	11
Added Figure 13.....	11
Change to Ordering Guide.....	11

### 8/11—Rev. B to Rev. C

Changes to Figure 1.....	1
Changes to Table 3.....	4
Removed Terminal Side Down from Figure 3.....	5
Changes to Bullet 2 in Pick-and-Place Equipment Section.....	9
Changes to Ordering Guide .....	11

### 12/10—Rev. A to Rev. B

Changes to Applications and General Description Sections .....	1
Changes to Table 1 .....	3

### 8/10—Rev. 0 to Rev. A

Changes to Frequency Response Parameter, Table 1.....	3
Changes to Supply Voltage Parameter, Table 2.....	4
Changes to Applications Information Section, Figure 9, and Figure 10 .....	8
Updated Outline Dimensions.....	11

### 4/10—Revision 0: Initial Version

## SPECIFICATIONS

$T_A = 25^\circ\text{C}$ ,  $V_{DD} = 1.8\text{ V}$ , unless otherwise noted. All minimum and maximum specifications are guaranteed. Typical specifications are not guaranteed.

Table 1.

Parameter	Symbol	Test Conditions/Comments	Min	Typ	Max	Unit
<b>PERFORMANCE</b>						
Directionality				Omni		
Sensitivity		1 kHz, 94 dB SPL	-45	-42	-39	dBV
Signal-to-Noise Ratio	SNR			62		dB
Equivalent Input Noise	EIN			32		dB SPL
Dynamic Range		Derived from EIN and maximum acoustic input		88		dB
Frequency Response <sup>1</sup>		Low frequency, -3 dB point		60		Hz
		High frequency, -3 dB point		15		kHz
		Deviation limits from flat response within pass band		-3/+2		dB
Total Harmonic Distortion	THD	105 dB SPL			3	%
Power Supply Rejection	PSR	217 Hz, 100 mV p-p square wave superimposed on $V_{DD} = 1.8\text{ V}$		70		dB
Maximum Acoustic Input		Peak		120		dB SPL
<b>POWER SUPPLY</b>						
Supply Voltage	$V_{DD}$		1.5		3.3	V
Supply Current	$I_S$				250	$\mu\text{A}$
<b>OUTPUT CHARACTERISTICS</b>						
Output Impedance	$Z_{OUT}$			200		$\Omega$
Output DC Offset				0.8		V
Output Current Limit				90		$\mu\text{A}$

<sup>1</sup> See Figure 6 and Figure 7.

## ABSOLUTE MAXIMUM RATINGS

Table 2.

Parameter	Rating
Supply Voltage	-0.3 V to +3.6 V
Sound Pressure Level (SPL)	160 dB
Mechanical Shock	10,000 g
Vibration	Per MIL-STD-883 Method 2007, Test Condition B
Temperature Range	-40°C to +85°C

Stresses above those listed under Absolute Maximum Ratings may cause permanent damage to the device. This is a stress rating only; functional operation of the device at these or any other conditions above those indicated in the operational section of this specification is not implied. Exposure to absolute maximum rating conditions for extended periods may affect device reliability.

## ESD CAUTION



**ESD (electrostatic discharge) sensitive device.** Charged devices and circuit boards can discharge without detection. Although this product features patented or proprietary protection circuitry, damage may occur on devices subjected to high energy ESD. Therefore, proper ESD precautions should be taken to avoid performance degradation or loss of functionality.

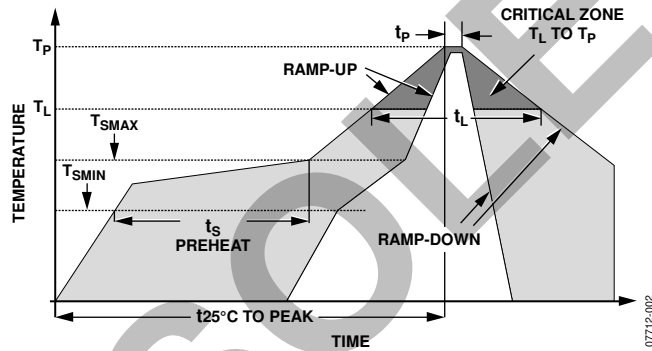

Figure 2. Recommended Soldering Profile Limits

Table 3. Recommended Soldering Profile Limits

Profile Feature	Sn-Pb	Pb Free
Average Ramp Rate ( $T_L$ to $T_P$ )	1.25°C/sec maximum	1.25°C/sec maximum
Preheat		
Minimum Temperature ( $T_{SMIN}$ )	100°C	100°C
Maximum Temperature ( $T_{SMAX}$ )	150°C	200°C
Time ( $T_{SMIN}$ to $T_{SMAX}$ ), $t_S$	60 sec to 75 sec	60 sec to 75 sec
Ramp-Up Rate ( $T_{SMAX}$ to $T_L$ )	1.25°C/sec	1.25°C/sec
Time Maintained Above Liquidous ( $t_L$ )	45 sec to 75 sec	~50 sec
Liquidous Temperature ( $T_L$ )	183°C	217°C
Peak Temperature ( $T_P$ )	215°C +3°C/-3°C	245°C +0°C/-5°C
Time Within 5°C of Actual Peak Temperature ( $t_P$ )	20 sec to 30 sec	20 sec to 30 sec
Ramp-Down Rate	3°C/sec maximum	3°C/sec maximum
Time 25°C ( $t_{25^\circ C}$ ) to Peak Temperature	5 min maximum	5 min maximum

## PIN CONFIGURATION AND FUNCTION DESCRIPTIONS

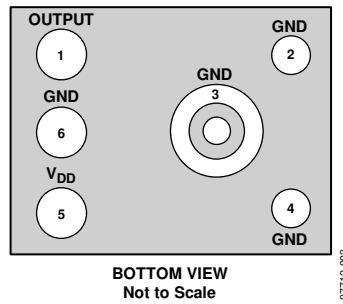

Figure 3. Pin Configuration (Bottom View)

Table 4. Pin Function Descriptions

Pin No.	Mnemonic	Description
1	OUTPUT	Analog Output Signal
2	GND	Ground
3	GND	Ground
4	GND	Ground
5	V <sub>DD</sub>	Power Supply
6	GND	Ground

## PRINTED CIRCUIT BOARD (PCB) LAND PATTERN LAYOUT

The recommended PCB land pattern for the ADMP401 should have a 1:1 ratio to the solder pads on the microphone package, as shown in Figure 4. Take care to avoid applying solder paste to the sound hole in the PCB.

A suggested solder paste stencil pattern layout is shown in Figure 5. The diameter of the sound hole in the PCB should be larger than the diameter of the sound port of the microphone. A minimum diameter of 0.5 mm is recommended.

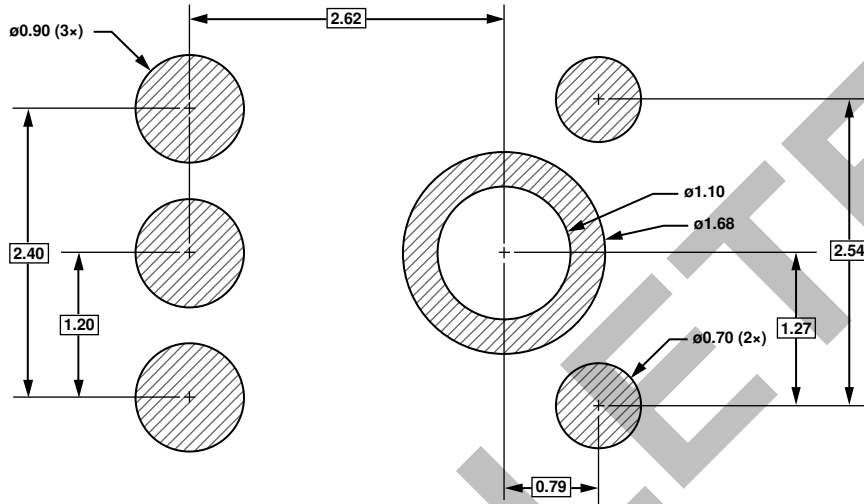

Figure 4. PCB Land Pattern Layout (Dimensions Shown in mm)

07712-004

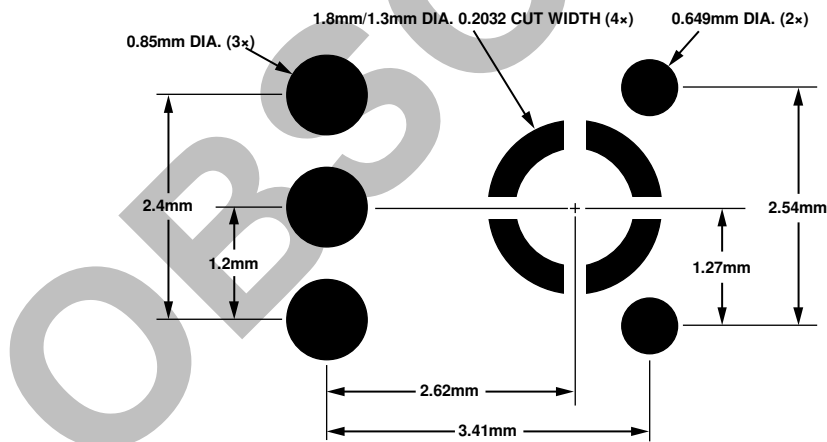

Figure 5. Suggested Solder Paste Stencil Pattern Layout

07712-005

### TYPICAL PERFORMANCE CHARACTERISTICS

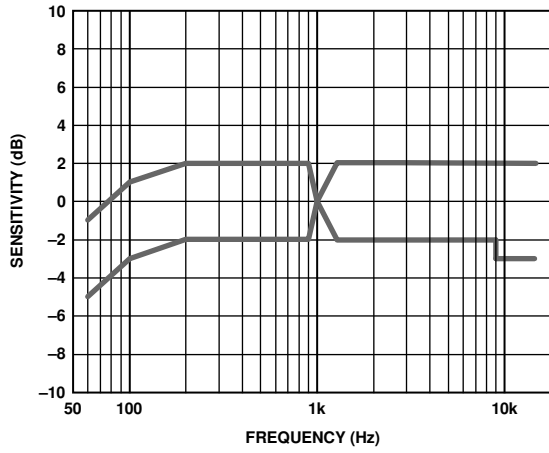

Figure 6. Frequency Response Mask

07712-006

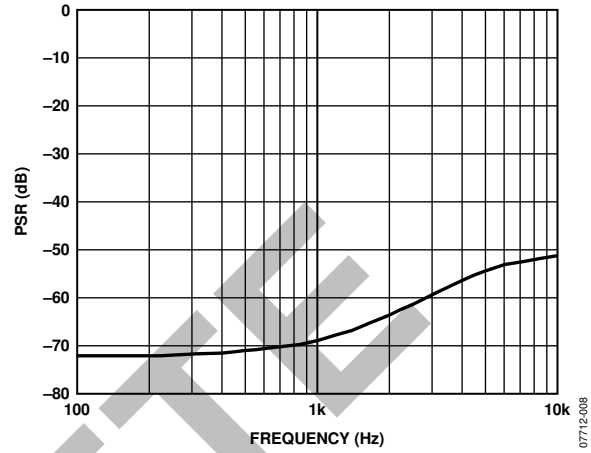

Figure 8. Typical Power Supply Rejection vs. Frequency

07712-008

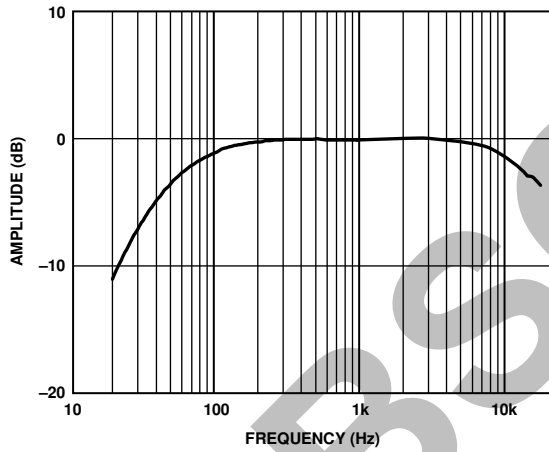

Figure 7. Typical Frequency Response (Measured)

07712-007

## APPLICATIONS INFORMATION

The ADMP401 output can be connected to a dedicated codec microphone input (see Figure 9) or to a high input impedance gain stage (see Figure 10). A 0.1  $\mu\text{F}$  ceramic capacitor placed close to the ADMP401 supply pin is used for testing and is recommended to adequately decouple the microphone from noise on the power supply. A dc-blocking capacitor is required at the output of the microphone. This capacitor creates a high-pass filter with a corner frequency at

$$f_c = 1/(2\pi \times C \times R)$$

where  $R$  is the input impedance of the codec.

A minimum value of 2.2  $\mu\text{F}$  is recommended in Figure 9 because the input impedance of the ADAU1361/ADAU1761 can be as low as 2  $\text{k}\Omega$  at its highest PGA gain setting, which results in a high-pass filter corner frequency at about 37 Hz. Figure 10 shows the ADMP401 connected to the ADA4897-1 op amp configured as a noninverting preamplifier.

### CONNECTING THE ADMP401 TO A CODEC

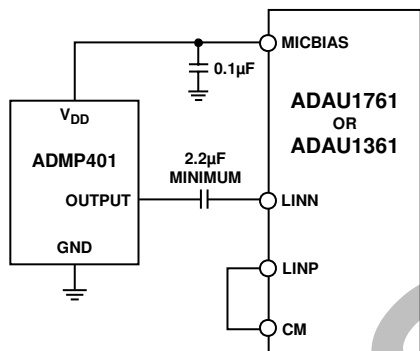

Figure 9. ADMP401 Connected to the Analog Devices ADAU1761 or ADAU1361 Codec

### CONNECTING THE ADMP401 TO AN OP AMP GAIN STAGE

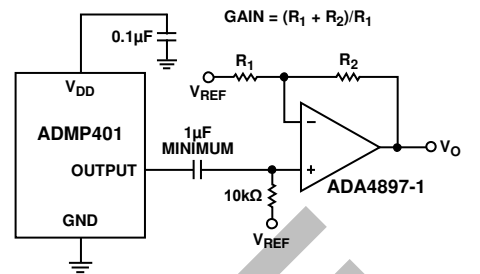

Figure 10. ADMP401 Connected to the ADA4897-1 Op Amp

## SUPPORTING DOCUMENTS

### Application Notes

[AN-1003](#), Recommendations for Mounting and Connecting Analog Devices, Inc., Bottom-Ported MEMS Microphones

[AN-1068](#), Reflow Soldering of the MEMS Microphone

[AN-1112](#), Microphone Specifications Explained

[AN-1124](#), Recommendations for Sealing Analog Devices, Inc., Bottom-Port MEMS Microphones from Dust and Liquid Ingress

[AN-1140](#), Microphone Array Beamforming

### Circuit Notes

[CN-0207](#), High Performance Analog MEMS Microphone's Simple Interface to SigmaDSP Audio Codec

[CN-0262](#), Low Noise Analog MEMS Microphone and Preamp with Compression and Noise Gating

### Evaluation Board User Guides

[UG-126](#), EVAL-ADMP401Z: Bottom-Ported Analog Output MEMS Microphone Evaluation Board

[UG-278](#), EVAL-ADMP401Z-FLEX: Bottom-Ported Analog Output MEMS Microphone Evaluation Board



## HANDLING INSTRUCTIONS

### PICK-AND-PLACE EQUIPMENT

The MEMS microphone can be handled using standard pick-and-place and chip shooting equipment. Care should be taken to avoid damage to the MEMS microphone structure as follows:

- Use a standard pickup tool to handle the microphone. Because the microphone hole is on the bottom of the package, the pickup tool can make contact with any part of the lid surface.
- Use care during pick-and-place to ensure that no high shock events above 10 kg are experienced because such events may cause damage to the microphone.
- Do not pick up the microphone with a vacuum tool that makes contact with the bottom side of the microphone.
- Do not pull air out or blow air into the microphone port.
- Do not use excessive force to place the microphone on the PCB.

### REFLOW SOLDER

For best results, the soldering profile should be in accordance with the recommendations of the manufacturer of the solder paste that is used to attach the MEMS microphone to the PCB. It is recommended that the solder reflow profile not exceed the limit conditions specified in Figure 2 and Table 3.

### BOARD WASH

When washing the PCB, ensure that water does not make contact with the microphone port. Blow-off procedures and ultrasonic cleaning must not be used.

OBSOLETE

## RELIABILITY SPECIFICATIONS

The microphone sensitivity after stress must deviate by no more than  $\pm 3$  dB from the initial value.

Table 5.

Stress Test	Description
Low Temperature Operating Life	-40°C, 500 hours, powered
High Temperature Operating Life	+125°C, 500 hours, powered
THB	+85°C/85% relative humidity, 500 hours, powered
Temperature Cycle	-40°C/+125°C, one cycle per hour, 1000 cycles
High Temperature Storage	+150°C, 500 hours
Low Temperature Storage	-40°C, 500 hours
Component CDM ESD	All pins, 0.5 kV
Component HBM ESD	All pins, 1.5 kV
Component MM ESD	All pins, 0.2 kV

OBSOLETE

### OUTLINE DIMENSIONS

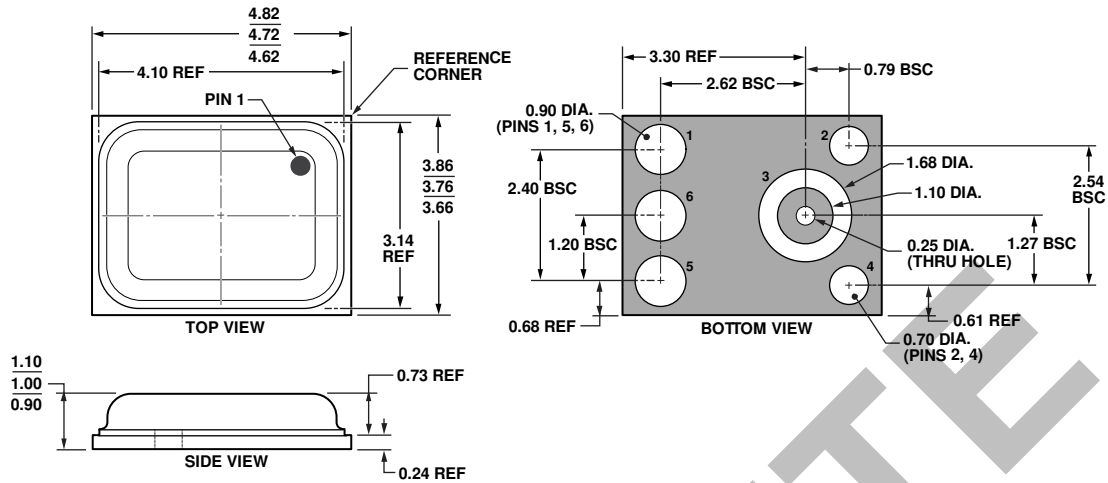

Figure 11. 6-Terminal Chip Array Small Outline No Lead Cavity [LGA\_CAV]  
 4.72 mm x 3.76 mm Body  
 (CE-6-1)  
 Dimensions shown in millimeters

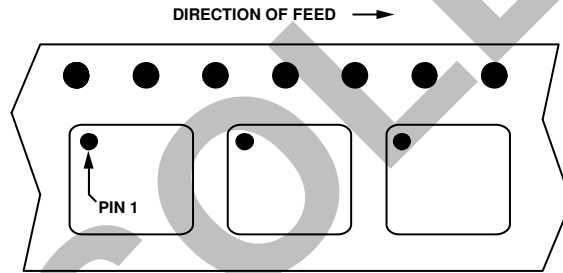

Figure 12. Microphone Orientation in Tape Until Date Code 1213

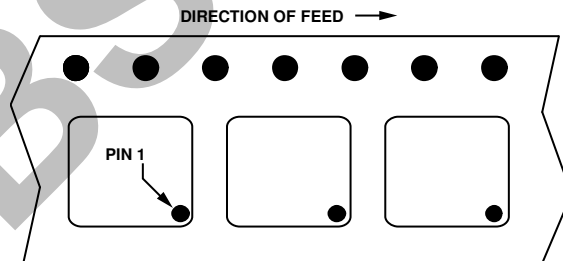

Figure 13. Microphone Orientation in Tape Starting with Date Code 1213

### ORDERING GUIDE

Model <sup>1</sup>	Temperature Range	Package Description	Package Option <sup>2</sup>	Ordering Quantity
ADMP401ACEZ-RL	-40°C to +85°C	6-Terminal LGA_CAV, 13" Tape and Reel	CE-6-1	4,500
ADMP401ACEZ-RL7	-40°C to +85°C	6-Terminal LGA_CAV, 7" Tape and Reel	CE-6-1	1,000
EVAL-ADMP401Z		Evaluation Board		
EVAL-ADMP401Z-FLEX		Evaluation Board		

<sup>1</sup> Z = RoHS Compliant Part.

<sup>2</sup> The CE-6-1 package option is halide free.

NOTES

OBSOLETE