

**STRAIGHT PLUG FULL CRIMP TYPE  
CABLE 2.6/50 D**

**R125.072.220**  
**SERIES SMA**

Hex. .315/flats  
(Hex. 8/plats)

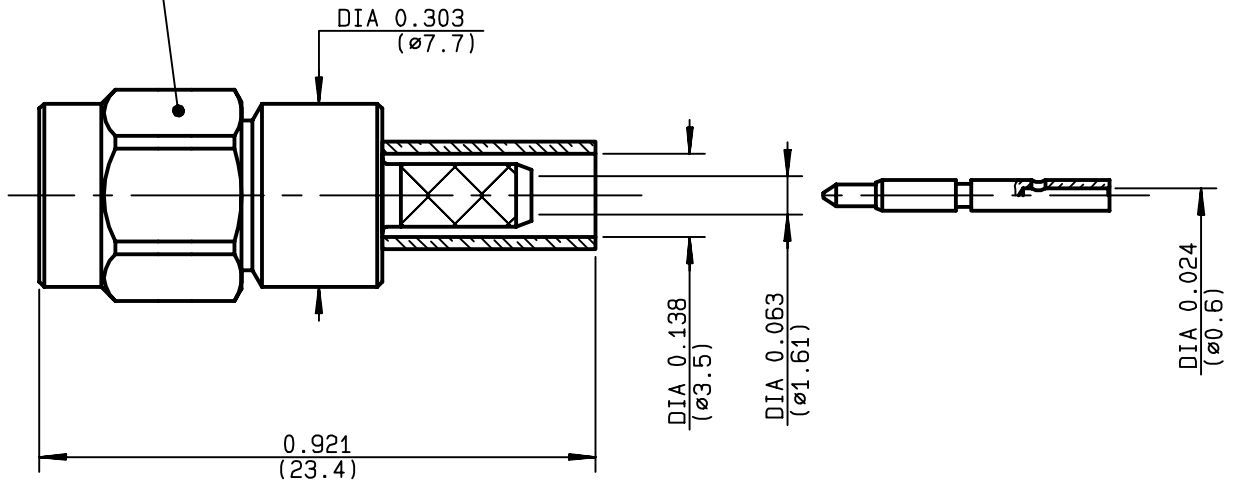

NOMINAL IMPEDANCE	<b>50</b> Ω
FREQUENCY RANGE	<b>0-12.4</b> GHz
TEMPERATURE RATING	<b>-65/+165</b> °C
V.S.W.R	<b>1.15</b> + <b>.02</b> x F(GHz)Maxi
RF INSERTION LOSS	<b>0.06</b> √F(GHz) dB Maxi
VOLTAGE RATING	<b>250</b> Veff Maxi
DIELECTRIC WITHSTANDING VOLTAGE	<b>750</b> Veff Mini
INSULATION RESISTANCE	<b>5000</b> MΩMini
HERMETIC SEAL	<b>NA</b> Atm.cm <sup>3</sup> /s
LEAKAGE (pressurized only)	<b>NA</b>
MECHANICAL DURABILITY	<b>500</b> Cycles
WEIGHT	<b>4.5</b> gr
SPECIFICATION	

CABLES : **K02252D**  
**RD 316**

OTHERS CHARACTERISTICS

CABLE RETENTION	<b>110</b> N Mini
CENTER CONTACT RETENTION	
Axial force - mating end	<b>18</b> N Mini
Axial force - opposite end	<b>18</b> N Mini
Torque	<b>NA</b> cm.N Mini
RECOMMENDED TORQUES	
Mating	<b>100</b> cm.N
Panel nut	<b>NA</b> cm.N
Clamp nut	<b>NA</b> cm.N

CONNECTOR PARTS	MATERIALS	FINISH
BODY	STAINLESS STEEL	GOLD 0.5 OVER NICKEL 2
OUTER CONTACT		
CENTER CONTACT	BRASS	GOLD 1.3 OVER NICKEL 2
INSULATOR	PTFE	-
GASKET		-
OTHERS PIECES	STAINLESS STEEL	GOLD 0.5 OVER NICKEL 2

(all values are given in micrometers)

ISSUE	CREATION DATE	FILE PART-NUMBER
<b>0143B00</b>	<b>15/10/1997</b>	<b>96-1000-047</b>



**RADIALL®**

*Connect to the future*

The information given here is subject to change without notice.  
Design changes may be in order to improve the product .



**R125.072.220**

ISSUE **0143B00** SERIES **SMA**

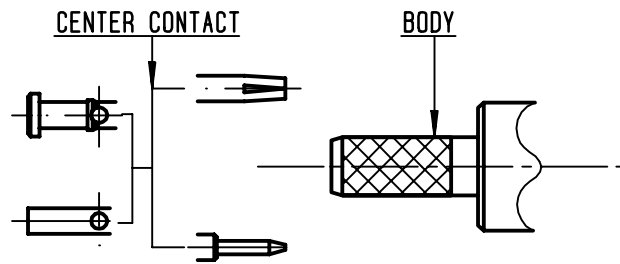
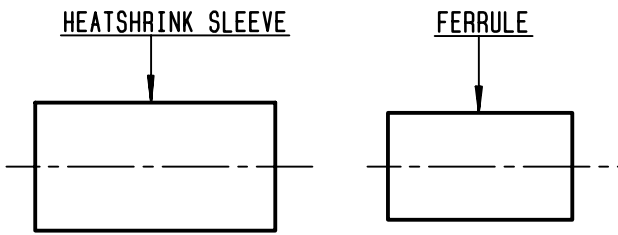

①

Slide heatshrink sleeve (R280.637.020-Option) and ferrule onto cable. Strip the cable.

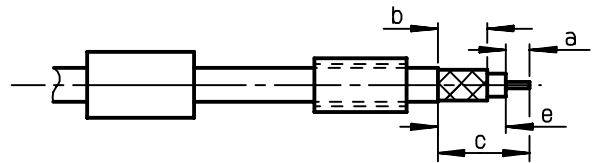

Stripping	a	b	c	d	e
inch	0.118	0.248	0.425	0	0.307
mm	3	6.3	10.8		7.8

②

Slide center contact on until it bottoms against cable dielectric. Solder or crimp center contact. Crimping tool : R282.281.000 (2 x 4 pts) position 5 + positionner R282.967.012.

SOLDER / CRIMPING

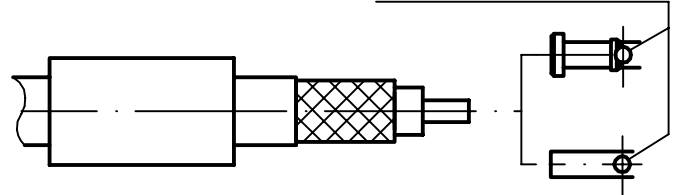

③

Fan the braid. Slide cable into the body by overtaking the insulator hard mounting point. Slide ferrule over the braid. (In direction F)

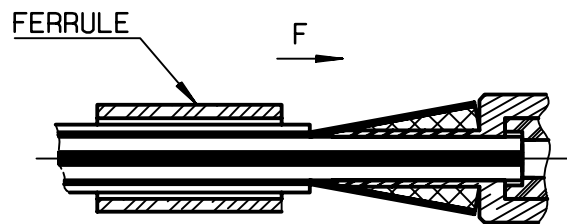

④

Crimp the ferrule with crimping tool R282.271.000 (Hex. : .151)(3.84) or crimping tool R282.293.000 (M22520/5-01) + dies R282.235.037 (M22520/5-37) Cut excess of braid if necessary. Slide sleeve over ferrule and heatshrink in place (Option)

Shrink the heatshrink sleeve

