

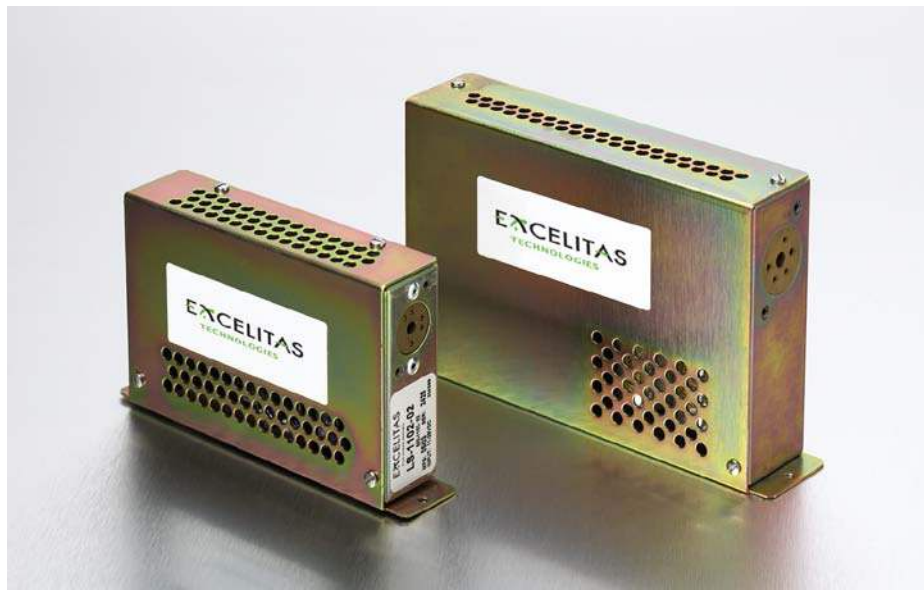

1100 Series FlashPacs



1100 Series FlashPacs from Excelsitas are ideal sources for UV-VIS-NIR applications.

1100 Series FlashPacs from Excelsitas Technologies have been designed to combine state-of-the-art circuitry and components into a packaged light source which provides microsecond-duration pulses of broadband light with exceptional arc stability. 1100 Series FlashPacs utilize the PS-1110 and PS-1120 variable output power supplies in conjunction with the appropriate Lite-Pac® trigger module to operate several types of flashlamps.

A fully shielded steel case and EMI suppression circuitry combine to diminish the radiated and conducted noise normally associated with high peak discharge currents.

FlashPacs can be ordered with a wide range of discharge capacitance values and several types of the 1100 Series flashlamps. These systems make ideal sources of pulsed light for ultraviolet-visible absorption spectroscopy, HPLC, blood analyzers, colorimetry, machine vision and ultraviolet applications.

Key Features

- Compact
- 10 or 20 Watts average power
- High radiant intensity
- Continuous spectrum UV-VIS-NIR
- User adjustable charge voltage
- Selection of flashlamps
- Selection of discharge capacitors
- Microsecond flash duration
- Simple fiber optic coupling

Applications

- Absorption analysis
- Immunoassay modules
- Fluorimetry
- Spectroradiometry
- Liquid and gas chromatography
- Colorimetry
- UV-VIS-NIR applications
- Machine vision

1100 Series FlashPacs

1100 Series FlashPacs

Electrical Inputs		
	LS-1102	LS-1130
Voltage	11-28 VDC	15-28 VDC
DC Current	1.3 Amps @ 12 VDC	1.4 Amps @ 24 VDC
Peak Current	3.5 Amps @ 12 VDC	3.5 Amps @ 24 VDC
Trigger	+5V, 20-50mA peak input, 10-100µs pulse width, leading edge trigger. Optically isolated internal series resistor = 150Ω.	
V_{ref} ($V_o/V_{ref} = 100$)	4.5 – 6.0 VDC	4-10 VDC
EMI Suppression	Yes ¹	Yes ²

¹ Inductor and filter capacitor for power input. All inputs through shielded 9-PIN "D" connector.

² Common-mode inductor and filter capacitor in power input. All inputs through shielded 9-PIN "D" connector.

Electrical Outputs (Discharge)		
	LS-1102	LS-1130
Voltage (V_o)	450-600 ± 2% VDC	400-1000 ± 2% VDC
Power Output	10 Watts max.	20 Watts max.
Charge Rate, minimum	10j/sec (12V input , 600V output)	20j/sec (24V input , 600V output)
Line Regulation	1%	
Ripple ¹	0.5%	
Internal Discharge Capacitor	0.1µF Standard. See charts following for other vaules availavble	
Recharge Delay	200µsec	

¹ Peak to peak maximum with 0.10 µF internal discharge capacitor at maximum output.

LS-1102 FlashPac Specifications			
Model Number	Discharge Capacitor	Maximum Input Energy Per Flash	Maximum Flash Rate @ 600 VDC
LS-1102-1	0.10 µF - Standard	18 mJ	550 Hz
LS-1102-2	0.22 µF	40 mJ	250 Hz
LS-1102-3	0.47 µF	85 mJ	118 Hz
LS-1102-4	1.0 µF	180 mJ	55 Hz
LS-1102-5	2.0 µF	360 mJ	28 Hz

LS-1130 FlashPac Specifications			
Model Number	Discharge Capacitor	Maximum Input Energy Per Flash	Maximum Flash Rate @ 1000 VDC
LS-1130-1	0.10 µF - Standard	50 mJ	400 Hz
LS-1130-2	0.22 µF	110 mJ	180 Hz
LS-1130-3	0.47 µF	235 mJ	85 Hz
LS-1130-4	1.0 µF	500 mJ	40 Hz

Environmental		
	LS-1102	LS-1130
Operating Temperature	+32°F to +104°F (0°C to +40°C)	
Storage Temperature	-40°F to +194°F (-40°C to +90°C)	

1100 Series FlashPacs

Mechanical Dimensions

LS-1102 Outline

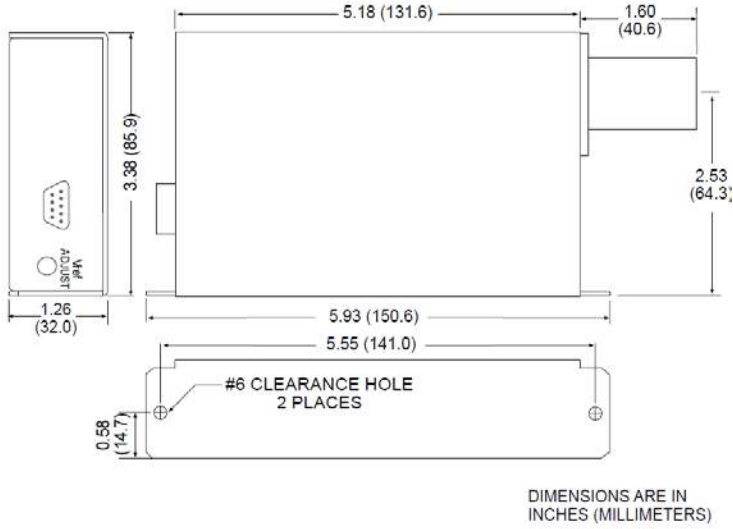

LS-1102 Optical Connector – Included with unit

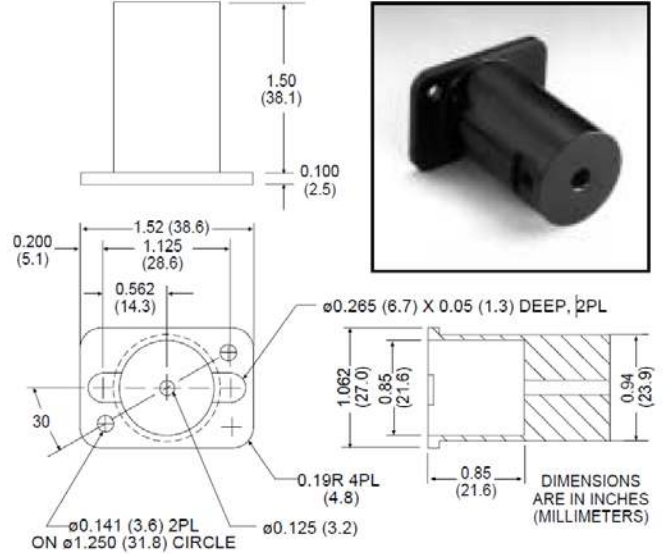

LS-1130 Outline

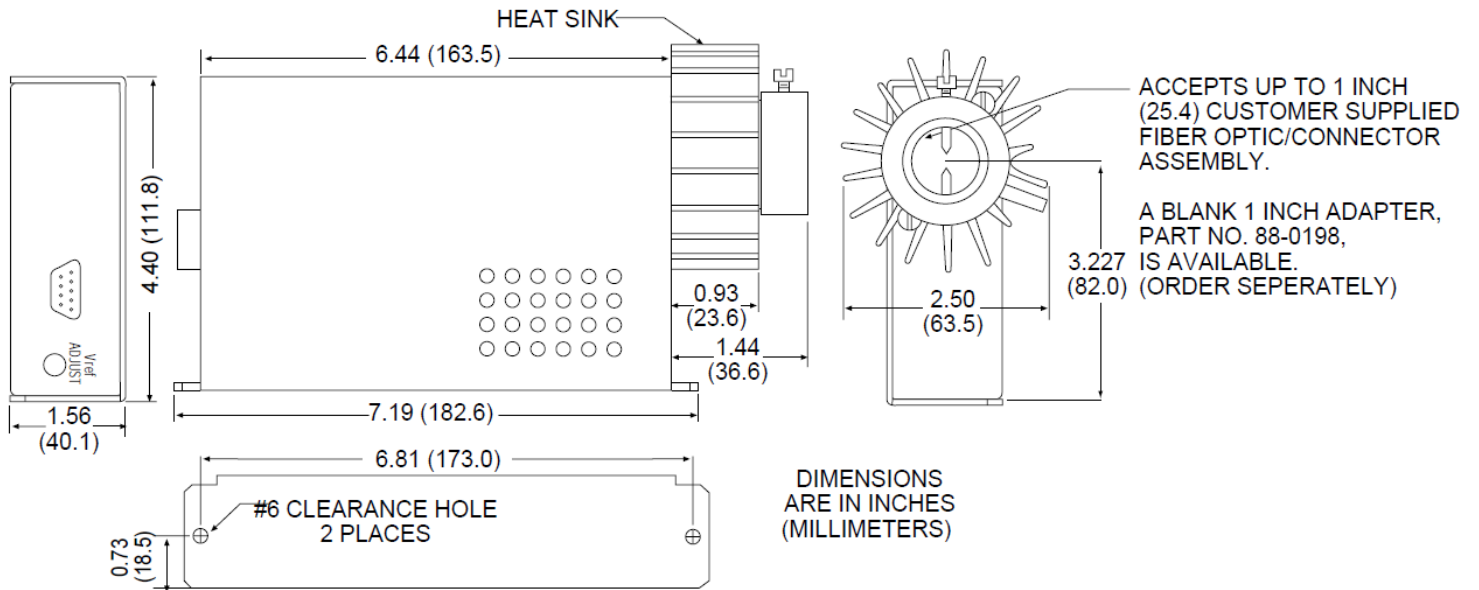

1100 Series FlashPacs

LS-1130 Heat Sink (p/n: MVS-15) – Included with unit

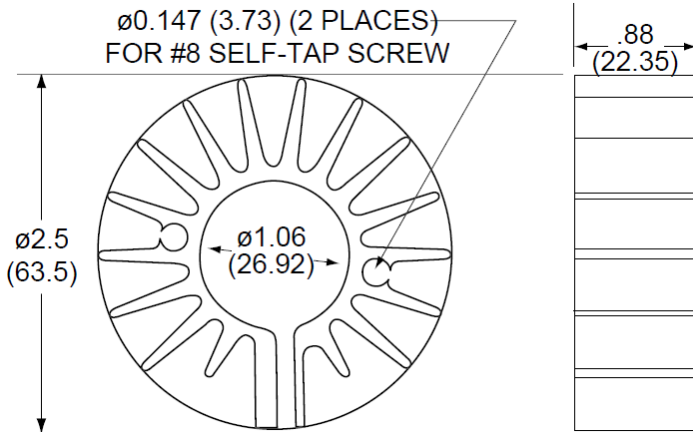

LS-1130 Optical Adapter (p/n: MVS-14-1) – Included with unit

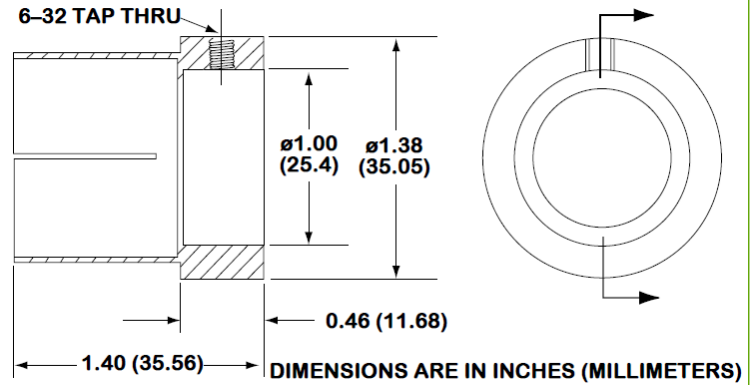

Type	Arc Length (mm)	Spectral Distribution (nm)	Window Material	Average Power (watts)	Life (flashes)	Stability
Flashlamps available for LS-1102 FlashPacs (Order flashlamps separately)						
FX-1101	1.5	225-1100+	Borosilicate	10	>1x10 ⁹	<1%CV
FX-1102		190-1100+	UV Glass			
FX-1103		120-1100+	MgF ₂			
FX-1104	3.0	225-1100+	Borosilicate	10	>1x10 ⁹	<1%CV
FX-1105		190-1100+	UV Glass			
FX-1106		120-1100+	MgF ₂			
Flashlamps available for LS-1130 FlashPacs (Order flashlamps separately)						
FX-1150	1.5	225-1100+	Borosilicate	20	>1x10 ⁹	<1%CV
FX-1151		190-1100+	UV Glass			
FX-1152		120-1100+	MgF ₂			
FX-1153	3.0	225-1100+	Borosilicate	20	>1x10 ⁹	<1%CV
FX-1154		190-1100+	UV Glass			
FX-1155		120-1100+	MgF ₂			
High output reflector flashlamps available for LS-1130 FlashPacs (Order flashlamps separately)						
FX-1160	1.5	225-1100+	Borosilicate	20	>1x10 ⁹	<1%CV
FX-1161		190-1100+	UV Glass			
FX-1162		120-1100+	MgF ₂			
FX-1163	3.0	225-1100+	Borosilicate	20	>1x10 ⁹	<1%CV
FX-1164		190-1100+	UV Glass			
FX-1165		120-1100+	MgF ₂			

**1100 Series
FlashPacs**

Spectral Distribution of Xenon Flashlamps and Window Transmittance

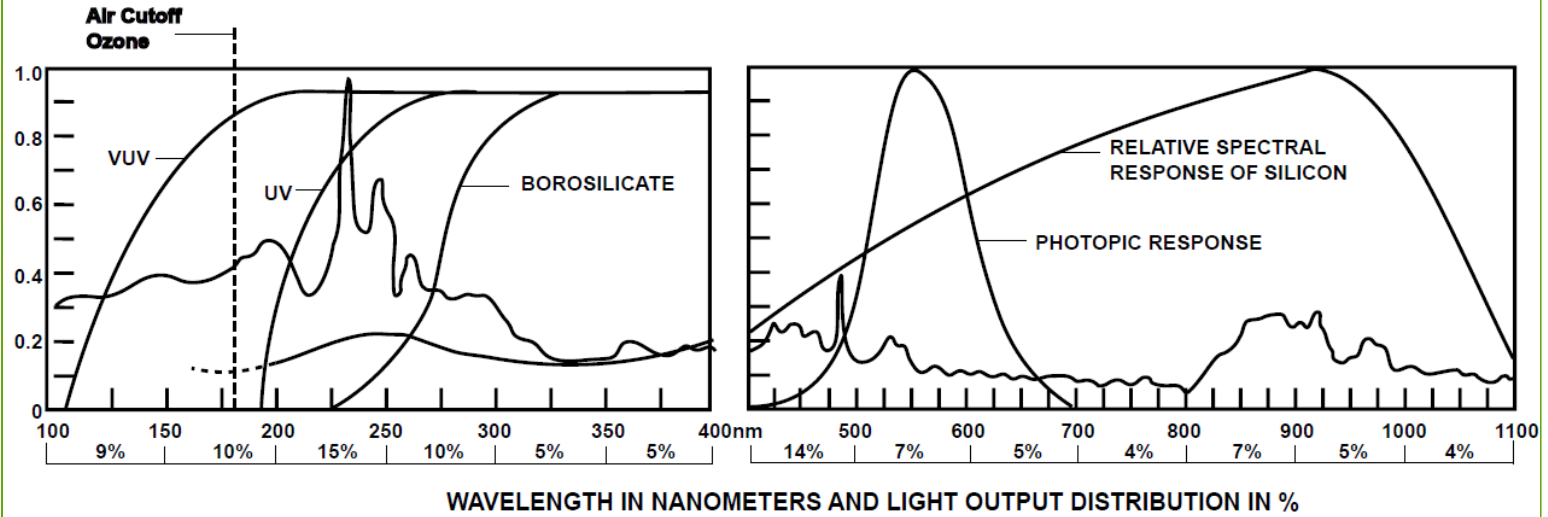

NOTE: All values are nominal; specifications subject to change without notice.

About Excelitas Technologies

Excelitas Technologies is a global technology leader focused on delivering innovative, customized solutions to meet the lighting, detection and other high-performance technology needs of OEM customers.

From medical lighting to analytical instrumentation, clinical diagnostics, industrial, safety and security, and aerospace and defense applications, Excelitas Technologies is committed to enabling our customers' success in their specialty end-markets. Excelitas Technologies has approximately 3,000 employees in North America, Europe and Asia, serving customers across the world.

Excelitas Technologies
35 Congress Street
Salem, Massachusetts
01970 USA
Telephone: (+1) 978.745.3200
Toll free: (+1) 800.950.3441
Fax: (+1) 978.745.0894

**Excelitas Technologies
LED Solutions, Inc.**
160 E. Marquardt Drive
Wheeling, Illinois
60090 USA
Telephone: (+1) 847.537.4277
Fax: (+1) 847.537.4785

**Excelitas Technologies
Illumination, Inc.**
44370 Christy Street
Fremont, California
94538-3180 USA
Telephone: (+1) 510.979.6500
Toll-free: (+1) 800.775.6786
Fax: (+1) 510.687.1140

**Excelitas Technologies
Elcos GmbH**
Luitpoldstrasse 6
Pfaffenhofen, 85276
Germany
Telephone: (+49) 8441.8917.0
Fax: (+49) 8441.7191.0

**Excelitas Technologies Shenzhen Co., Ltd.
Wearnes Technology Center**
No.10 Kefa Road, Science & Industry Park
Nanshan District,
Shenzhen, Guangdong
P.R. of China 518057
Telephone: +86 2655 3861
Fax: +86 755 2661 7311

For a complete listing of our global offices, visit www.excelitas.com/ContactUs

© 2011 Excelitas Technologies Corp. All rights reserved. The Excelitas logo and design are registered trademarks of Excelitas Technologies Corp. All other trademarks not owned by Excelitas Technologies or its subsidiaries that are depicted herein are the property of their respective owners. Excelitas reserves the right to change this document at any time without notice and disclaims liability for editorial, pictorial or typographical errors.

