

CKT. SIZE	DIM. "A"		DIM. "B"	
	MM	IN.	MM	IN.
2	2.54	.100	5.33±0.08	.210±.003
3	5.08	.200	8.13±0.10	.320±.004
4	7.62	.300	10.67±0.10	.420±.004
5	10.16	.400	13.21±0.10	.520±.004
6	12.70	.500	15.75±0.10	.620±.004
7	15.24	.600	18.29±0.10	.720±.004
8	17.78	.700	20.83±0.10	.820±.004
9	20.32	.800	23.37±0.10	.920±.004
10	22.86	.900	25.91±0.13	1.020±.005
11	25.40	1.000	28.45±0.13	1.120±.005
12	27.94	1.100	30.99±0.13	1.220±.005
13	30.48	1.200	33.53±0.13	1.320±.005
14	33.02	1.300	36.07±0.13	1.420±.005
15	35.56	1.400	38.61±0.15	1.520±.006
16	38.10	1.500	41.15±0.15	1.620±.006
17	40.64	1.600	43.69±0.15	1.720±.006
18	43.18	1.700	46.23±0.15	1.820±.006
19	45.72	1.800	48.77±0.18	1.920±.007
20	48.26	1.900	51.31±0.18	2.020±.007
21	50.80	2.000	53.85±0.18	2.120±.007
22	53.34	2.100	56.39±0.18	2.220±.007
23	55.88	2.200	58.93±0.18	2.320±.007
24	58.42	2.300	61.47±0.18	2.420±.007
25	60.96	2.400	64.01±0.20	2.520±.008

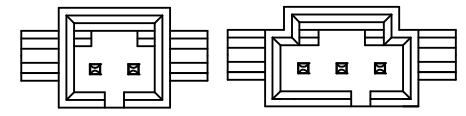
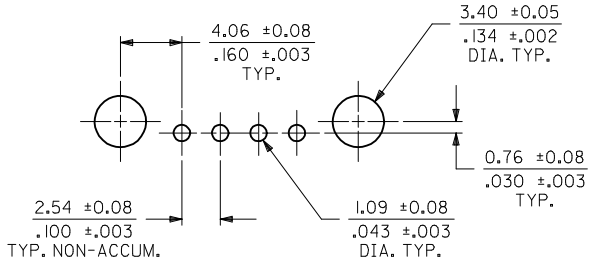
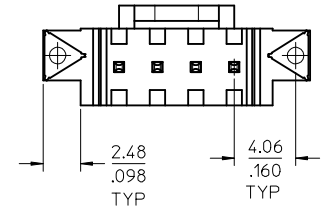
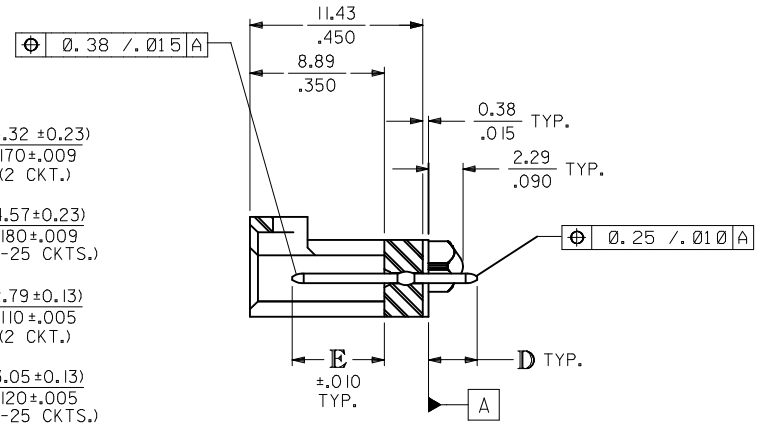
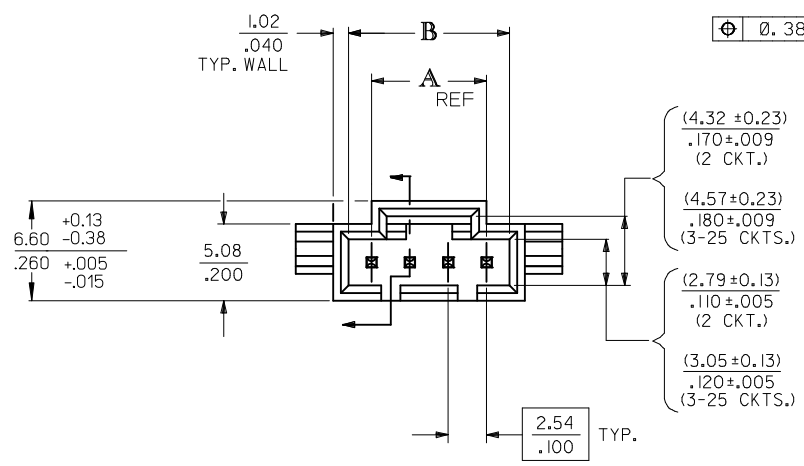

RECOMMENDED PC BOARD LAYOUT
(FOR USE WITH 1.57 / .062 THICK BOARD)

- NOTES:
1. HEADER MATERIAL: GLASS FILLED POLYESTER, UL94V-0; COLOR: BLACK
PIN MATERIAL: PHOSPHOR BRONZE
 2. FINISH:
TIN - 0.00381/.000150 MIN TIN PLATE
OVER 0.00127/.000050 MIN NICKEL PLATE
15 GOLD - 0.00038/.000015 MIN GOLD PLATE IN SELECT AREA,
0.00191/.000075 MIN TIN PLATE IN SELECT AREA,
OVER 0.00127/.000050 MIN NICKEL PLATE OVERALL.
30 GOLD - 0.00076/.000030 MIN GOLD PLATE IN SELECT AREA,
0.00191/.000075 MIN TIN PLATE IN SELECT AREA,
OVER 0.00127/.000050 MIN NICKEL PLATE OVERALL.
* THE PRIMARY SHIPPING CARTON WILL BE LABELED "COMPLIANT TO RoHS
DIRECTIVE 2002/95/EC AND ELV ANNEX II OF DIRECTIVE 2000/53/EC."
CARTONS WITHOUT THIS LABEL MAY CONTAIN PRODUCT WITH LEAD.
 3. PRODUCT SPECIFICATION: PS-70541
 4. PACKAGING SPECIFICATION: PK-70873-0014
 5. HEADER TO BE USED WITH OPTION "G" 70400 AND 70430 SERIES SL CONNECTORS.

ADD .098 AND .160 EC NO: UCP2017-1091 DRWINKSMIEC 2016/11/11 CHKD: APPR:FSMITH 2016/12/29	QUALITY SYMBOLS ▽=0 ▽=0 ▽=0	GENERAL TOLERANCES (UNLESS SPECIFIED)	DIMENSION STYLE		SCALE 4:1	DESIGN UNITS INCH	THIRD ANGLE PROJECTION
			mm	INCH			
M	DESCRIPTION	DRAFT WHERE APPLICABLE MUST REMAIN WITHIN DIMENSIONS	MM/IN		DRAWN BY AAB DATE 05/12/93	CHECKED BY MJM DATE 05/12/93	TITLE SALES ASSY, SL VERTICAL HEADER W/LATCH&TRI-PEGS (2.54)/.100 CENTERS
			4 PLACES ± --- ± ---	3 PLACES ± --- ± .005			
ANGULAR ±1/2°			SEE TABLE		DOCUMENT NO. SDA-70545-****		SHEET NO. 1 OF 4
THIS DRAWING CONTAINS INFORMATION THAT IS PROPRIETARY TO MOLEX INCORPORATED AND SHOULD NOT BE USED WITHOUT WRITTEN PERMISSION							

OPTIONAL HOUSING

WEBBED KEYING FEATURES

20 CKT HEADER
SHOWN FOR REFERENCE

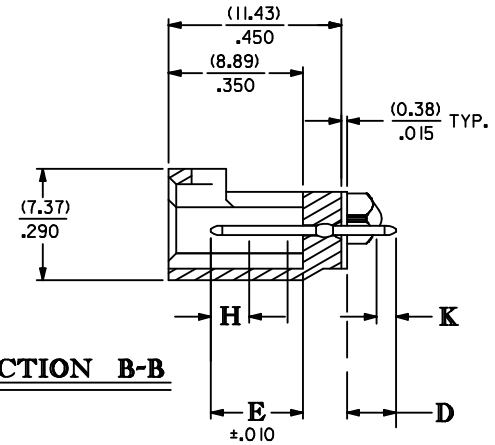
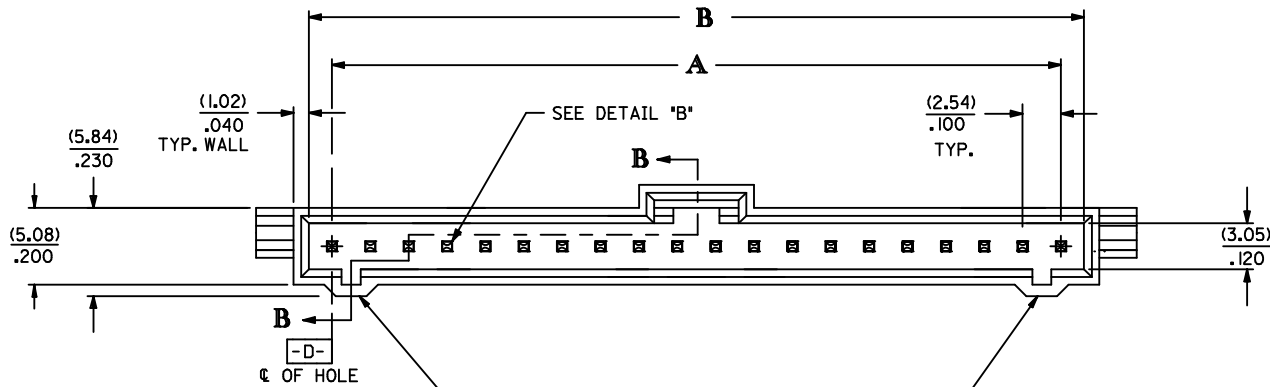
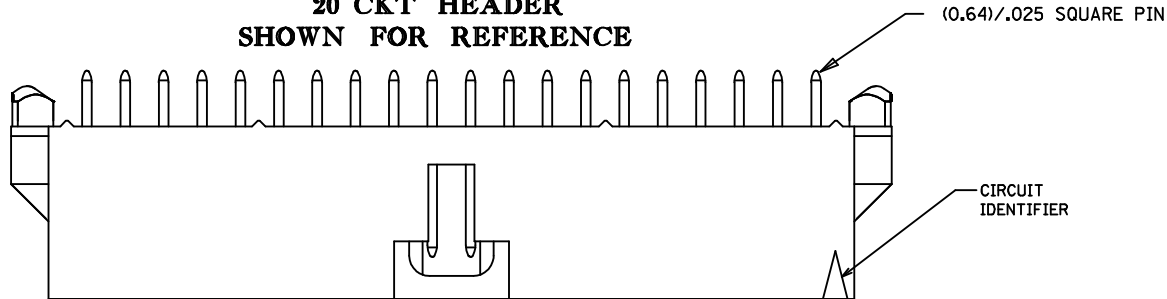

WEBBED KEYING FEATURES

SECTION B-B

SEE SHEET 1 EC NO: UCP2017-1091 DRW:KSM/IEC 2016/11/11 CHKD: APPR:FSM/TH 2016/12/29 M	QUALITY SYMBOLS	GENERAL TOLERANCES (UNLESS SPECIFIED)	DIMENSION STYLE	SCALE	DESIGN UNITS	THIRD ANGLE PROJECTION
	▽=0	mm INCH	MM/IN	INCH	INCH	
	▽=0	4 PLACES ± --- ± ---	DRAWN BY DATE	TITLE		
	▽=0	3 PLACES ± --- ±.005	AAB 05/12/93	SALES ASSY, SL VERTICAL HEADER W/LATCH&TRI-PEGS (2.54)/.100 CENTERS		
		2 PLACES ± 0.13 ±.01	CHECKED BY DATE			
		1 PLACE ± 0.25 ± ---	MJM 05/12/93			
		0 PLACE ± --- ± ---	APPROVED BY DATE			
			SMILLER 2013/07/22			
		ANGULAR ±1/2°	MATERIAL NO.	DOCUMENT NO.		
		DRAFT WHERE APPLICABLE MUST REMAIN WITHIN DIMENSIONS	SEE TABLE	SDA-70545-****		
			SIZE C			
			THIS DRAWING CONTAINS INFORMATION THAT IS PROPRIETARY TO MOLEX INCORPORATED AND SHOULD NOT BE USED WITHOUT WRITTEN PERMISSION			

CIRCUIT SIZE	ASSEMBLY ITEM NUMBER 70545		D (± 0.38) ± .015	E (± 0.25) ± .010	MATING AREA FINISH	PC TAIL AREA FINISH
2-10	-0001-0009		(3.30) .130	(6.10) .240	TIN	TIN
11-25	-0010-0024		(3.30) .130	(6.10) .240	TIN	TIN
2-10	-0036-0044		(3.30) .130	(6.10) .240	15 GOLD	TIN
11-25	-0045-0059		(3.30) .130	(6.10) .240	15 GOLD	TIN
2-10	-0071-0079		(3.30) .130	(6.10) .240	30 GOLD	TIN
11-25	-0080-0094		(3.30) .130	(6.10) .240	30 GOLD	TIN
2-10	-0141-0149		(5.21) .205	(6.10) .240	15 GOLD	TIN
11-25	-0150-0164		(5.21) .205	(6.10) .240	15 GOLD	TIN
2-10	-0176-0184		(5.21) .205	(6.10) .240	30 GOLD	TIN
11-25	-0185-0199		(5.21) .205	(6.10) .240	30 GOLD	TIN

CIRCUIT SIZE	ASSEMBLY ITEM NUMBER	ASSEMBLY ITEM NUMBER	ASSEMBLY ITEM NUMBER	ASSEMBLY ITEM NUMBER	ASSEMBLY ITEM NUMBER
2	70545-0001	70545-0036	70545-0071	70545-0141	70545-0176
3	70545-0002	70545-0037	70545-0072	70545-0142	70545-0177
4	70545-0003	70545-0038	70545-0073	70545-0143	70545-0178
5	70545-0004	70545-0039	70545-0074	70545-0144	70545-0179
6	70545-0005	70545-0040	70545-0075	70545-0145	70545-0180
7	70545-0006	70545-0041	70545-0076	70545-0146	70545-0181
8	70545-0007	70545-0042	70545-0077	70545-0147	70545-0182
9	70545-0008	70545-0043	70545-0078	70545-0148	70545-0183
10	70545-0009	70545-0044	70545-0079	70545-0149	70545-0184
11	70545-0010	70545-0045	70545-0080		
12	70545-0011	70545-0046	70545-0081		
13	70545-0012	70545-0047	70545-0082		
14	70545-0013	70545-0048	70545-0083		
15	70545-0014	70545-0049	70545-0084		
16	70545-0015	70545-0050	70545-0085		
17	70545-0016	70545-0051	70545-0086		
18	70545-0017	70545-0052	70545-0087		
19	70545-0018	70545-0053	70545-0088		
20	70545-0019	70545-0054	70545-0089		
21	70545-0020	70545-0055	70545-0090		
22	70545-0021	70545-0056	70545-0091		
23	70545-0022	70545-0057	70545-0092		
24	70545-0023	70545-0058	70545-0093		
25	70545-0024	70545-0059	70545-0094		

SEE SHEET 1 EC NO: UCP2017-1091 DRWNG:SMIEC 2016/11/11 CHKD: APPR:FSMITH 2016/12/29 DESCRIPTION REV	QUALITY SYMBOLS	GENERAL TOLERANCES (UNLESS SPECIFIED)	DIMENSION STYLE MM/IN		SCALE	DESIGN UNITS INCH	THIRD ANGLE PROJECTION
	▽=0	4 PLACES ± --- ± ---	mm	INCH	DRAWN BY AAB	DATE 05/12/93	TITLE SALES ASSY, SL VERTICAL HEADER W/LATCH&TRI-PEGS (2.54)/.100 CENTERS molex
	▽=0	3 PLACES ± --- ± .005			CHECKED BY MJM	DATE 05/12/93	
	▽=0	2 PLACES ± 0.13 ± .01			APPROVED BY SMILLER	DATE 2013/07/22	DOCUMENT NO. SDA-70545-****
	1 PLACE ± 0.25 ± ---	ANGULAR ±1/2°	SEE TABLE		SHEET NO. 3 OF 4		
	0 PLACE ± --- ± ---	DRAFT WHERE APPLICABLE MUST REMAIN WITHIN DIMENSIONS	THIS DRAWING CONTAINS INFORMATION THAT IS PROPRIETARY TO MOLEX INCORPORATED AND SHOULD NOT BE USED WITHOUT WRITTEN PERMISSION				

CIRCUIT SIZE	ASSEMBLY ITEM NUMBER 70545		D REF.	E ± .010	MATING AREA FINISH	PC TAIL AREA FINISH
2-19	-3001-3018	WEBBED ASSEMBLY	(3.30) .130	(6.10) .240	30 GOLD	TIN
20-25	-3019-3024	WEBBED ASSEMBLY	(3.30) .130	(6.10) .240	30 GOLD	TIN
2-19	-3051-3068	WEBBED ASSEMBLY	(3.30) .130	(6.10) .240	15 GOLD	TIN
20-25	-3069-3074	WEBBED ASSEMBLY	(3.30) .130	(6.10) .240	15 GOLD	TIN
2-19	-3101-3118	WEBBED ASSEMBLY	(3.30) .130	(6.10) .240	TIN	TIN
20-25	-3119-3124	WEBBED ASSEMBLY	(3.30) .130	(6.10) .240	TIN	TIN

CIRCUIT SIZE	WEBBED ASSEMBLY ITEM NUMBER	WEBBED ASSEMBLY ITEM NUMBER	WEBBED ASSEMBLY ITEM NUMBER
2			
3			
4			
5			
6			
7			
8			
9			
10			
11			
12			
13			
14			
15			
16			
17			
18			
19			
20	70545-3019	70545-3069	70545-3119
21	70545-3020	70545-3070	70545-3120
22	70545-3021	70545-3071	70545-3121
23	70545-3022	70545-3072	70545-3122
24	70545-3023	70545-3073	70545-3123
25	70545-3024	70545-3074	70545-3124

SEE SHEET 1 EC NO: UCP2017-1091 DRINKSMIEC 2016/11/11 CHKD: APPR:FSM/TH 2016/12/29 M	DESCRIPTION QUALITY SYMBOLS □=0 □=0 □=0	GENERAL TOLERANCES (UNLESS SPECIFIED)		DIMENSION STYLE MM/IN		SCALE	DESIGN UNITS INCH	THIRD ANGLE PROJECTION		
		4 PLACES ± --- ± --- 3 PLACES ± --- ± .005 2 PLACES ± 0.13 ± .01 1 PLACE ± 0.25 ± --- 0 PLACE ± --- ± ---		DRAWN BY DATE AAB 05/12/93		TITLE SALES ASSY, SL VERTICAL HEADER W/LATCH&TRI-PEGS (2.54)X.100 CENTERS		molex		SHEET NO. 4 OF 4
		ANGULAR ±1/2°		CHECKED BY DATE MJM 05/12/93		APPROVED BY DATE SMILLER 2013/07/22				
		DRAFT WHERE APPLICABLE MUST REMAIN WITHIN DIMENSIONS		MATERIAL NO. SEE TABLE		DOCUMENT NO. SDA-70545-****				

THIS DRAWING CONTAINS INFORMATION THAT IS PROPRIETARY TO MOLEX. INCORPORATED AND SHOULD NOT BE USED WITHOUT WRITTEN PERMISSION

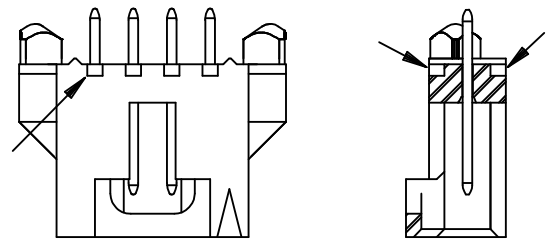
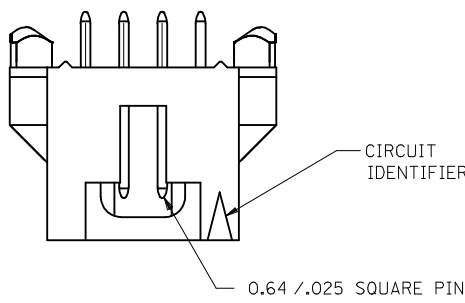

**ALTERNATIVE CORING
MANUFACTURER'S OPTION**

CKT. SIZE	DIM. "A"		DIM. "B"	
	MM	IN.	MM	IN.
2	2.54	.100	5.33±0.08	.210±.003
3	5.08	.200	8.13±0.10	.320±.004
4	7.62	.300	10.67±0.10	.420±.004
5	10.16	.400	13.21±0.10	.520±.004
6	12.70	.500	15.75±0.10	.620±.004
7	15.24	.600	18.29±0.10	.720±.004
8	17.78	.700	20.83±0.10	.820±.004
9	20.32	.800	23.37±0.10	.920±.004
10	22.86	.900	25.91±0.13	1.020±.005
11	25.40	1.000	28.45±0.13	1.120±.005
12	27.94	1.100	30.99±0.13	1.220±.005
13	30.48	1.200	33.53±0.13	1.320±.005
14	33.02	1.300	36.07±0.13	1.420±.005
15	35.56	1.400	38.61±0.15	1.520±.006
16	38.10	1.500	41.15±0.15	1.620±.006
17	40.64	1.600	43.69±0.15	1.720±.006
18	43.18	1.700	46.23±0.15	1.820±.006
19	45.72	1.800	48.77±0.18	1.920±.007
20	48.26	1.900	51.31±0.18	2.020±.007
21	50.80	2.000	53.85±0.18	2.120±.007
22	53.34	2.100	56.39±0.18	2.220±.007
23	55.88	2.200	58.93±0.18	2.320±.007
24	58.42	2.300	61.47±0.18	2.420±.007
25	60.96	2.400	64.01±0.20	2.520±.008

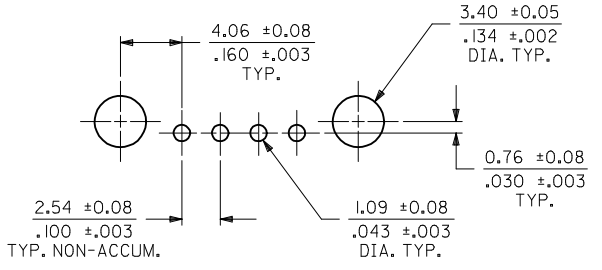
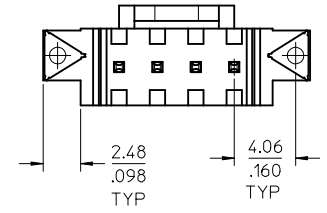
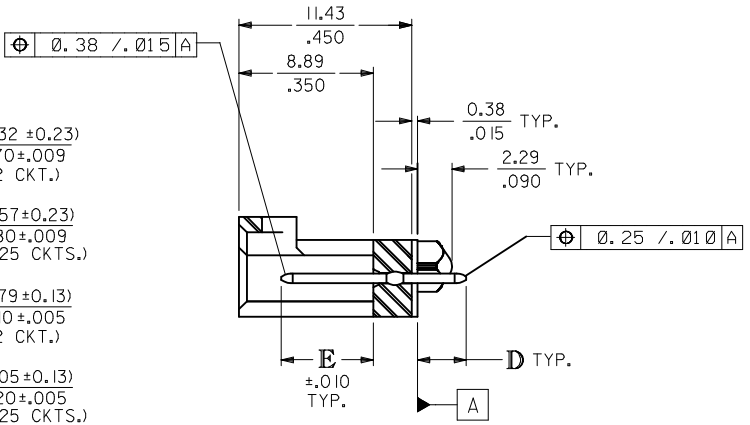
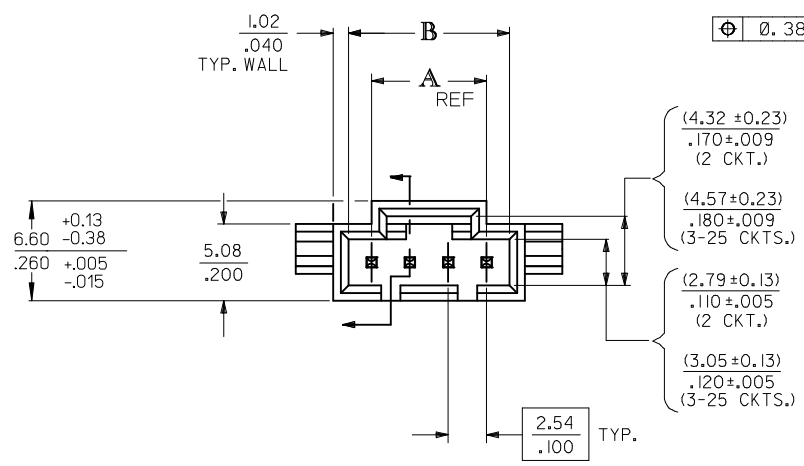

RECOMMENDED PC BOARD LAYOUT
(FOR USE WITH 1.57 / .062 THICK BOARD)

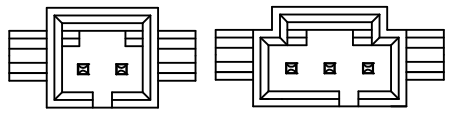

2 CIRCUIT **3 CIRCUIT**

- NOTES:
1. HEADER MATERIAL: GLASS FILLED POLYESTER, UL94V-0; COLOR: BLACK
PIN MATERIAL: PHOSPHOR BRONZE
 2. FINISH:
TIN - 0.00381/.000150 MIN TIN PLATE
OVER 0.00127/.000050 MIN NICKEL PLATE
15 GOLD - 0.00038/.000015 MIN GOLD PLATE IN SELECT AREA,
0.00191/.000075 MIN TIN PLATE IN SELECT AREA,
OVER 0.00127/.000050 MIN NICKEL PLATE OVERALL.
30 GOLD - 0.00076/.000030 MIN GOLD PLATE IN SELECT AREA,
0.00191/.000075 MIN TIN PLATE IN SELECT AREA,
OVER 0.00127/.000050 MIN NICKEL PLATE OVERALL.
* THE PRIMARY SHIPPING CARTON WILL BE LABELED "COMPLIANT TO RoHS
DIRECTIVE 2002/95/EC AND ELV ANNEX II OF DIRECTIVE 2000/53/EC."
CARTONS WITHOUT THIS LABEL MAY CONTAIN PRODUCT WITH LEAD.
 3. PRODUCT SPECIFICATION: PS-70541
 4. PACKAGING SPECIFICATION: PK-70873-0014
 5. HEADER TO BE USED WITH OPTION "G" 70400 AND 70430 SERIES SL CONNECTORS.

ADD .098 AND .160 EC NO: UCP2017-1091 DRWINKSMIEC 2016/11/11 CHKD: APPR:FSMITH 2016/12/29	QUALITY SYMBOLS ▽=0 ▽=0 ▽=0	GENERAL TOLERANCES (UNLESS SPECIFIED)	DIMENSION STYLE		SCALE	DESIGN UNITS	THIRD ANGLE PROJECTION
			mm	INCH			
M	DESCRIPTION	DRAWN BY	DATE		TITLE	DOCUMENT NO.	SHEET NO.
			AAB	05/12/93			
M	DESCRIPTION	CHECKED BY	DATE		MATERIAL NO.	SDA-70545-****	THIS DRAWING CONTAINS INFORMATION THAT IS PROPRIETARY TO MOLEX INCORPORATED AND SHOULD NOT BE USED WITHOUT WRITTEN PERMISSION
			MJM	05/12/93			
M	DESCRIPTION	APPROVED BY	DATE		SIZE	C	
			SMILLER	2013/07/22			

OPTIONAL HOUSING

WEBBED KEYING FEATURES

20 CKT HEADER SHOWN FOR REFERENCE

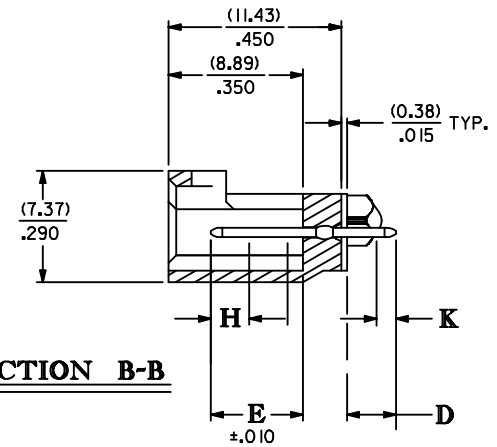
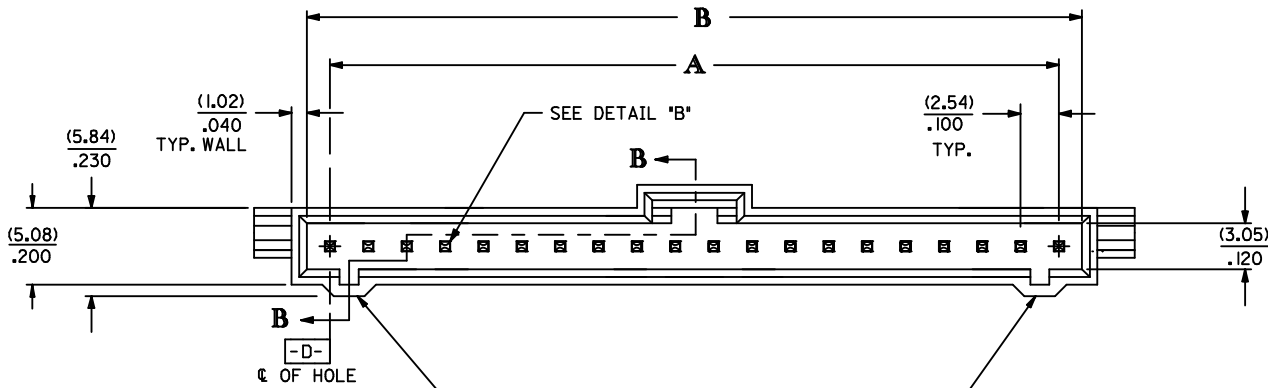
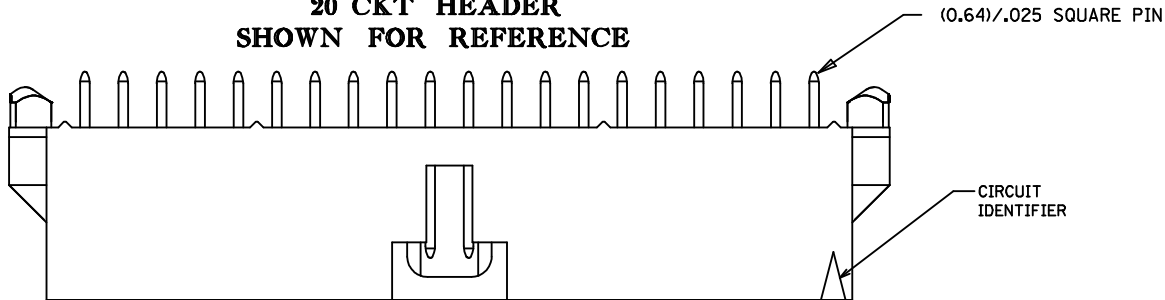

SEE SHEET 1 EC NO: UCP2017-1091 DRW:KSM/IEC 2016/11/11 CHKD: APPR:FSM/TH 2016/12/29 REV: M	QUALITY SYMBOLS	GENERAL TOLERANCES (UNLESS SPECIFIED)	DIMENSION STYLE	SCALE	DESIGN UNITS	THIRD ANGLE PROJECTION
			MM/IN	INCH	INCH	
			mm INCH	DRAWN BY DATE	TITLE	SALES ASSY, SL VERTICAL HEADER W/LATCH&TRI-PEGS (2.54) / .100 CENTERS molex
			4 PLACES ± --- ± ---	AAB 05/12/93	CHECKED BY DATE	
		3 PLACES ± --- ± .005	MJM 05/12/93	APPROVED BY DATE		
		2 PLACES ± 0.13 ± .01	SMILLER 2013/07/22	MATERIAL NO.	DOCUMENT NO.	SHEET NO.
		1 PLACE ± 0.25 ± ---		SEE TABLE	SDA-70545-****	2 OF 4
		0 PLACE ± --- ± ---		THIS DRAWING CONTAINS INFORMATION THAT IS PROPRIETARY TO MOLEX INCORPORATED AND SHOULD NOT BE USED WITHOUT WRITTEN PERMISSION		
		ANGULAR ±1/2°				
		DRAFT WHERE APPLICABLE MUST REMAIN WITHIN DIMENSIONS				

CIRCUIT SIZE	ASSEMBLY ITEM NUMBER 70545		D (± 0.38) ± .015	E (± 0.25) ± .010	MATING AREA FINISH	PC TAIL AREA FINISH
2-10	-0001-0009		(3.30) .130	(6.10) .240	TIN	TIN
11-25	-0010-0024		(3.30) .130	(6.10) .240	TIN	TIN
2-10	-0036-0044		(3.30) .130	(6.10) .240	15 GOLD	TIN
11-25	-0045-0059		(3.30) .130	(6.10) .240	15 GOLD	TIN
2-10	-0071-0079		(3.30) .130	(6.10) .240	30 GOLD	TIN
11-25	-0080-0094		(3.30) .130	(6.10) .240	30 GOLD	TIN
2-10	-0141-0149		(5.21) .205	(6.10) .240	15 GOLD	TIN
11-25	-0150-0164		(5.21) .205	(6.10) .240	15 GOLD	TIN
2-10	-0176-0184		(5.21) .205	(6.10) .240	30 GOLD	TIN
11-25	-0185-0199		(5.21) .205	(6.10) .240	30 GOLD	TIN

CIRCUIT SIZE	ASSEMBLY ITEM NUMBER	ASSEMBLY ITEM NUMBER	ASSEMBLY ITEM NUMBER	ASSEMBLY ITEM NUMBER	ASSEMBLY ITEM NUMBER
2	70545-0001	70545-0036	70545-0071	70545-0141	70545-0176
3	70545-0002	70545-0037	70545-0072	70545-0142	70545-0177
4	70545-0003	70545-0038	70545-0073	70545-0143	70545-0178
5	70545-0004	70545-0039	70545-0074	70545-0144	70545-0179
6	70545-0005	70545-0040	70545-0075	70545-0145	70545-0180
7	70545-0006	70545-0041	70545-0076	70545-0146	70545-0181
8	70545-0007	70545-0042	70545-0077	70545-0147	70545-0182
9	70545-0008	70545-0043	70545-0078	70545-0148	70545-0183
10	70545-0009	70545-0044	70545-0079	70545-0149	70545-0184
11	70545-0010	70545-0045	70545-0080		
12	70545-0011	70545-0046	70545-0081		
13	70545-0012	70545-0047	70545-0082		
14	70545-0013	70545-0048	70545-0083		
15	70545-0014	70545-0049	70545-0084		
16	70545-0015	70545-0050	70545-0085		
17	70545-0016	70545-0051	70545-0086		
18	70545-0017	70545-0052	70545-0087		
19	70545-0018	70545-0053	70545-0088		
20	70545-0019	70545-0054	70545-0089		
21	70545-0020	70545-0055	70545-0090		
22	70545-0021	70545-0056	70545-0091		
23	70545-0022	70545-0057	70545-0092		
24	70545-0023	70545-0058	70545-0093		
25	70545-0024	70545-0059	70545-0094		

SEE SHEET 1 EC NO: UCP2017-1091 DRWNG:SMIEC 2016/11/11 CHKD: APPR:FSMITH 2016/12/29 DESCRIPTION REV	QUALITY SYMBOLS	GENERAL TOLERANCES (UNLESS SPECIFIED)	DIMENSION STYLE MM/IN		SCALE	DESIGN UNITS INCH	THIRD ANGLE PROJECTION
	▽=0	4 PLACES ± --- ± ---	mm	INCH	DRAWN BY AAB	DATE 05/12/93	TITLE SALES ASSY, SL VERTICAL HEADER W/LATCH&TRI-PEGS (2.54)/.100 CENTERS molex
	▽=0	3 PLACES ± --- ± .005			CHECKED BY MJM	DATE 05/12/93	
	▽=0	2 PLACES ± 0.13 ± .01			APPROVED BY SMILLER	DATE 2013/07/22	DOCUMENT NO. SDA-70545-****
	1 PLACE ± 0.25 ± ---	ANGULAR ±1/2°	SEE TABLE		SHEET NO. 3 OF 4		
	0 PLACE ± --- ± ---	DRAFT WHERE APPLICABLE MUST REMAIN WITHIN DIMENSIONS	THIS DRAWING CONTAINS INFORMATION THAT IS PROPRIETARY TO MOLEX INCORPORATED AND SHOULD NOT BE USED WITHOUT WRITTEN PERMISSION				

CIRCUIT SIZE	ASSEMBLY ITEM NUMBER 70545		D REF.	E ± .010	MATING AREA FINISH	PC TAIL AREA FINISH
2-19	-3001-3018	WEBBED ASSEMBLY	(3.30) .130	(6.10) .240	30 GOLD	TIN
20-25	-3019-3024	WEBBED ASSEMBLY	(3.30) .130	(6.10) .240	30 GOLD	TIN
2-19	-3051-3068	WEBBED ASSEMBLY	(3.30) .130	(6.10) .240	15 GOLD	TIN
20-25	-3069-3074	WEBBED ASSEMBLY	(3.30) .130	(6.10) .240	15 GOLD	TIN
2-19	-3101-3118	WEBBED ASSEMBLY	(3.30) .130	(6.10) .240	TIN	TIN
20-25	-3119-3124	WEBBED ASSEMBLY	(3.30) .130	(6.10) .240	TIN	TIN

CIRCUIT SIZE	WEBBED ASSEMBLY ITEM NUMBER	WEBBED ASSEMBLY ITEM NUMBER	WEBBED ASSEMBLY ITEM NUMBER
2			
3			
4			
5			
6			
7			
8			
9			
10			
11			
12			
13			
14			
15			
16			
17			
18			
19			
20	70545-3019	70545-3069	70545-3119
21	70545-3020	70545-3070	70545-3120
22	70545-3021	70545-3071	70545-3121
23	70545-3022	70545-3072	70545-3122
24	70545-3023	70545-3073	70545-3123
25	70545-3024	70545-3074	70545-3124

SEE SHEET 1 EC NO: UCP2017-1091 DRINKSMIEC 2016/11/11 CHKD: APPR:FSM/TH 2016/12/29 M	DESCRIPTION QUALITY SYMBOLS □=0 □=0 □=0	GENERAL TOLERANCES (UNLESS SPECIFIED)		DIMENSION STYLE MM/IN		SCALE	DESIGN UNITS INCH	THIRD ANGLE PROJECTION		
				DRAWN BY AAB	DATE 05/12/93	TITLE SALES ASSY, SL VERTICAL HEADER W/LATCH&TRI-PEGS (2.54)X.100 CENTERS molex				
				CHECKED BY MJM	DATE 05/12/93					
				APPROVED BY SMILLER		DATE 2013/07/22	MATERIAL NO. SEE TABLE		DOCUMENT NO. SDA-70545-****	SHEET NO. 4 OF 4
DRAFT WHERE APPLICABLE MUST REMAIN WITHIN DIMENSIONS										

OPTIONAL HOUSING

WEBBED KEYING FEATURES

20 CKT HEADER
SHOWN FOR REFERENCE

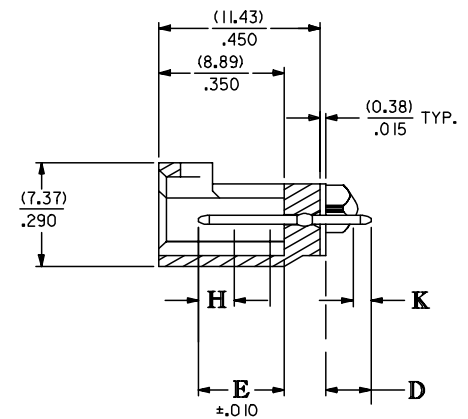
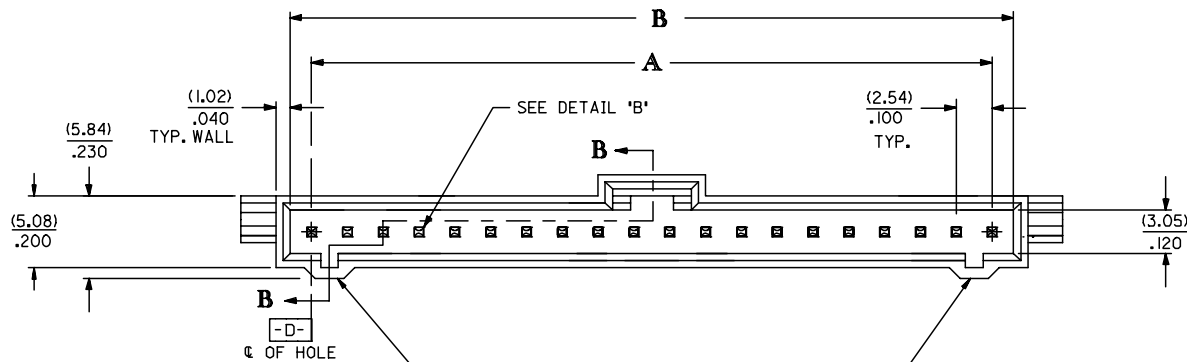
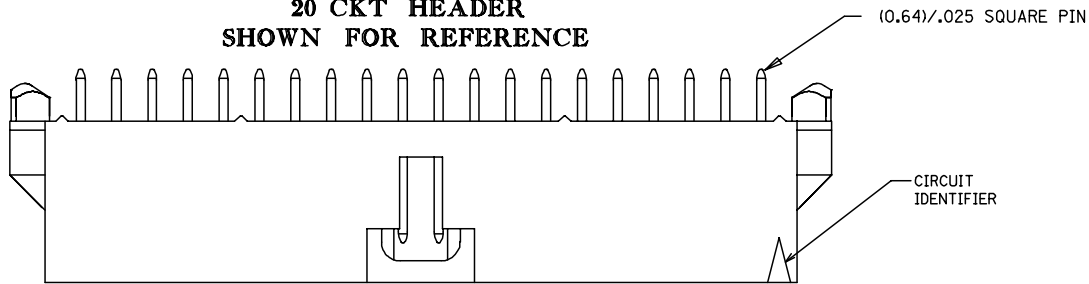



WEBBED KEYING FEATURES

SECTION B-B

UPDATE TITLE BLOCK EC NO: UCP2006-0202 DRAWN: JLOWE 2005/08/05 CHKD: ADERR 2005/08/05 APPR: FSMITH 2005/08/09	QUALITY SYMBOLS ▽=0 ▽=0	GENERAL TOLERANCES (UNLESS SPECIFIED)		DIMENSION STYLE MM/IN	SCALE ---	DESIGN UNITS INCH	THIRD ANGLE PROJECTION	
		4 PLACES ± --- ± --- 3 PLACES ± --- ± .005 2 PLACES ± 0.13 ± .01 1 PLACE ± 0.25 ± --- ANGULAR ± 1/2°	DRAWN BY WGM	DATE 07/10/96	TITLE SALES ASSY, SL VERTICAL HEADER W/LATCH&TRI-PEGS (2.54)/.100 CENTERS			
		DRAFT WHERE APPLICABLE MUST REMAIN WITHIN DIMENSIONS	CHECKED BY WGM	DATE 07/10/96	MOLEX INCORPORATED			
		SEE CHART	APPROVED BY WAZ	DATE 07/10/96	MATERIAL NO. SEE CHART	DOCUMENT NO. SDA-70545-****	SHEET NO. 2 OF 4	

	13	12	11	10	9	8	7	6	5	4	3	2	1
J	CIRCUIT SIZE	ASSEMBLY ITEM NUMBER 70545	MANUFACTURE RELEASE STATUS	WEBBED ASSEMBLY		D REF.	E ± .010	CONNECTOR END PLATING			P.C. BOARD END PLATING		
								TYPE	H MEAS.		TYPE	K MEAS.	
	2-19	-3001-3018	NOT TOOLED	WEBBED ASSEMBLY		(3.30) .130	(6.10) .240	30 GOLD	(2.54) .100		TIN	(1.27) .050	
	20-25	-3019-3024	R.F.M.										
I	2-19	-3051-3068	NOT TOOLED	WEBBED ASSEMBLY		(3.30) .130	(6.10) .240	15 GOLD	(2.54) .100		TIN	(1.27) .050	
		20-25	-3069-3074										
H	2-19	-3101-3118	NOT TOOLED	WEBBED ASSEMBLY		(3.30) .130	(6.10) .240	TIN	(2.54) .100		TIN	(1.27) .050	
		20-25	-3119-3124										
G													

CIRCUIT SIZE	WEBBED ASSEMBLY ITEM NUMBER	WEBBED ASSEMBLY ITEM NUMBER	WEBBED ASSEMBLY ITEM NUMBER
2			
3			
4			
5			
6			
7			
8			
9			
10			
11			
12			
13			
14			
15			
16			
17			
18			
19			
20	70545-3019	70545-3069	70545-3119
21	70545-3020	70545-3070	70545-3120
22	70545-3021	70545-3071	70545-3121
23	70545-3022	70545-3072	70545-3122
24	70545-3023	70545-3073	70545-3123
25	70545-3024	70545-3074	70545-3124

UPDATE TITLE BLOCK EC NO: UCP2006-0202 DRAWN: JLONE 2005/08/05 CHK'D: ADERR 2005/08/05 APPR: FSM TH 2005/08/09 REV: G1	QUALITY SYMBOLS  = 0  = 0	GENERAL TOLERANCES (UNLESS SPECIFIED)		DIMENSION STYLE IN/MM		SCALE ---	DESIGN UNITS INCH	 THIRD ANGLE PROJECTION		
		4 PLACES ± --- ± --- 3 PLACES ± --- ± .005 2 PLACES ± 0.13 ± .01 1 PLACE ± 0.25 ± --- ANGULAR ± 1/2°	mm INCH ± --- ± --- ± .005 ± .01 ± ---	DRAWN BY WGM	DATE 06/06/97	CHECKED BY WGM	DATE 06/06/97	TITLE SALES ASSY, SL VERTICAL HEADER W/LATCH&TRI-PEG (2.54)/.100 CENTER		
		DRAFT WHERE APPLICABLE MUST REMAIN WITHIN DIMENSIONS		APPROVED BY DJB	DATE 06/06/97	MATERIAL NO. SEE CHART		DOCUMENT NO. SDA-70545-****		SHEET NO. 4 OF 4
		THIS DRAWING CONTAINS INFORMATION THAT IS PROPRIETARY TO MOLEX INCORPORATED AND SHOULD NOT BE USED WITHOUT WRITTEN PERMISSION								