

### Features

- Support XTAL or Clock input at 24MHz
- Four buffered outputs support  $V_{DDO}$  operation
- Very low phase jitter(RMS) : < 1.5ps (max)
- Very low additive jitter: <300fs (typ)
- 3.3V supply voltage for Core
- 1.8V ~ 3.3V supply voltage for two output banks
- Packaging: 16-pin TSSOP
- Commercial & Industrial Temperature support

### Applications

- Networking Systems
- Femtocell BTS
- Peripheral

### Description

The PI6C490094 is a low jitter clock buffer supporting either XTAL or reference input. Two of its outputs can support wide operating voltage from 1.8V to 3.3V. It is a cost effective way to generate multiple outputs for all kinds of applications that need 24MHz with different power supplies.

### Block Diagram

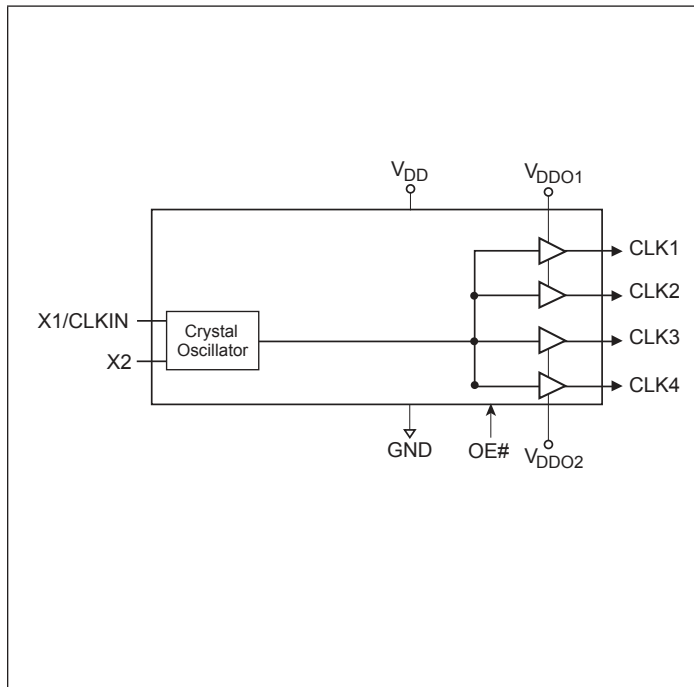

### Pin Configuration (16-Pin TSSOP)

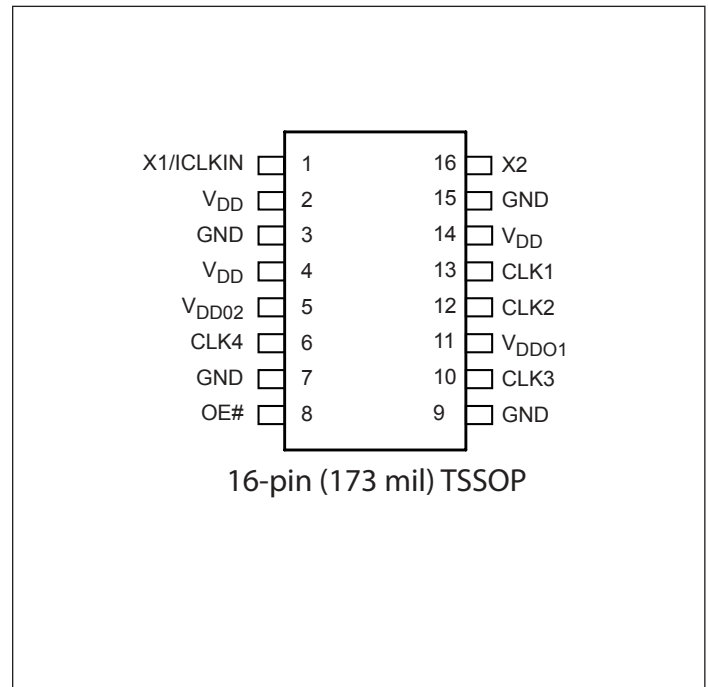

Pin number	Pin Name	Type	Description
1	X1/CLKIN	Input	Crystal connection or clock input
2, 4, 14	V <sub>DD</sub>	Power	Supply voltage 3.3V
5	V <sub>DDO2</sub>	Power	Supply voltage from 1.8V to 3.3V for CLK3 and CLK4
6	CLK4	Output	Clock Output 4
7, 9, 15	GND	Power	Connect to Ground
8	OE#	Input	Global output enable when low. Internal pull-down resistor.
10	CLK3	Output	Clock Output 3
11	V <sub>DDO1</sub>	Power	Supply voltage from 1.8V to 3.3V for CLK1 and CLK2
12	CLK2	Output	Clock Output 2
13	CLK1	Output	Clock Output 1
16	X2	Output	Crystal connection

### Function Table

OE#	CLK1/CLK2/CLK3/CLK4
0	Enabled
1	Hi-Z, weak pull down

### Maximum Ratings

(Above which useful life may be impaired. For user guidelines, not tested.)

Storage Temperature.....	-65°C to +150°C
Ambient Temperature with Power Applied .....	-40°C to +85°C
Supply Voltage to Ground Potential, V <sub>DD</sub> .....	-0.5V to +4.6V
ESD Protection (HBM) .....	2000V

**Note:** Stresses greater than those listed under MAXIMUM RATINGS may cause permanent damage to the device. This is a stress rating only and functional operation of the device at these or any other conditions above those indicated in the operational sections of this specification is not implied. Exposure to absolute maximum rating conditions for extended periods may affect reliability.

### Power Requirements (Over operating free-air temperature range)

Symbol	Parameter	Min.	Typ.	Max.	Units
V <sub>DD</sub>	Power Supply Voltage	3.135	3.3	3.465	V
V <sub>DDO</sub>	Power Supply Voltage for outputs	1.71		3.465	V
I <sub>DD</sub>	Power supply current, no load			5	mA
T <sub>A</sub>	Ambient Operating Temperature	0		+70	°C
		-40		+85	
t <sub>UP</sub>	Power Supply Ramp Time			4	ms

### DC Electrical Characteristics

Symbol	Parameter	Condition	Min.	Typ.	Max.	Units
V <sub>IH</sub>	Input High Voltage	CLKIN, OE#	V <sub>DD</sub> /2+1			V
V <sub>IL</sub>	Input Low Voltage	CLKIN, OE#			V <sub>DD</sub> /2-1	V
V <sub>OH</sub>	Output High Voltage	I <sub>OH</sub> = -8mA	V <sub>DDO</sub> - 0.4			V
V <sub>OL</sub>	Output Low Voltage	I <sub>OL</sub> = 8mA			0.4	V
Z <sub>O</sub>	Nominal Output Impedance			20		Ω
R <sub>PD</sub>	Internal Pull-down Resistor	OE#		170		kΩ
		CLKIN		220		
C <sub>IN</sub>	Input Capacitance	OE#		4		pF
		CLKIN		7.5		

**AC Electrical Characteristics** (Note 4)

Symbol	Parameter	Conditions	Min.	Typ.	Max.	Units
F <sub>IN</sub>	Input Frequency	Fundamental Crystal		24		MHz
		Input Clock		24		MHz
t <sub>R</sub>	Output Rise Time	20% to 80% 24MHz, Note 1		1		ns
t <sub>F</sub>	Output Fall Time	80% to 20% 24MHz, Note 1		1		ns
t <sub>DC</sub>	Duty Cycle		47		53	%
J <sub>phase</sub>	Clock Phase Jitter (RMS)	24MHz, Note 2			1.5	ps
J <sub>add</sub>	Additive Jitter	24MHz, Note 3		300		fs

- Note 1: Measured with 7 pF lump load.
- Note 2: 12 kHz to 20 MHz offset frequency using a crystal input.
- Note 3: CLKIN input with X2 floating.
- Note 4: Do not drive this device without a crystal or valid clock input

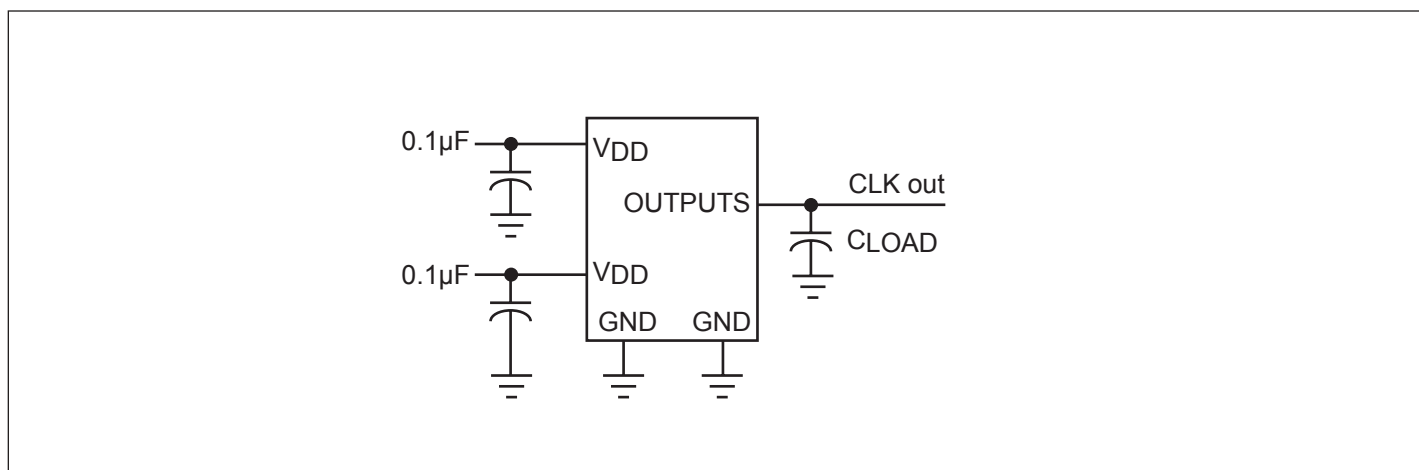

**CMOS Test Configuration**

### Crystal Oscillator Circuit

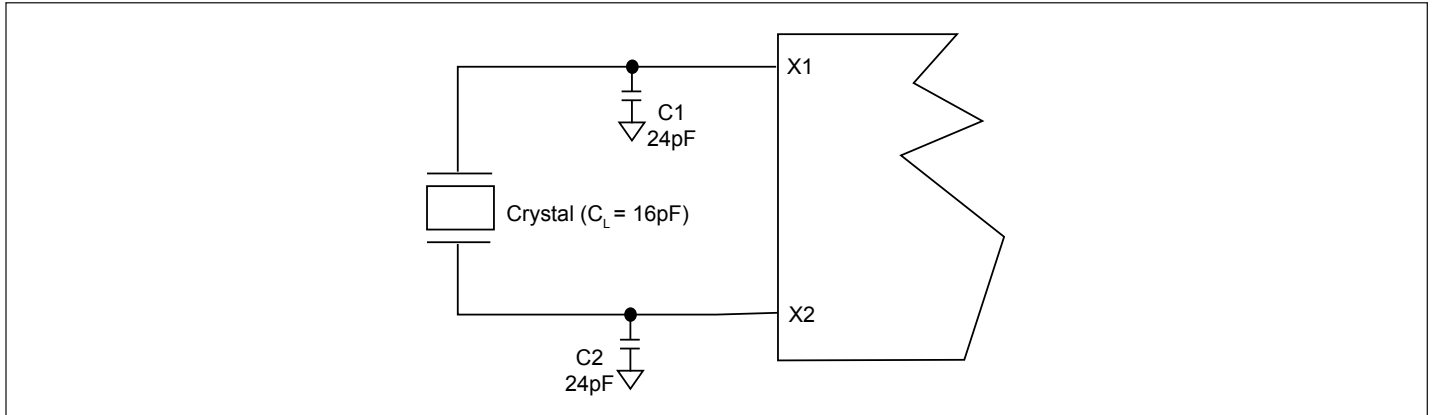

### Typical Crystal Requirement

Parameter	Minimum	Typical	Maximum	Units
Mode of Oscillation	Fundamental			
Frequency		24		MHz
Equivalent Series Resistance (ESR)			50	$\Omega$
Shunt Capacitance			7	pF
Drive Level			1	mW

### Recommended Crystal Specification

Pericom recommends:

- a) FL2400068, SMD 3.2x2.5(4P), 24MHz, CL=18pF, -20~70C, +/-20ppm, <http://www.pericom.com/pdf/datasheets/se/FL.pdf>
- b) FL2400075, SMD 3.2x2.5(4P), 24MHz, CL=18pF, -40~85C, +/-20ppm, <http://www.pericom.com/pdf/datasheets/se/FL.pdf>
- b) FY2400041, SMD 5x3.2(4P), 24MHz, CL=18pF, -20~70C, +/-30ppm, [http://www.pericom.com/pdf/datasheets/se/FY\\_F9.pdf](http://www.pericom.com/pdf/datasheets/se/FY_F9.pdf)

For other crystal options, please contact Pericom sales.

### Thermal Information

Symbol	Description	Condition	
$\Theta_{JA}$	Junction-to-ambient thermal resistance	Still air	84.0 °C/W
$\Theta_{JC}$	Junction-to-case thermal resistance		17.0 °C/W

**Packaging Mechanical: 16-Pin TSSOP (L)**

**VARIATIONS (ALL DIMENSIONS SHOWN IN MM)**

SYMBOLS	MIN.	NOM.	MAX.
A	—	—	1.20
A1	0.05	—	0.15
A2	0.80	—	1.05
b	0.19	—	0.30
c	0.09	—	0.20
D	4.90	5.00	5.10
E1	4.30	4.40	4.50
E	6.40 BSC		
[e]	0.65 BSC		
L1	1.00 REF		
L	0.45	0.60	0.75
S	0.20	—	—
$\theta$	0°	—	8°

**Notes:**  
 1. Refer JEDEC MO-153F/AB  
 2. Controlling dimensions in millimeters  
 3. Package outline exclusive of mold flash and metal burr

		DATE: 05/03/12
DESCRIPTION: 16-Pin, 173mil Wide TSSOP		
PACKAGE CODE: L		
DOCUMENT CONTROL #: PD-1310	REVISION: F	

12-0372

**Ordering Information**

Ordering Code	Package Code	Package Type	Operating Temperature
PI6C490094LE	L	Pb-free & Green, 16-pin TSSOP	Commercial
PI6C490094LIE	L	Pb-free & Green, 16-pin TSSOP	Industrial

**Notes:**

- Thermal characteristics can be found on the company web site at [www.pericom.com/packaging/](http://www.pericom.com/packaging/)
- E = Pb-free and Green
- X suffix = Tape/Reel