

NOTES: (b)

1. RECOMMENDED SOLDER INSTRUCTION SEE SHEET 2
2. METALSHELLS: COPPER ALLOY; min. 315µm TIN over 40-80µm NICKEL
3. INSULATORS: PBT GF UL 94 V-0, BLACK
4. SIGNAL CONTACTS: COPPER ALLOY; PLATING (SEE PART NO.)
 - PLEASE ADD C for 30µm HARD GOLD over min. 50µm NICKEL
 - PLEASE ADD B for 20µm HARD GOLD over min. 50µm NICKEL
 - PLEASE ADD A for GOLD FLASH over NICKEL (PREFERRED TYPE)
- SOLDER CUP ACCEPTS CABLE AWG 20
5. THREADED INSERTS: COPPER ALLOY; min. 200µm TIN over 80µm NICKEL
6. COLLARS: COPPER ALLOY; min. 200µm TIN over 80µm NICKEL
7. FRAME: ZINC DIE CAST; NICKEL PLATED
8. RUBBER-GASKET: TPE; BLACK
9. HEXLOCKING SCREW: STAINLESS STEEL
10. O-RING: SILICON; BLUE
11. SEALING COMPOUND: PUR; BLUE
12. RECOMMENDED PANEL CUT-OUT SEE SHEET 2
13. RECOMMENDED TORQUE FOR MOUNTING SCREW 35Ncm (3.1 in.LB) / max.40Ncm (3.5 in.LB)
14. CONNECTOR IS PART MARKED: 6STD09P□M99B30X CONEC ABC (see note 4)

AT ALL TIMES WATER RESISTANT CONNECTORS NOT IN USE SHOULD BE COVERED WITH A CONEC WATER RESISTANT CAP OR WATER TIGHT HOOD.

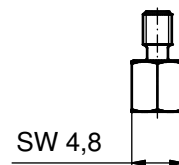
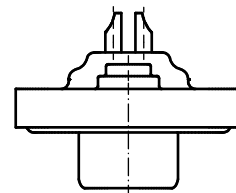
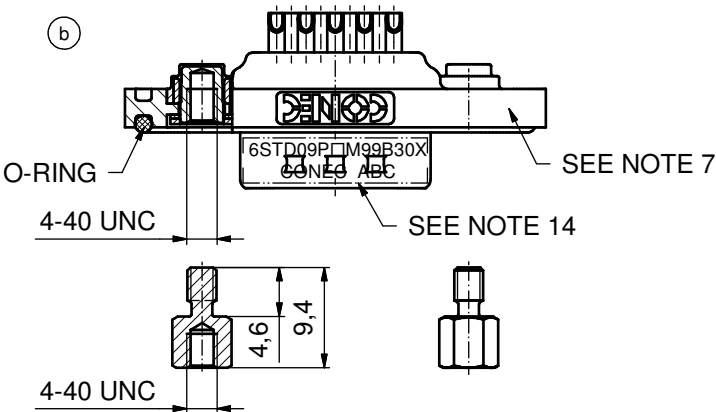
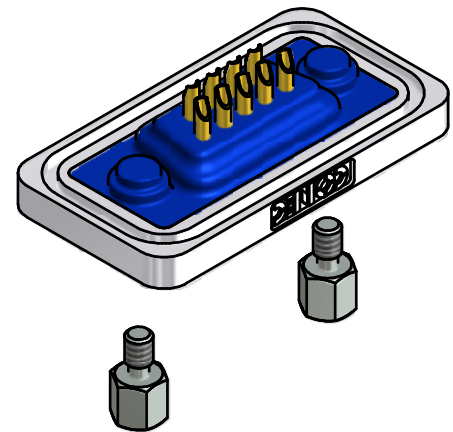
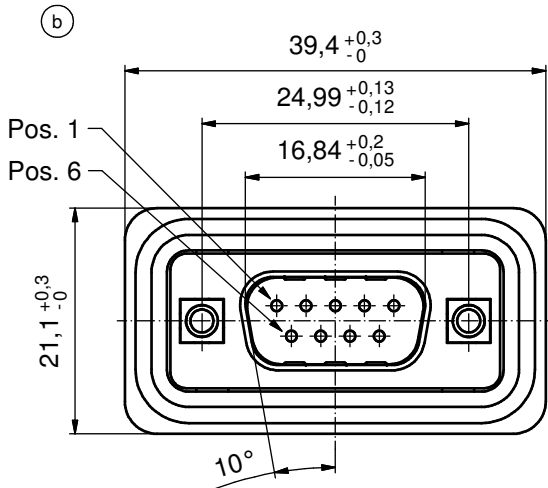
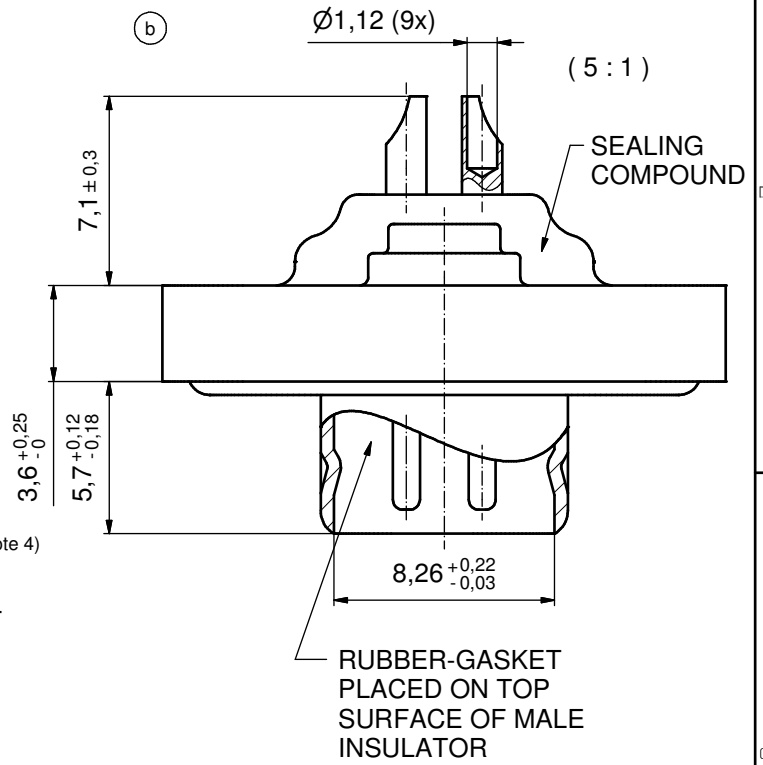

Directive 2002/95/EC RoHS compliant

THIS DRAWING MAY NOT BE COPIED OR REPRODUCED IN ANY WAY, AND MAY NOT BE PASSED ON TO A THIRD PARTY WITHOUT WRITTEN PERMISSION. OWNERSHIP AND COPYRIGHT OF CONEC GmbH DO NOT ALTER CAD DRAWING BY HAND	tolerance		dim. in mm		scale:	2:1 (5:1)
	date		name		material:	SEE NOTES
	drawn	02.08.12	Henneboel		title:	
	appd.	02.08.12	Fischer			
	norm					
d-old	15K1A695/18K1A372/18K2A372			dwg no:		DIN-A3
5 x b	A4410	02.08.2012	K.H.	15K1A1109 (b)		sh: 1/2
a	Original			part no: 6STD09P□M99B30X (see note 4)		
rev.	description	date	name	CONEC		

Solder Instruction

1. Cable should be prepared for soldering. The cable/wires must be pretinned.
2. Insert cable/wire into solder cup.
3. Operate the soldering iron at 350 °C, 50 Watt max. and use a pencil tip.
4. Put tip to wire in solder cup.
5. After 1 second bring in solder.
6. Heat for 3 seconds longer. Do not heat contact more than 4 seconds in total.
7. Remove soldering iron.
8. Wait until solder gets rigid again.
9. Do not solder adjacent contacts consecutively,
alternate position within the connector to minimize heat build up.

RECOMMENDED PANEL CUT-OUT

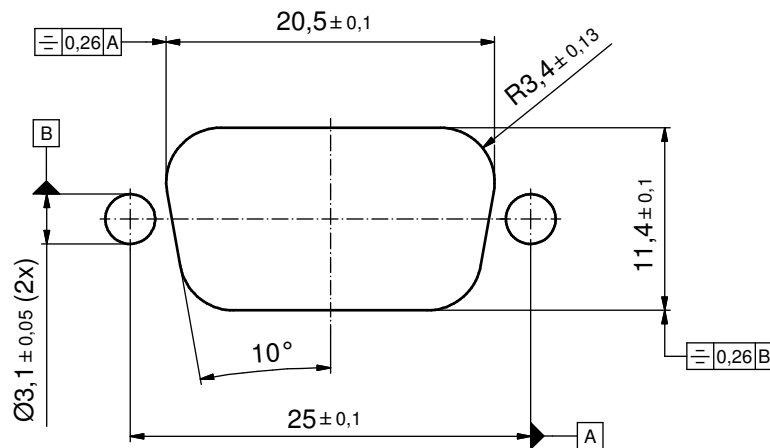

THIS DRAWING MAY NOT BE COPIED OR REPRODUCED IN ANY WAY, AND MAY NOT BE PASSED ON TO A THIRD PARTY WITHOUT WRITTEN PERMISSION. OWNERSHIP AND COPYRIGHT OF CONEC GmbH DO NOT ALTER CAD DRAWING BY HAND				tolerance		scale: 3:1
				date	name	material: SEE SHEET 1
				drawn	02.08.12	Henneboel
				appd.	02.08.12	Fischer
				norm		
				d-old		
				rev.		
a	Original		CONEC [®]			title: PANEL CUT-OUT D-SUB MALE 9pos. SOLDER CUP with threaded insert and hexlocking screw
rev.	description	date				name
						part no: SEE SHEET 1