

ITEM	QTY	PART NUMBER	PART DESCRIPTION
1	1	DC-XXX-XXX	DEEP CHANNEL PRESS-IN CARD GUIDE
2	1	CS-600 F-10.75	CONDUCTIVE INSERT

REV.	DESCRIPTION	DATE	APPROVED
A	Engineering Release	02/06/03	M. C.
B	ECO#388, Engineering Update.	05/01/03	M. C.
C	Updated Conductive Insert P/N	03/12/08	M. C.
D	12 Additional Lengths Added	07/25/13	T. Y.
E	Engineering Update w/o Changes	05/13/16	J. C.

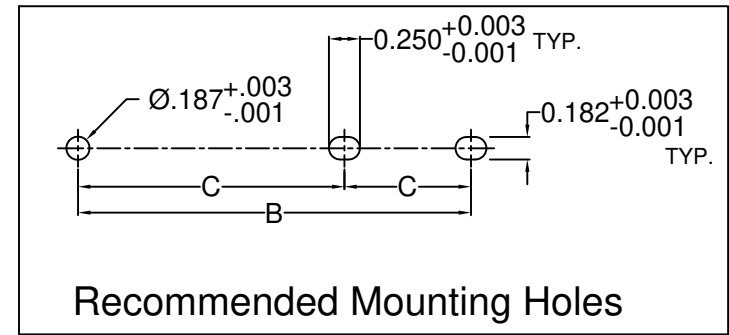
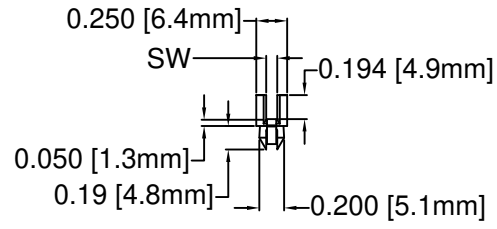
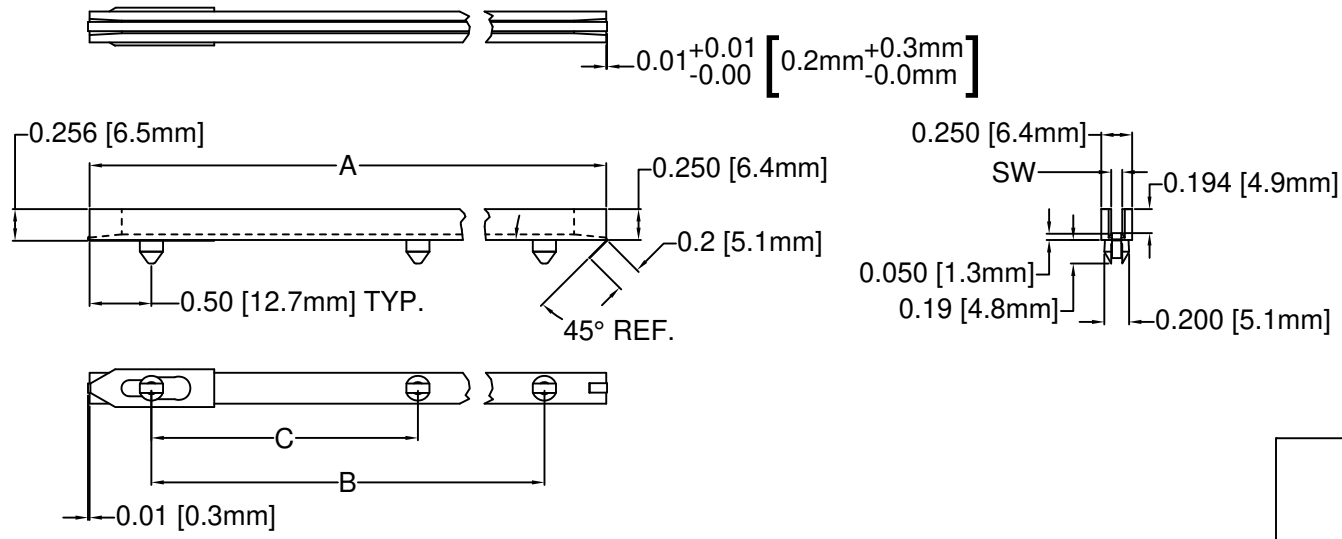

PART NO.	A ±.062 (1.6)	B ±.032 (.8)	C ±.015 (.4)	S.W. ±.005 (.1)	PCB THICK- NESS	DESC DWG. NO.
DC-250 CI	2.5 (63.5)	1.5 (38.1)	--			84101-01
DC-400 CI	4.0 (101.6)	3.0 (76.2)	--			--
DC-450 CI	4.5 (114.3)	3.5 (88.9)	--			84101-02
DC-500 CI	5.0 (127.0)	4.0 (101.6)	--			--
DC-550 CI	5.5 (139.7)	4.5 (114.3)	--	.080 (2.0)	1/16 (1.6)	--
DC-600 CI	6.0 (152.4)	5.0 (127.0)	--			84101-03
DC-650 CI	6.5 (165.1)	5.5 (139.7)	--			--
DC-700 CI	7.0 (177.8)	6.0 (152.4)	--			--
DC-750 CI	7.5 (190.5)	6.5 (165.1)	--			--
DC-800 CI	8.0 (203.2)	7.0 (177.8)	3.5 (88.9)			84101-04
DC-400-102 CI	4.0 (101.6)	3.0 (76.2)	--			--
DC-450-102 CI	4.5 (114.3)	3.5 (88.9)	--			--
DC-500-102 CI	5.0 (127.0)	4.0 (101.6)	--	.102 (2.6)	3/32 (2.4)	--
DC-550-102 CI	5.5 (139.7)	4.5 (114.3)	--			--
DC-600-102 CI	6.0 (152.4)	5.0 (127.0)	--			--
DC-650-102 CI	6.5 (165.1)	5.5 (139.7)	--			--
DC-700-102 CI	7.0 (177.8)	6.0 (152.4)	--			--
DC-750-102 CI	7.5 (190.5)	6.5 (165.1)	--			--
DC-800-102 CI	8.0 (203.2)	7.0 (177.8)	3.5 (88.9)			--
DC-450-130 CI	4.5 (114.3)	3.5 (88.9)	--			84101-22
DC-600-130 CI	6.0 (152.4)	5.0 (127.0)	--	.132 (3.4)	1/8 (3.2)	84101-23
DC-800-130 CI	8.0 (203.2)	7.0 (177.8)	3.5 (88.9)			84101-24

STANDARD TOLERANCE (UNLESS OTHERWISE SPECIFIED)		 BIVAR [®] 4 THOMAS, IRVINE, CA. 92618 TEL: (949) 951-8808 FAX: (949) 951-3974	
DECIMALS	ANGULAR		
.X ±.1	X° ± 1°		TITLE: DEEP CHANNEL CARD GUIDE
.XX ±.01			
.XXX ±.005			
DESIGNED: D. Green	DATE: 01/06/03	PART NO: DC-XXX-XXX-CI	
CHECKED: M. Chen	DATE: 01/06/03	REVISION: E	
		CAGE CODE : 32559 SHEET # 1 OF 1	
CAD GENERATED DOCUMENT. DO NOT MEASURE DRAWING.			