

REVISIONS				
P	LTR	DESCRIPTION	DATE	APPV
M		REV PER ECO-15-015252	13NOV15	BJ FY

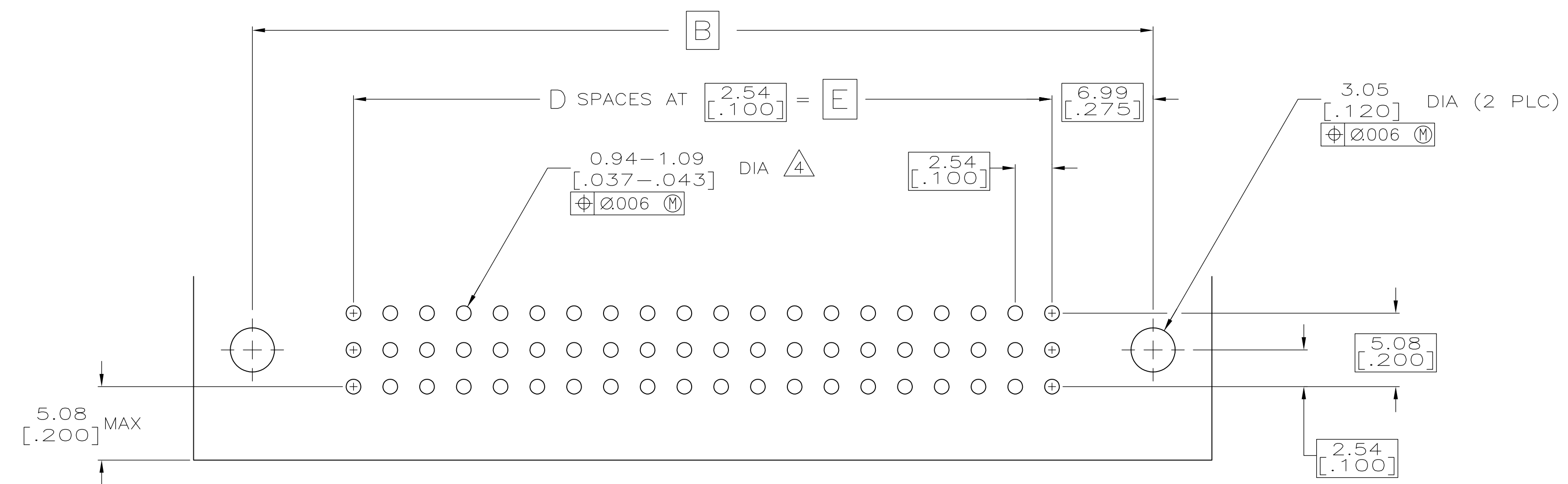
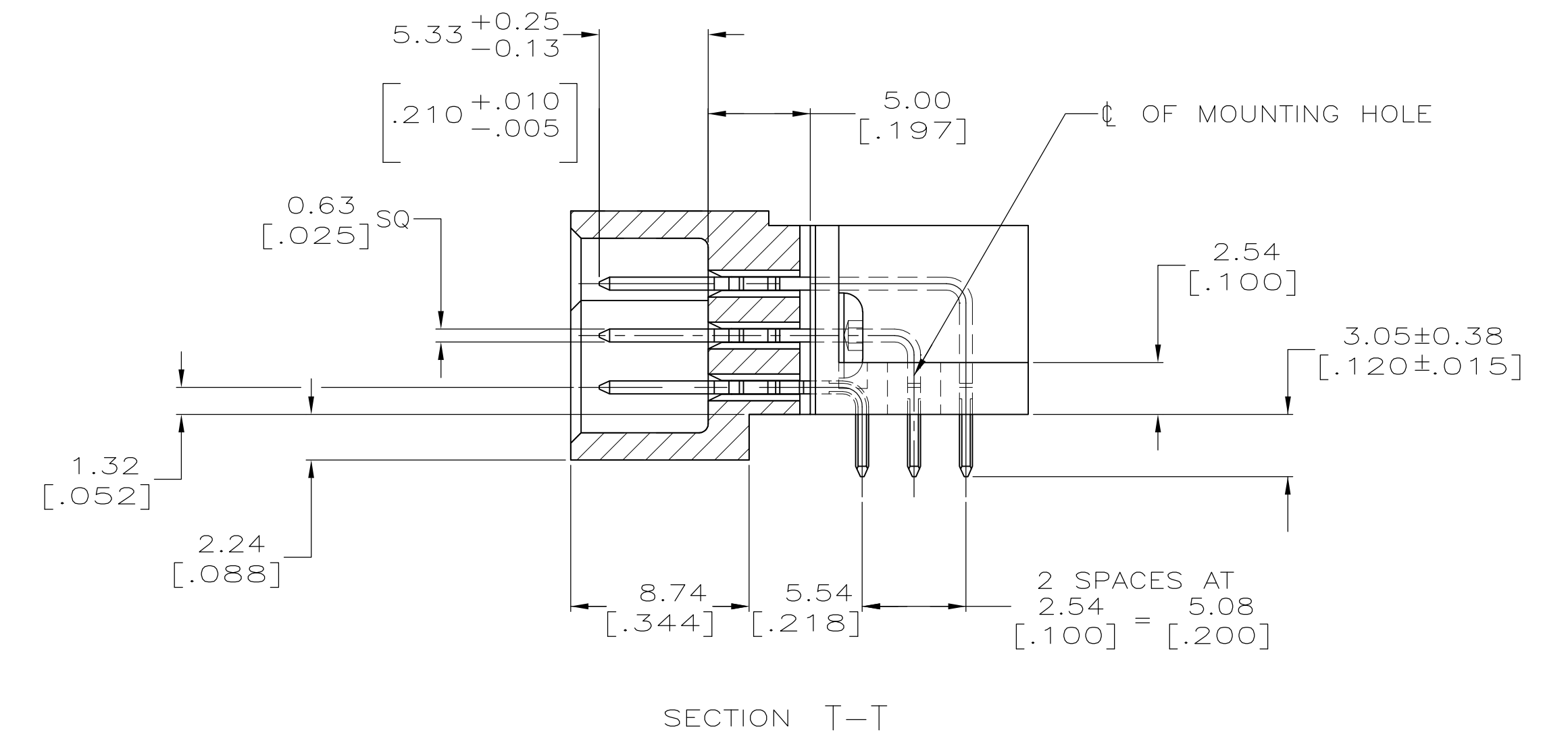
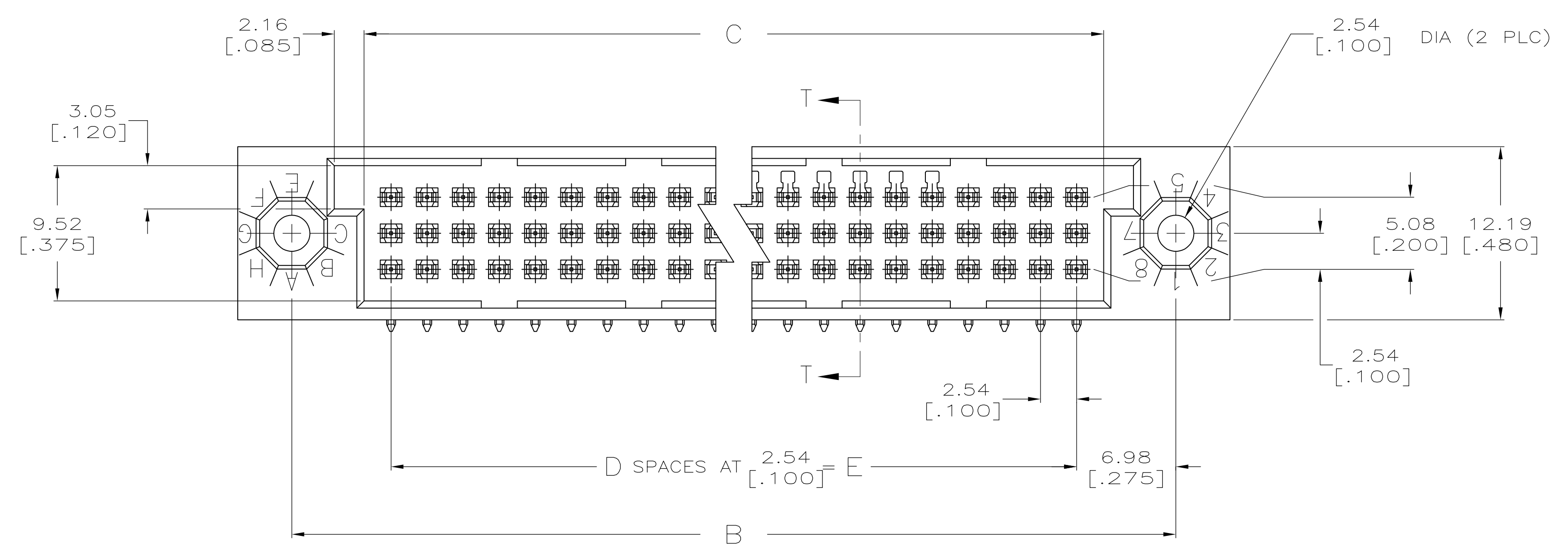
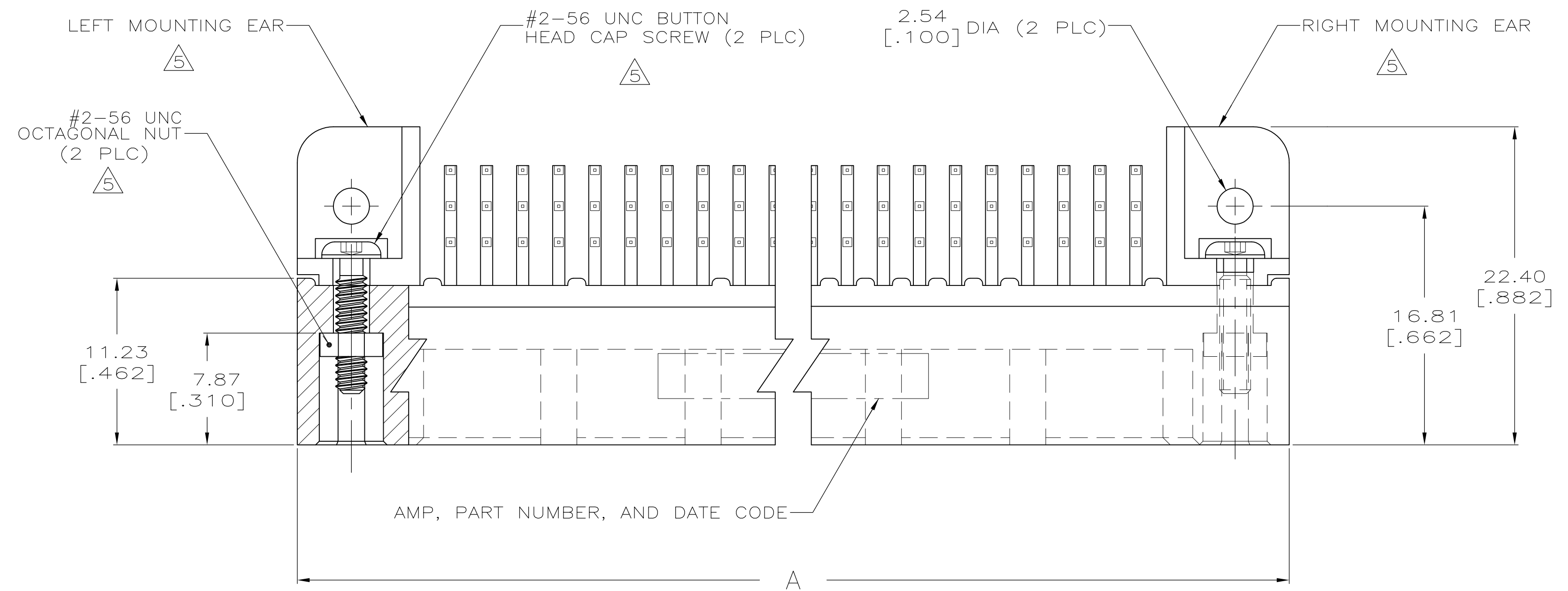

RECOMMENDED P.C. BOARD LAYOUT

THIS DRAWING IS A CONTROLLED DOCUMENT.		DIN R.K. SEIFRIED 05/17/90	TE Connectivity	
DIMENSIONS: mm [INCHES]		CHK J.D.WEARY 02/11/92		
TOLERANCES UNLESS OTHERWISE SPECIFIED:		APPV J.D.WEARY 02/11/92	NAME ASSY, HDI, 3 ROW, RIGHT ANGLE PIN	
0 PLC ± -		PRODUCT SPEC	3.05 [.120] LONG SOLDER TAILS	
1 PLC ± -		APPLICATION SPEC	SIZE A1	
2 PLC ± -		WEIGHT 0	CAGE CODE 00779	
3 PLC ± 0.13 [.005]		DRAWING NO. 533288	SCALE 4:1	
4 PLC ± -		CUSTOMER DRAWING	SHEET 1 OF 2	
ANGLES ± -		REV M		

REVISIONS				
P	LTR	DESCRIPTION	DATE	APPV
-		SEE SHEET 1	-	-

- ① HOUSING MATERIAL: THERMOPLASTIC, COLOR-BLACK.
- ② CONTACT MATERIAL: PHOSPHOR BRONZE.
- ③ FINISH:
MATING AREA: MEETS THE PERFORMANCE REQUIREMENTS OF PRODUCT SPECIFICATION 108-9063; BASED ON TELCORDIA DR-1217-CORE APPLICATIONS IN UNCONTROLLED ENVIRONMENTS.
SOLDER TAILS AREA: TIN-LEAD PLATED.
- ④ RIGHT ANGLE PIN RECOMMENDED P.C. BOARD HOLE SIZES ARE 0.94-1.09 [.037-.043]; RECOMMENDED PAD DIA IS 1.52 [.060].
- ⑤ MOUNTING EARS AND HARDWARE PURCHASED SEPARATELY, KIT PART NUMBER 533050-1.
- 6. DIMENSIONS IN BRACKETS ARE IN INCHES.
- ⑦ HOUSINGS WITH CENTER MOUNTING IS RECOMMENDED FOR ASSEMBLIES HAVING 75 CONTACTS PER ROW OR MORE.
- ⑧ PART NUMBER IS OBSOLETE.

⑧	144.78 [5.700]	57	148.59 [5.850]	158.75 [6.250]	166.37 [6.550]	174	1-533288-8
⑧	251.46 [9.900]	99	255.27 [10.050]	265.43 [10.450]	273.05 [10.750]	300	1-533288-7
⑧	238.76 [9.400]	94	242.57 [9.550]	252.73 [9.950]	260.35 [10.250]	285	1-533288-6
⑧	226.06 [8.900]	89	229.87 [9.050]	240.03 [9.450]	247.65 [9.750]	270	1-533288-5
⑧	213.36 [8.400]	84	217.17 [8.550]	227.33 [8.950]	234.95 [9.250]	255	1-533288-4
⑧	200.66 [7.900]	79	204.47 [8.050]	214.63 [8.450]	222.25 [8.750]	240	1-533288-3
⑧	187.96 [7.400]	74	191.77 [7.550]	201.93 [7.950]	209.55 [8.250]	225	1-533288-2
⑧	175.26 [6.900]	69	179.07 [7.050]	189.23 [7.450]	196.85 [7.750]	210	1-533288-1
⑧	162.56 [6.400]	64	166.37 [6.550]	176.53 [6.950]	184.15 [7.250]	195	1-533288-0
⑧	149.86 [5.900]	59	153.67 [6.050]	163.83 [6.450]	171.45 [6.750]	180	533288-9
⑧	137.16 [5.400]	54	140.97 [5.550]	151.13 [5.950]	158.75 [6.250]	165	533288-8
	124.46 [4.900]	49	128.27 [5.050]	138.43 [5.450]	146.05 [5.750]	150	533288-7
⑧	111.76 [4.400]	44	115.57 [4.550]	125.73 [4.950]	133.35 [5.250]	135	533288-6
	99.06 [3.900]	39	102.87 [4.050]	113.03 [4.450]	120.65 [4.750]	120	533288-5
⑧	86.36 [3.400]	34	90.17 [3.550]	100.33 [3.950]	107.95 [4.250]	105	533288-4
⑧	78.74 [3.100]	31	82.55 [3.250]	92.71 [3.650]	100.33 [3.950]	96	533288-3
	73.66 [2.900]	29	77.47 [3.050]	87.63 [3.450]	95.25 [3.750]	90	533288-2
⑧	60.96 [2.400]	24	64.77 [2.550]	74.93 [2.950]	82.55 [3.250]	75	533288-1
	E	D	C	B	A	POSN	PART NUMBER

THIS DRAWING IS A CONTROLLED DOCUMENT.		DIN R.K. SEIFRIED 05/17/90		TE Connectivity	
DIMENSIONS: mm [INCHES]		TOLERANCES UNLESS OTHERWISE SPECIFIED:			
0 PLC ± - 1 PLC ± - 2 PLC ± - 3 PLC ± 0.13 [.005] 4 PLC ± - ANGLES ± -		CHK J.D.WEARY 02/11/92 APPV J.D.WEARY 02/11/92 PRODUCT SPEC APPLICATION SPEC		NAME ASSY, HDI, 3 ROW, RIGHT ANGLE PIN 3.05 [.120] LONG SOLDER TAILS	
MATERIAL		FINISH		SIZE CASE CODE DRAWING NO WEIGHT 0 A1 00779 533288	
① ②		③		CUSTOMER DRAWING SCALE 4:1 SHEET 2 OF 2 REV M	