

PART NUMBER	REV	FIRST USED
680150-1	D	854400-1
680150-2	D	565435-5

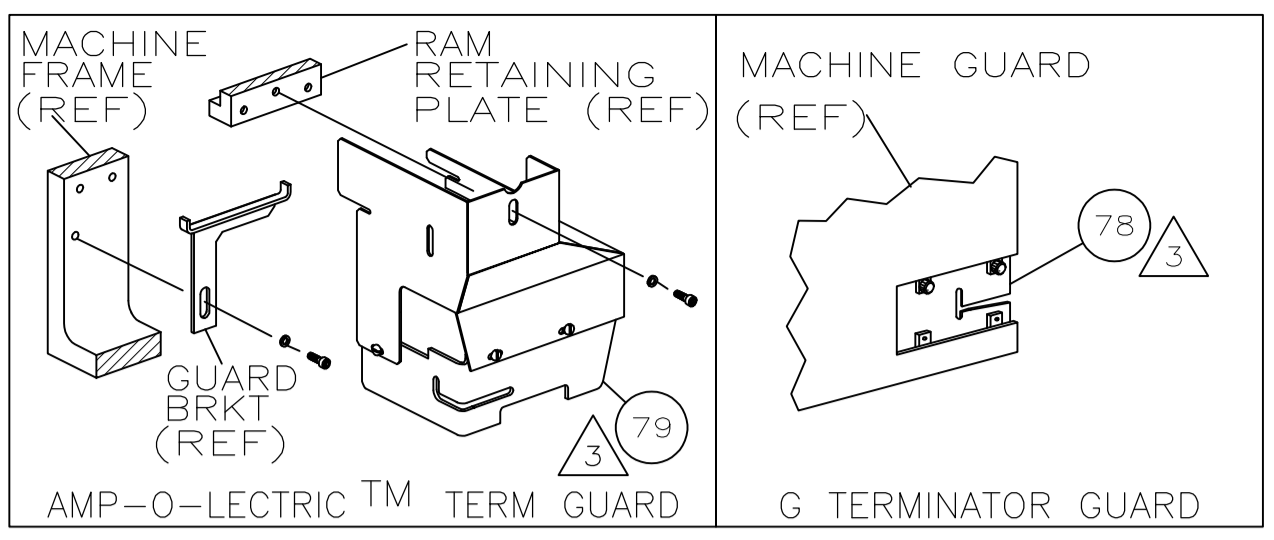

TERMINAL NAME: Ø.180 SHUR PLUG

CRIMPING DATA			
PAD LTR	CRIMP HEIGHT	WIRE SIZE	
A	.074 ±.002 [1.88 ±0.05mm]	14	
B	.065 ±.002 [1.65 ±0.05mm]	16	
C	.059 ±.002 [1.5 ±0.05mm]	18	
D	NOT	USED	
CRIMP	SIZE	TYPE	RANGE
WIRE	.110 [-2.79mm]	F	18-14
INSUL	-	-	-

WIRE STRIP LENGTH	TERM APPL SPEC	FEED	APPL INSTRUCTION	SET UP GAGE	LAYOUT
.141-.171	114-2017	.805	408-8039	458638-1	L1632

LOC	DIST	REVISIONS			
F	LTR	DESCRIPTION	DATE	DN	APVO
A	66	ECR-09-014402	6-2009	MY	GB

-1	LEADMAKER & BENCH MODEL G	MECH POST FEED
-2	BENCH MODEL K	MECH POST FEED

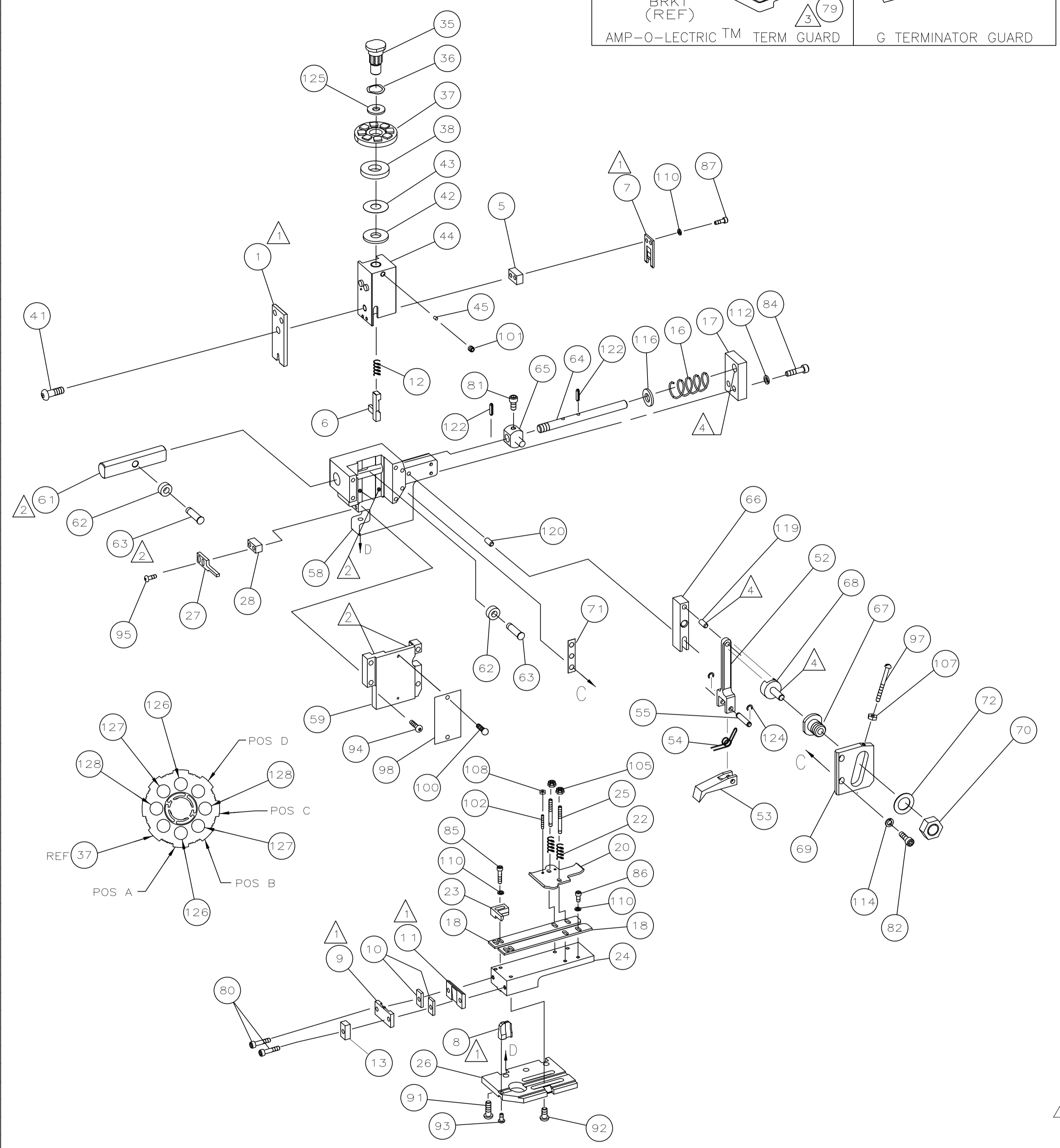

2	2	-	1-354779-7	PIN, WIRE DISC (.3075)C	129
2	2	-	354779-4	PIN, WIRE DISC (.3010)B	127
2	2	-	8-354778-4	PIN, WIRE DISC (.2915)A	126
1	1	-	986950-1	WASHER, FLAT PRECISION	125
REF	REF	-	21045-3	RING, RET "C" (Ø.187)FD PIN	124
REF	REF	-	5-21028-1	PIN, STD SPRING (Ø.12)FD ADJ ROD	122
REF	REF	-	1-21030-7	PIN, DOWEL (Ø.187x1.50)HSG	120
REF	REF	-	1-21030-1	PIN, DOWEL (Ø.187x.50)LEVER	119
REF	REF	-	21899-4	WASHER, FLAT (Ø5/16)SCR ADJ	116
REF	REF	-	21024-5	WASHER, LOCK (NO.10)FD ADJ PL	114
REF	REF	-	21024-5	WASHER, LOCK (NO.10)FD ROD GDE	112
7	7	-	21024-4	WASHER, LOCK (NO.8)SHEAR BL	110
2	2	-	21018-4	NUT, HEX (4-40)DRAG	108
REF	REF	-	21018-5	NUT, HEX (6-32)FD ADJ PL	107
2	2	-	21022-2	NUT, HEX SL (8-32)DRAG STUD	105
2	2	-	2-21006-6	SCR, SKT SET (4-40x.62)DRAG	102
1	1	-	21009-2	SCR, SKT SET (1/4-20x.25)RAM	101
2	2	-	21017-2	SCR, DRIVE (#2x.19)ID PLATE	100
1	1	-	1-21002-7	SCR, BHC (6-32x.38)CAM	99
1	1	-	461264-1	PLATE, IDENTIFICATION	98
REF	REF	-	6-23715-5	SCR, PAN HD (6-32x1.50)FEED ADJ	97
2	2	-	2-21002-2	SCR, BHC (8-32x.50)STRIPPER	95
REF	REF	-	2-21002-9	SCR, BHC (10-32x.75)HSG CAP	94
1	1	-	22733-8	SCR, BHC (8-32x.38 LW)ANVIL	93
4	4	-	3-21002-3	SCR, BHC (1/4-20x.50)ST GD PL	92
REF	REF	-	2-22733-8	SCR, BHC (1/4-20x.62)BASE PL	91
REF	REF	-	3-21000-6	SCR, SKT CAP (10-32x.38)PIVOT BL	81
REF	REF	-	3-21000-4	SCR, SKT CAP (10-32x.38)PIVOT BL	81
2	2	-	3-21002-1	SCR, BHC (10-32x1.00)SH PL	80
REF	REF	-	455745-1	GUARD, WINDOW	79
REF	REF	-	679532-1	INSERT, GUARD	78
REF	REF	-	458109-1	WASHER, FLAT (SPECIAL)	72
REF	REF	-	690517-1	SPACER	71

REF	REF	QTY	DESCRIPTION	ITEM NO	
REF	REF	-	22594-8	NUT, HEX	70
REF	REF	-	240628-1	PLATE, ADJ	69
REF	REF	-	240626-1	SHAFT, PIVOT	68
REF	REF	-	240633-1	BUSHING	67
REF	REF	-	455680-1	LEVER, INTERMEDIATE	66
REF	REF	-	240629-1	BLOCK, PIVOT	65
REF	REF	-	240632-2	SCR, ADJ	64
REF	REF	-	240659-3	PIN, CAM ROLLER	63
REF	REF	-	240658-1	CAM, ROLLER	62
REF	REF	-	454398-1	ROD, FEED	61
REF	REF	-	454220-1	CAP, RAM	59
REF	REF	-	453736-1	HOUSING	58
REF	REF	-	240624-1	PIN, FEED FINGER	55
REF	REF	-	691499-1	SPRING, FEED FINGER	54
REF	REF	-	240635-1	FINGER, FEED	53
REF	REF	-	240634-3	LEVER, TERMINAL	52
1	-	-	690501-3	CAM, POST FEED 1 1/8 ST	48
-	1	-	690501-4	CAM, POST-FEED 1 5/8 ST	47
1	1	-	690191-1	PLUG, NYLON	45
1	1	-	455674-1	RAM	44
1	1	-	690125-1	WASHER, LAMINATED	43
1	1	-	690124-1	WASHER, RAM	42
1	1	-	7-21002-9	BOLT, CRIMPER (5/16-24x1.00)	41
1	1	-	690223-2	SPACER, INSULATION DISC	38
1	1	-	354777-1	WIRE DISC, PLASTIC	37
1	1	-	22480-5	WASHER, SPRING	36
1	1	-	690212-1	POST, RAM	35
1	1	-	458980-2	APPLICATOR, BASIC (SUB ASSY)	32
1	1	-	3-690451-2	SPACER, STRIPPER	28
1	1	-	240639-1	STRIPPER	27
REF	REF	-	455676-1	PLATE, BASE	26
2	2	-	22354-8	DRAG, STUD	25
1	1	-	455678-3	PLATE, STRIP GUIDE	24
1	1	-	240825-1	PLATE, STRIP HOLD DOWN	23
2	2	-	4-22281-1	SPRING, DRAG	22
1	1	-	454177-1	DRAG, STOCK	20
2	2	-	454204-4	GUIDE, STRIP (FRONT)	18
REF	REF	-	454178-1	GUIDE, FEED ROD	17
REF	REF	-	4-22284-9	SPRING, FEED RETURN	16
1	1	-	690481-2	SPACER, HOLD DOWN	13
1	1	-	23846-1	SPRING, HOLD DOWN	12
1	1	-	240644-5	PLATE, REAR SHEAR	11
2	2	-	1-240645-7	SPACER, SHEAR PLATE	10
1	1	-	318107-1	PLATE, FRONT SHEAR	9
1	1	-	240693-6	ANVIL	8
1	1	-	1-240651-0	BLADE, SLUG	7
1	1	-	3-455892-0	HOLD DOWN, TERMINAL	6
1	1	-	6-240641-5	SPACER, SLUG BLADE	5
1	1	-	2-456408-8	CRIMPER, WIRE	1

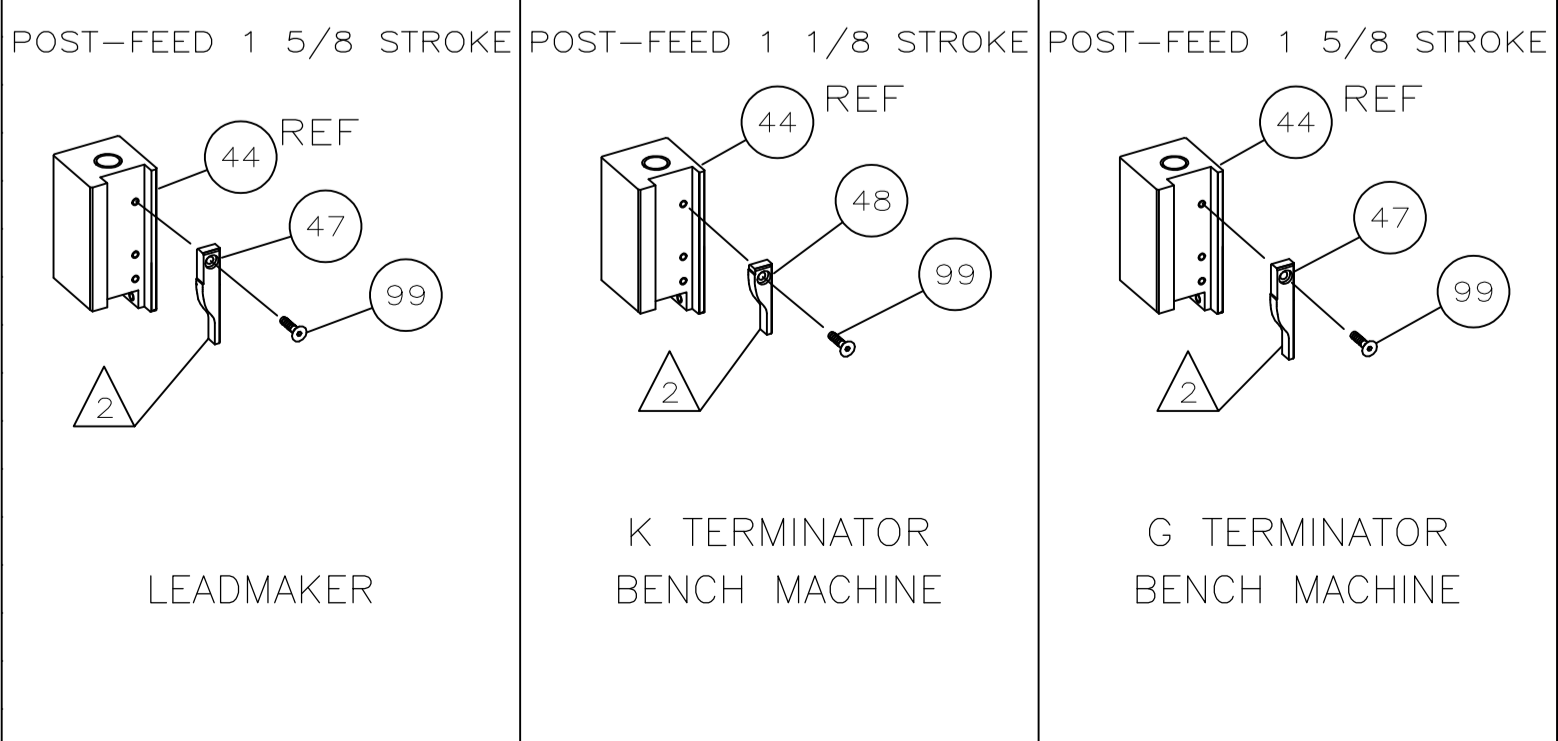

- 1 RECOMMENDED SPARE PARTS.
- 2 GREASE LIGHTLY.
- 3 GUARD MUST BE IN PLACE WHEN OPERATING APPLICATOR IN A BENCH MACHINE.
- 4 LUBRICATE DAILY USING NO. 20 MACHINE OIL.
- 5 ITEMS WITH QTY OF REF SPECIFIED (EXCEPT ITEMS 78 AND 79) ARE USED ON ITEM 32.
- 6 ITEM 78 USED WITH G TERMINATOR ONLY.

QTY REQD	PER ASSY	PART NO	DESCRIPTION	ITEM NO
-2	-1	U/M		

THIS DRAWING IS A CONTROLLED DOCUMENT.

DIN P. MATHIAS 2/23/95
 CHK: C. FERISMAN 6-20-95
 APVO: A. BEDDICK 6-20-95

Tyco Electronics Corporation
 Harrisburg, PA 17105-3608

END FEED HDM APPLICATOR

SIZE: A1
 CAGE CODE: 00779
 DRAWING NO: 680150

CUSTOMER DRAWING