



佳承精工股份有限公司

CHIA CHERNE INDUSTRY CO.,LTD.

承認書

APPROVAL SHEET

GP

品名:	COOLER	
DESCRIPTION	_____	
規格:	JACL511C	
TYPE/MODEL	(First Version Valid From 03/01/07)	
客戶:	COOLJAGUSA	
BUYER	_____	
日期:	_____	
DATE	_____	
審核	確認	經辦
APPROVER <i>Ausie</i>	CHECKER <i>Penny</i>	HANDLER <i>Zony</i>



客戶承認印				
APPROVAL SIGNATURES				
審核	確認	主辦	結論	印章
APPROVER	CHECKER	HANDLER	CONCLUSION	SIGNATURE

NO. 55, Alley 121, Lane 175, Kousheng Rd., Changhua City, Taiwan
 彰化市國聖路 175 巷 121 弄 55 號
 TEL. +886 4 732 3090 FAX. +886 4 738 3155
<http://www.cooljag.com>

JACL511C



Application	Intel Socket 775 - 1U
Specification	
Weight	~ 387g
Dimension	80L×80W×28H (mm)
Heat sink	
Model	JAH511C
Material	Copper C1100
Fin pitch	1.2 (mm)
Fin thickness	~0.45 (mm)
Rated Voltage	DC12V
Rated Current	0.80A
Rated Speed	5500RPM ±10%

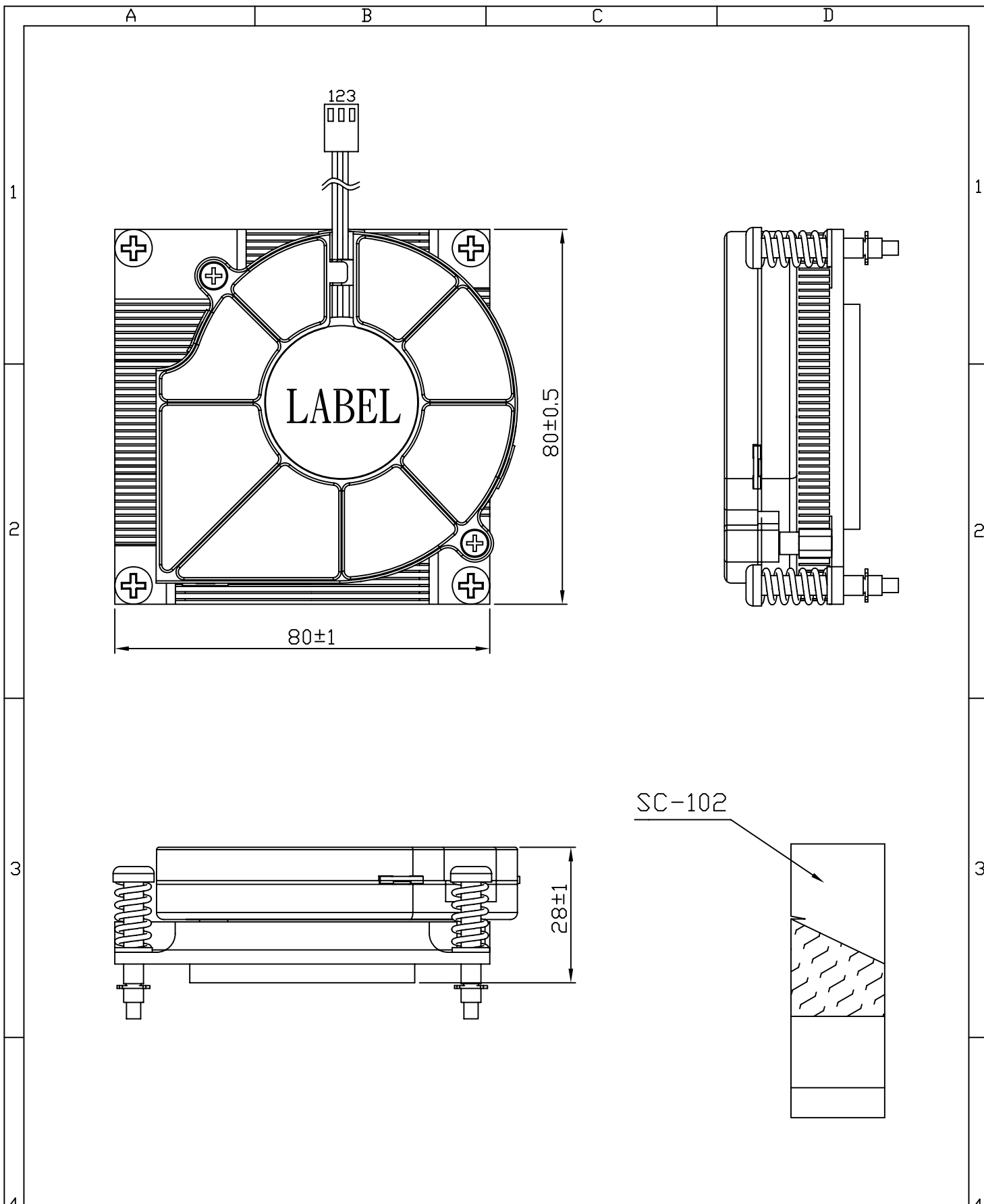

MODEL	JACL511C		NAME	COOLER						
DRN	Tony	02/28 2007	MATERIAL	--		REV.	DESCRIPTION	SIGN	DATE	
DSN	John	02/28 2007	FINISH	--			DIM IN	mm	DO NOT SCALE	DWG
CKD	Richard	02/28 2007	CHIA CHERNE INDUSTRY CO.,LTD				SHEET	1	OF	1
APPD	Auric	02/28 2007				DRAWING NO.			JACL511C	

A B C D

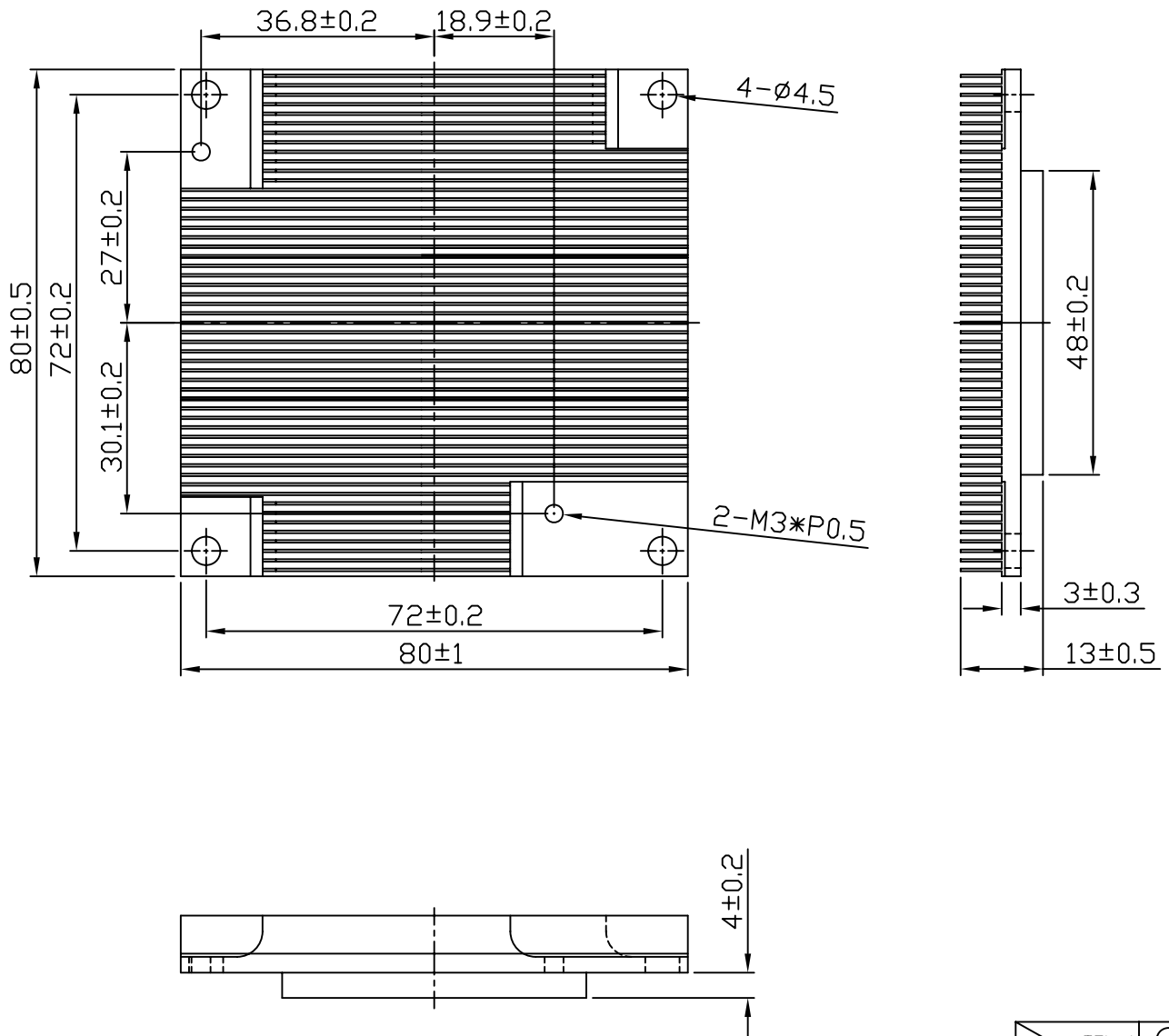

Not:1. Fin Pitch is 1.2mm °
 2. Fin Thickness is about 0.45mm °

TOL ±	URS
0~6	0.20
6~30	0.25
30~120	0.45
120~300	0.80
300~600	1.20
600~1200	1.50
ANG. TOL ±	1°

MODEL	JAH511C		NAME	HEATSINK					
DRN	Tony	02/28 2007	MATERIAL	CU1100		REV.	DESCRIPTION	SIGN/DATE	
DSN	John	02/28 2007	FINISH	Anti-oxidized			DIM IN	mm	DO NOT SCALE DWG
CKD	Richard	02/28 2007	CHIA CHERNE INDUSTRY CO.,LTD				SHEET	1	OF
APPD	Auric	02/28 2007				DRAWING NO.			JAH511C

03.05.2006

Page 2



Norddeutsche Affinerie AG
Hovestraße 50
D-20539 Hamburg
Telefon: 040/78 83-0
Telefax: 040/78 83-22 55

info@na-ag.com
www.na-ag.com

CERTIFICATE OF ANALYSIS

Freedom of Embrittlement

The freedom of embrittlement is tested according to ASTM B 577
(Closed Bend Test)

Typical Analysis (ppm):

Pb	Bi	As	Sb	Sn	Zn	Fe	Ni	AG	Se	Te	S	P
4	<1	3	3	<1	<3	8	8	12	<1	<1	8	appt. 30

The requirements are met.

The aforesaid data are given for purposes of technical quality
description only and do not constitute guaranteed properties in legal terms.

Irrevocable Doc. Credit Number 6AEJR10002201059 dated 060414
of Bank of Taiwan Taipei (Shihlin Branch)

NORDDEUTSCHE AFFINERIE
Aktiengesellschaft
Logistics Department

i.V. K. Tabel

Test Report

GWO CHERN INDUSTRIAL CO., LTD.
NO. 186-28, HAI HU VILLAGE, LU CHU HSIANG, TAO
YUAN HSIEN, TAIWAN

Report No. : CE/2006/75552
Date : 2006/07/26
Page : 1 of 3



The following sample(s) was/were submitted and identified by/on behalf of the client as :

Sample Description : JIS C1100
Sample Received : 2006/07/19
Testing Period : 2006/07/19 TO 2006/07/26

=====
Test Result(s) : - Please see the next page(s) -

Daniel Yeh, M.R. / Operation Manager
Signed for and on behalf of
SGS TAIWAN LTD.

Test Report

GWO CHERN INDUSTRIAL CO., LTD.
 NO. 186-28, HAI HU VILLAGE, LU CHU HSIANG, TAO
 YUAN HSIEN, TAIWAN

Report No. : CE/2006/75552
 Date : 2006/07/26
 Page : 2 of 3



Test Result(s)

PART NAME NO.1 : COPPER COLORED METAL

Test Item (s):	Unit	Method	MDL	Result
				No.1
Chromium VI (Cr+6)	ppm	UV-VIS(US EPA 7196A) after reference to US EPA 3060A.	2	N.D.
Cadmium (Cd)	ppm	ICP-AES after reference to EN 1122, method B:2001 or other acid digestion.	2	N.D.
Mercury (Hg)	ppm	ICP-AES after reference to US EPA 3052 or other acid digestion.	2	N.D.
Lead (Pb)	ppm	ICP-AES after reference to US EPA 3050B or other acid digestion.	2	8.2

NOTE: (1) N.D. = Not Detected (<MDL)
 (2) ppm = mg/kg
 (3) MDL = Method Detection Limit

Test Report

GWO CHERN INDUSTRIAL CO., LTD.
NO. 186-28, HAI HU VILLAGE, LU CHU HSIANG, TAO
YUAN HSIEN, TAIWAN

Report No. : CE/2006/75552

Date : 2006/07/26

Page : 3 of 3



** End of Report **

SPECIFICATIONS

TYPE DC BRUSHLESS FAN	MODEL NO. B127515BU AC	PAGE: 1 OF 4
---------------------------------	----------------------------------	------------------------

THESE SPECIFICATIONS DEFINE ELECTRICAL AND MECHANICAL CHARACTERISTICS OF THE DC BRUSHLESS FAN.

1. MECHANICAL SPECIFICATIONS

- | | |
|-------------------------|--------------------------------|
| 1-1 EXTERNAL DIMENSIONS | : REFER TO DWG. NO. HT-001 |
| 1-2 HOUSING MATERIAL | : LEAD-FREE PLASTIC {UL 94V-0} |
| IMPELLER MATERIAL | : LEAD-FREE PLASTIC {UL 94V-0} |
| 1-3 BEARING | : TWO BALL BEARINGS |
| 1-4 NET WEIGHT | : 79g |

2. ELECTRICAL SPECIFICATIONS

NO	ITEMS	STANDARD	REMARKS
2-1	RATED VOLTAGE	12 V DC	
2-2	START VOLTAGE	5 V DC	POWER ON/OFF
2-3	OPERATING RANGE	7 V~13.2 V DC	
2-4	CONSUMING CURRENT	0.80 Amp (MAX. 0.80 Amp)	IN FREE AIR AT RATED VOLTAGE
2-5	CONSUMING POWER	9.60 W (MAX. 9.60 W)	IN FREE AIR AT RATED VOLTAGE
2-6	RATED SPEED	5500rpm +/- 8%rpm	IN FREE AIR AT RATED VOLTAGE
2-7	AIRFLOW	MAX. 10.48CFM MAX. 0.30 m ³ /min	AT RATED VOLTAGE AT ZERO STATIC PRESSURE
2-8	STATIC PRESSURE	MAX.17.58 mmH ₂ O	AT RATED VOLTAGE AT ZERO AIRFLOW
2-9	SOUND LEVEL	51 dB(A)	IN FREE AIR AT RATED VOLTAGE

MICROPHONE FAN

EVERFLOW PRECISION ELECTRON CO., LTD	APPROVAL	CHECK	DESIGN
	LIU CHUN XIANG 2005/09/03	LIANG HAI HU 2005/09/03	HAI YING YANG 2005/09/03

SPECIFICATIONS

TYPE DC BRUSHLESS FAN	MODEL NO. B127515BU AC	PAGE: 2 OF 4
---------------------------------	----------------------------------	------------------------

2-10	OPERATING TEMPERATURE	-10°C~70°C (NORMAL HUMIDITY)	
2-11	STORAGE TEMPERATURE	-20°C~75°C (NORMAL HUMIDITY)	
2-12	DIRECTION OF ROTATION	CLOCKWISE FROM LABEL SIDE	
2-13	DIRECTION OF AIRFLOW	LABEL SIDE DISCHARGE	
2-14	INSULATION STRENGTH	10 MEG OHM MIN.	AT 500 VDC (BETWEEN FRAME AND (+) TERMINAL)
2-15	DIELECTRIC STRENGTH	MUST WITHSTAND 500 VAC 1min	MAX 1mA BETWEEN FRAME AND LEADS
2-16	PROTECTION	CURRENT LIMIT	
2-17	DROP TEST	IN MINIMUM PACKAGING CONDITION, FAN WITHSTANDS EACH ONE DROP OF THREE FACES FROM 30cm DISTANCE HEIGHT ON TO 10mm THICKNESS OF WOODEN BOARD.	
2-18	MECHANICAL SHOCK	TEMPERATURE : +25°c. ORIENTATION : X , Y , Z . POWER : NON-OPERATING., ACCELERATION : 20G MIN. PULSE : 11 MS HALF-SINE WAVE. NUMBER OF SHOCKS : 5 SHOCKS FOR EACH DIRECTION.	

NOTE 1. THE ABOVE STANDARD SHOULD BE THE SPECIFIED VALUE AT NORMAL TEMPERATURE (25°C) AND NORMAL HUMIDITY (60~65%) UNLESS OTHERWISE NOTICED.

EVERFLOW PRECISION ELECTRON CO., LTD	APPROVAL	CHECK	DESIGN
	LIU CHUN XIANG	LIANG HAI HU	HAI YING YANG
	2005/09/03	2005/09/03	2005/09/03

SPECIFICATIONS

TYPE DC BRUSHLESS FAN	MODEL NO. B 1 2 7 5 1 5 B U A C	PAGE: 3 OF 4
---------------------------------	---	------------------------

3.LIFE EXPECTANCE (MTBF)

MORE THAN 90% SHALL KEEP RUNNING AFTER CONTINUOUS OPERATION OF 50,000 HOURS AT RATED VOLTAGE IN 25°C AMBIENT TEMPERATURE AND 65% RELATIVE HUMIDITY CONDITION.
FAN LIFE SHOULD BE REDEFINED WHEN ABOVE CONDITIONS ARE CHANGED.

4.LOCKED ROTOR

NO DAMAGE SHALL BE FOUND FOR CONTINUOUS ONE HOUR AT LOCKED ROTOR.

5.SPECIAL ITEMS

5-1 SPECIFICATION CHANGE

ANY CHANGES TO THE PARAMETERS SPECIFIED IN THIS DOCUMENT WILL BE DETERMINED BY MUTUAL AGREEMENT ON BOTH PARTIES.

5-2 UNCERTAINTY

IN THE EVENT THAT ANY QUESTIONS MAY ARISE ABOUT THIS DOCUMENT OR ANY STATEMENTS NOT SPECIFIED IN THIS DOCUMENT BOTH PARTIES WILL DISCUSS AND DETERMINE A SOLUTION FAITHFULLY.

5-3 NOTE

1.PLEASE CONSIDER HAVING AN INDEPENDENT PROTECTION SYSTEM IN THE EVENT THAT THE FAN SHOULD STOP OPERATING.

2.PLEASE MAKE REFERENCE TO ATTACHED IMPORTANT NOTES & GENERAL INSTRUCTIONS AND DWG.No.:HT-001 TOGETHER WITH THIS SPECIFICATION.

EVERFLOW PRECISION ELECTRON CO., LTD	APPROVAL	CHECK	DESIGN
	LIU CHUN XIANG 2005/09/03	LIANG HAI HU 2005/09/03	HAI YING YANG 2005/09/03

SPECIFICATIONS

TYPE DC BRUSHLESS FAN	MODEL NO. B127515BU AC	PAGE: 4 OF 4
---------------------------------	----------------------------------	------------------------

6. PROVISION OF REVOLUTION SIGNAL

6-1 OUTPUT OF REVOLUTION SIGNAL

.OUTPUT TYPE
.ELECTRICAL SPECIFICATION

OPEN COLLECTOR TYPE

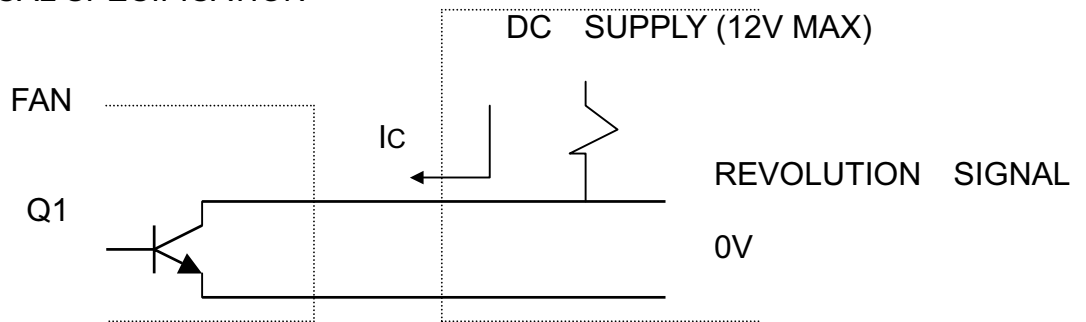

TRANSISTOR Q1 AT "ON" POSITION
COLLECTOR CURRENT SATURATION VOLTAGE BETWEEN COLLECTOR AND EMITTER AT $I_c = 10\text{mA MAX.}$

$I_c = 10\text{ mA MAX.}$
 $V_{oL} = 0.5\text{V MAX.}$

TRANSISTOR Q1 AT "OFF" POSITION
RELEASE VOLTAGE

$V_{oH} = 12\text{V MAX}$

6-2 OUTPUT WAVEFORM

(ACCORDING TO INPUT VOT.)

(AT REVOLUTION)

(AT LOCKED POSITION)

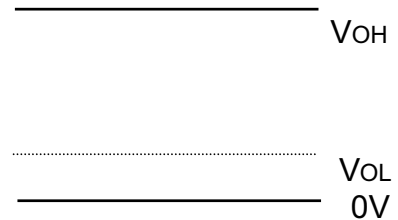
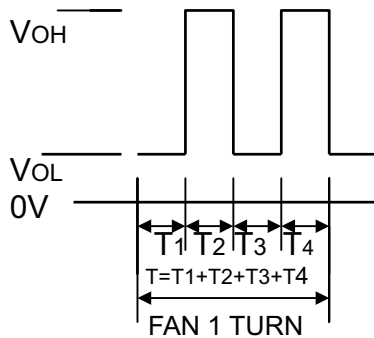

REMARK AT LOCKED POSITION, OUTPUT BECOMES V_{oH} OR V_{oL}

$T = T_1 + T_2 + T_3 + T_4 = 60/N$ (SEC) N : FAN SPEED (r.p.m)

$$\text{DUTY} = \frac{T_1}{T_1 + T_2} = 50 \pm 10\%$$

EVERFLOW PRECISION ELECTRON CO., LTD	APPROVAL	CHECK	DESIGN
	LIU CHUN XIANG 2005/09/03	LIANG HAI HU 2005/09/03	HAI YING YANG 2005/09/03

SPECIFICATIONS

IMPORTANT NOTES & GENERAL INSTRUCTIONS

1. Customer shall confirm the matching and reliability of fan on actual set or unit application.
This include confirmation on set or unit life, electrical noise, mechanical noise, vibration, static electricity, electric power noise, drift, electric resonance between motor and control circuit, mechanical resonance between motor and chassis, irregular movement of set due to motor noise, irregular movement of set in strong electromagnetic field, damaged by lightning surge earthing method etc.
2. Any revisions on the specification shall be done based on mutual discussion and agreement.
3. In order to improve the performance within the scope of specification, parts or material changes are subject to prior notice to customer.
4. Any item which is needed to add into specification shall be determined on customer's prior written request. If no information given, fan will be delivered based on our standard judgment.
5. When any trouble occurs, both parties shall discuss on this specification to solve the matters. In this case, our guarantee is only limited to fans.

EVERFLOW PRECISION ELECTRON CO., LTD	APPROVAL	CHECK	DESIGN
	LIU CHUN XIANG 2005/09/03	LIANG HAI HU 2005/09/03	HAI YING YANG 2005/09/03

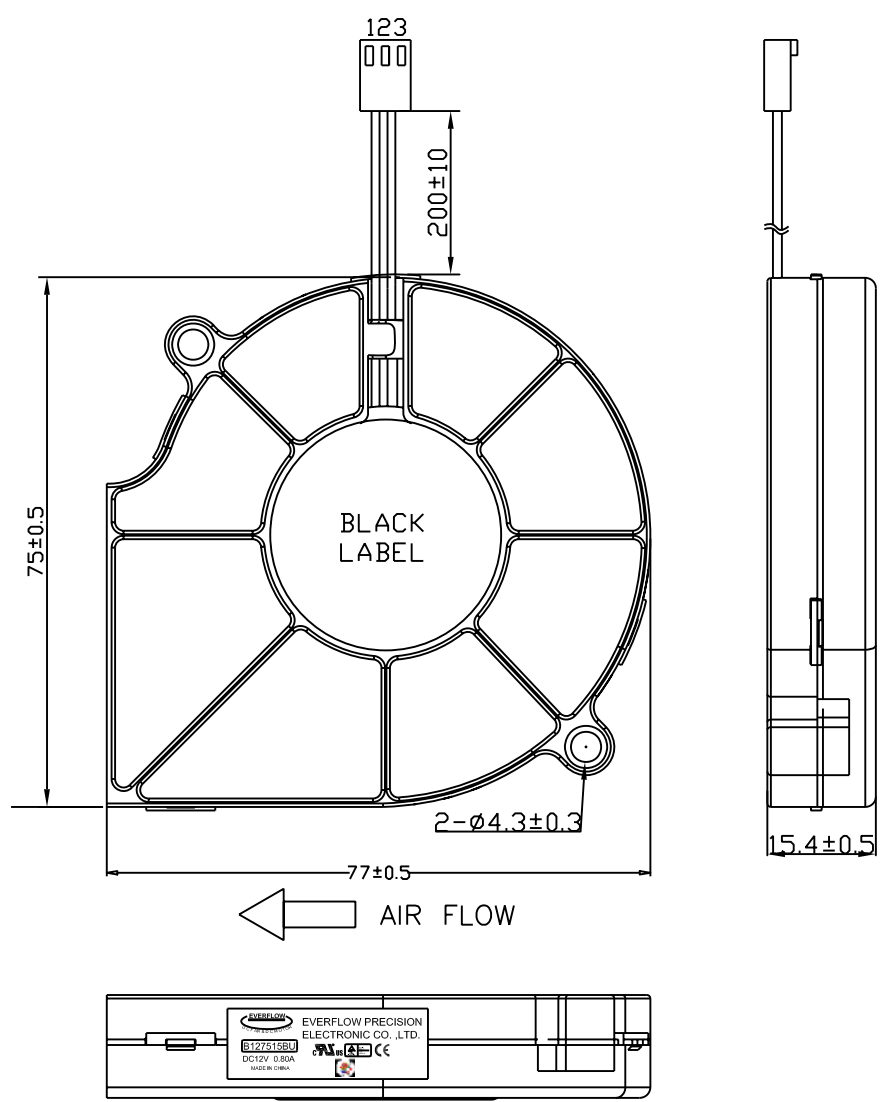

- NOTES:
- 1.LEAD WIRE UL1430 AWG26OR EQUIVALENT
PIN 1:BLACK WIRE---(-)
PIN 2:RED WIRE ---(+)
PIN 3.YELLOW WIRE---(SIGNAL)
 - 2.HOUSING:2510-3P OR EQUIVALENT
 - 3.TERMINAL:2515T OR EQUIVALENT

TRCANGLE METHOD		UNIT: mm		MODEL NO.	B127515BUAC6A302					
APPROVE	LIU CHUN XIANG	2006/01/07		PART NAME	DC FAN					
CHECK	LIANG HAI HU	2006/01/07			DRAWING NAME	OUTLINE				
DRAWING	HAI YING YANG	2006/01/07								
EVERFLOW PRECISION ELECTRON CO.,LTD.		CODE	HT - 001			PAGE: 1				

EVERFLOW FAN LIFE TEST REPORT

B127515BU AC

1. Test Conditions

EVERFLOW Axial Fan P/N B127515BU AC rotates continuously under the following conditions:

- a. Ambient Temperature=70deg.C/RH65%.
- b. Voltage Applied=12V
- c. Number of Fan Tested =10PCS

2. Estimated life

Everflow definition of life is when fan reaches the end of its' life, the rotation speed of fan decreases by under 20% comparing with its original rotation speed at start.

3. Acceleration Test Result

- a. Running continuously for 15,800Hrs at temperature 70°C without deterioration of rotation speed more than 20%.
- b. Test data as attached.

4. Fan Life Estimate(L10)

Following is calculation formula to be applied to estimate the life of fan at 25deg. C ambient temperature .

a. Accelerated Test Temperature=70 deg.C

b. Calculation Formula

$$L10 = T_{70} \times \text{EXP} \left[\frac{EA}{K} \left(\frac{1}{TU} - \frac{1}{TA} \right) \right]$$

where each alphabetical symbol means as follows:

L10=Life at 25 deg. C ambient temperature.

T₇₀=life at 70 deg.C ambient temperature

EA=Action energy(0.3~0.5) fan & motor : 0.4

K=Boltemanns constant 8.63×10⁻⁵

TU=Absolute temperature of using

TA=Absolute temperature of testing

c. Calculation Result

L10=121,502Hrs

Test Data for B127515BU AC

B127515BU AC life test data as below:

ambient temperature:70°C 15,800Hrs N= 10PCS

Rated Voltage:12V

Rated Temperature:25°C

Test Temperature:70°C

Test Equipment

Equipment	Brand/Model	Specification
DC power supply	TES-6210	Voltage:0~30V Current: 0~3A
Flasher	SP-DS220A	Range:300~30000rpm
Temperature/Humidity Cycling Chanber	GTH-099-40-1P	-20°C~100°C R.H.20%-98%
Vibration Tester	King Dsign KD-9363	2-2000HZ
Thermal Shock Tester	Giant Force GTST-108-65	-65°C~150°C

Test data & Test result

70deg C N=10PCS

No.	Before test data		After test data	
	Speed(RPM)	Current(Amp)	Speed(RPM)	Current(Amp)
1	5486	0.56	5511	0.55
2	5478	0.57	5486	0.56
3	5468	0.58	5489	0.57
4	5320	0.57	5389	0.55
5	5426	0.57	5268	0.57
6	5392	0.56	4293	0.67
7	5398	0.58	5479	0.58
8	5472	0.56	5378	0.58
9	5326	0.57	5296	0.56
10	5400	0.58	5359	0.59

NO.6 was found rotation speed has deteriorated more than 20% and current has risen 15% when it run continuously for 15,800 hours at temperature 70°C.

It was show fan has reached the end of its' life.



S&E Technologies Laboratory

Certification of Conformity

Date of Issue: September 23, 2005

Attestation number: SE05I-173S

S&E Technologies Laboratory Ltd. hereby declares that testing has been completed and reports have been generated for:

Product: DC FAN

Model: X1X2X3X4X5X6

Note: Model designation see attachment

Applicant: EVERFLOW PRECISION ELECTRONIC(DONGGUAN) CO.,LTD

Gekeng Yanjiang Industrial Zone, Heng Li Town, Dong Guan City,
Guang Dong Province, China

Manufacturer: EVERFLOW PRECISION ELECTRONIC(DONGGUAN) CO.,LTD

Gekeng Yanjiang Industrial Zone, Heng Li Town, Dong Guan City,
Guang Dong Province, China

And, in accordance to the following Applicable directives:

73/23/EEC Low Voltage Directive (as amended)

That this product has been assessed against the following Applicable Standards;

LVD EN 60950-1: 2001

Therefore, S&E Technologies hereby acknowledges that the applicant may issue a DECLARATION of CONFORMITY and apply the CE mark in accordance to European Union Rules.

Attestation by: Karbon Y. Chung

Signature



Page 1 of 3

CE The CE marking may only be used if all relevant and effective EC Directives are complied with. CE

Tel: 86-755-26636573 Fax: 86-755-26630557 <http://www.seps.com.cn>



S&E Technologies Laboratory

Certification of Conformity

Date of Issue: September 23, 2005

Attestation number: SE05I-173S

Attachment

Model Designation: X1X2X3X4X5X6

X1 = Frame Type (R, F, T, S, B, K, X)

X2 = Input Voltage (B=12V DC, C=24V DC)

X3 = Size of Fan (60, 70, 75, 80, 90, 92, 120)

X4 = Thickness of Fan (10, 15, 20, 25, 30, 32, 38)

X5 = B or II

(B=Two ball II= S: One sleeve; D: One ball one sleeve; B: Two ball)

X6 = Speed

(L=Low speed; M=Medium speed; H=High speed; U=Ultra high speed)

Model Name	Voltage (V)	Current (A)	Speed (RPM)
R(S/T)B6010 II U(55)	12	0.35	5500
(R/F/T)C6025 II L	24	0.14	3600
(R/F/T)C6025 II M	24	0.16	4000
(R/F/T)C6025 II H	24	0.20	4550
(R/F/T)C6025 II U	24	0.25	4900
RB7038BL	12	0.28	3800
RB7038BM	12	0.35	4800
RB7038BH	12	0.50	5800
RB7038BU	12	0.80	6800
RB8020 II L	12	0.20	2400
RB8020 II M	12	0.40	3600
RB8020 II H	12	0.55	4200
RB8020BU	12	1.00	4800
RC8032 II L	24	0.20	3000
RC8032 II M	24	0.25	3600

Page 2 of 3

CE The CE marking may only be used if all relevant and effective EC Directives are complied with. CE

Tel: 86-755-26636573 Fax: 86-755-26630557 <http://www.seps.com.cn>



S&E Technologies Laboratory

Certification of Conformity

Date of Issue: September 23, 2005

Attestation number: SE05I-173S

Continuation

Model Name	Voltage (V)	Current (A)	Speed (RPM)
RC8032 II H	24	0.30	4200
RC8032 II U	24	0.40	4800
FB8038BL	12	0.18	3000
FB8038BM	12	0.25	3600
FB8038BH	12	0.30	4200
FB8038BU	12	0.50	4800
FC9025 II L	24	0.12	2200
FC9025 II M	24	0.18	2800
FC9025 II H	24	0.25	3200
FC9025 II U	24	0.35	3600
FB9238BL	12	0.50	3200
FB9238BM	12	0.70	3600
FB9238BH	12	0.80	4200
FB9238BU	12	1.20	4800
FB1232BL	12	0.25	1800
FB1232BM	12	0.50	2200
FB1232BH	12	0.65	2600
FB1232BU	12	1.00	3000
BB7515BL	12	0.40	4000
BB7515BM	12	0.50	4500
BB7515BH	12	0.60	5000
BB7515BU	12	0.80	5500
BB7530BU	12	0.42	3800

Page 3 of 3

CE The CE marking may only be used if all relevant and effective EC Directives are complied with. CE

Tel: 86-755-26636573 Fax: 86-755-26630557 <http://www.seps.com.cn>



Suzhou New & Hi Tech Industrial Park
 85 Hongqian Road, Block 3
 Suzhou, Suzhou New District
 Jiangsu 215009, CHINA
 Tel: +86 512 6808 6400
 Fax: +86 512 6808 4099
 www.Ul-CCIC.com

MR. JANICE
 EVERFLOW PRECISION ELECTRONIC (HONG
 KONG) CO LTD
 GE KENG INDUSTRIAL ZONE
 HENG LI TOWN
 DONGGUAN,
 GUANGDONG 523460 CHINA

Date: 2005/06/03
 Subscriber: 762737001
 File No: E236658
 Project No: 05CM29583
 PO No: 05018252
 Type: R
 PO Number: LIUCHUN XIANG

Subject: Procedure And/Or Report Material

The following material resulting from the investigation under the above numbers is enclosed.

Issue			Pages		Revised Date
Date	Vol	Sec	New	Index Page (s)	
2003/06/27	1			2	
2005/07/29	1	7		Add New Proc./Support Sect.	2005/07/29

Inspections at your plant will be conducted under the supervision of Mr. Li Wei Qun, China National Import & Export Commodities Inspection Corp. (CCIC), 5th Floor, Zhong Chang Bldg., No. 6, Li Cheng Rd, Changping Town, Dongguan, Guangdong 523565, China. PHONE: +86-769-381-7010, 7011, 7012, 7013, 7015, FAX: +86 769 381 7017, E-MAIL: ulic213@ul-ccic.com

Please file revised pages and illustrations in place of material of like identity. New material should be filed in its proper numerical order.

NOTE: Follow-Up Service Procedure revisions DO NOT include Cover Pages, Test Records and Conclusion Pages. Report revisions DO NOT include Authorization Pages, Indices, Section General Pages and Appendixes.

Please review this material and report any inaccuracies to Ul China (Suzhou) Customer Service, PHONE: +86-512-6808-6400, FAX: +86-512-6808-4099, E-MAIL: customerservice.sz@cn.ul.com, referring to the above Project and/or PO Numbers.

This material is sent on behalf of Underwriters Laboratories Inc. pursuant to the Services Undertaking and Business Transfer Agreement between this affiliate and UL.

TPI File

UL INSPECTION CENTER 213

Models	V dc	A
FB9238BL	12	
FB9238BM	12	0.40
FB9238BH	12	0.60
FB9238BU	12	0.80
		1.00
FB1232BL	12	
FB1232BM	12	0.25
FB1232BH	12	0.50
FB1232BU	12	0.65
		1.00
BB7515BL	12	
BB7515BM	12	0.40
BB7515BH	12	0.50
BB7515BU	12	0.60
		0.80

Note: Above (W) may be R, S or T; (X) may be R, F or T; (Y) may be S, D or B.

Zertifikat

Certificate



Zertifikat Nr. Certificate No.
R 50040385

Blatt Page
0002

Ihr Zeichen Client Reference
XLU

Unser Zeichen Our Reference
ZTW1-JPE- 10009602 002

Ausstellungsdatum
16.08.2005

Date of Issue
(day/month/year)

Genehmigungsinhaber License Holder
Everflow Precision Electronic
(Dong Guan) Co., Ltd.
GeKeng Industrial Zone
Heng Li Town
Dongguan City, Guangdong 523460
P.R. China

Fertigungsstätte Manufacturing Plant
Everflow Precision Electronic
(Dong Guan) Co., Ltd.
GeKeng Industrial Zone
Heng Li Town
Dongguan City, Guangdong 523460
P.R. China

Prüfzeichen Test Mark

Geprüft nach Tested acc. to
EN 60950:2000



Zertifiziertes Produkt (Geräteidentifikation)
Certified Product (Product Identification)

Lizenzentgelte - Einheit
License Fee - Unit

Ventilator (DC Fan)

wie Blatt (as page) 01
Ergänzung (Addition)

Bezeichnung : X1X2X3X4X5X6 (EVERFLOW)
(Type Designation)

X1 steht für (stands for): R, F, S, B, X, T, K oder (or) D	1
X2 steht für (stands for): B oder (or) C	1
X3 steht für (stands for): 60, 70, 75, 80, 90, 92 oder (or) 12	1
X4 steht für (stands for): 10, 15, 20, 25, 30, 32 oder (or) 38	1
X5 steht für (stands for): B oder (or) II	1
X6 steht für (stands for): L, M, H oder (or) U	1
Nennspannung (Rated Voltage): DC 12V oder (or) 24V	
Nennstrom : siehe Anlage (Rated Current) (see Appendix)	

Hinweis: Dieses Ausweisblatt ersetzt Zertifikat R50040385,
Blatt 02 vom 04.08.2005.
(Remark: This license sheet replaces certificate R50040385,
sheet 02 dated 04.08.2005.)



ANLAGE (Appendix): 1

Dem Zertifikat liegt unsere Prüf- und Zertifizierungsordnung zugrunde.
Das Produkt entspricht den o.g. Anforderungen, die Herstellung wird überwacht.
This certificate is based on our Testing and Certification Regulation. The product
fulfills above-mentioned requirements, the production is subject to surveillance.

Zertifizierungsstelle

TÜV Rheinland Product Safety GmbH, Am Grauen Stein, D-51105 Köln

Tel.: (+49/221) 8 06 - 13 71 Fax: (+49/221) 8 06 - 39 35 e-mail: Althuff@de.tuv.com

Dipl.-Ing. F. Spoelzel



Appendix to TÜV Bauart approved Certificate No.: R 50040385

Kind of equipment : DC Fan
 Report number : 10009602 002
 Model Name : X1X2X3X4X5X6
 (X1 = R, F, S, B, X, T, K, D (frame type); X2 = B or C, B = 12V, C = 24V (operating voltage); X3 = 60, 70, 75, 80, 90, 92 or 12 (size); X4 = 10, 15, 20, 25, 30, 32 or 38 (thickness); X5 = B or II, B = two ball, II = S (one sleeve), ~~B~~ (two ball) or D (one ball and one sleeve); X6 = L (low speed), M (Medium speed), H (High speed), U (Ultra High speed))

Series	Model No.	Voltage DC (V)	Current (A)
9238	FB9238BH	12	0.80
	FB9238BU	12	1.20
1232	FB1232BL	12	0.25
	FB1232BM	12	0.50
	FB1232BH	12	0.65
	FB1232BU	12	1.00
	BB7515BL	12	0.40
7515	BB7515BM	12	0.50
	BB7515BH	12	0.60
	BB7515BU	12	0.80
	BB7530BU	12	0.42

Date: August 16, 2005

Certification Body

F. Stözel
 Dipl.-Ing. Friedrich Stözel



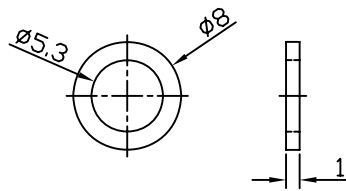
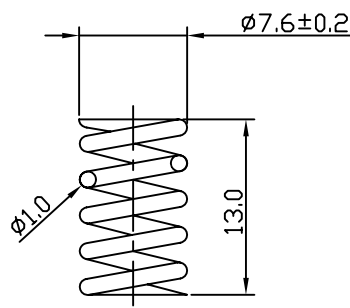
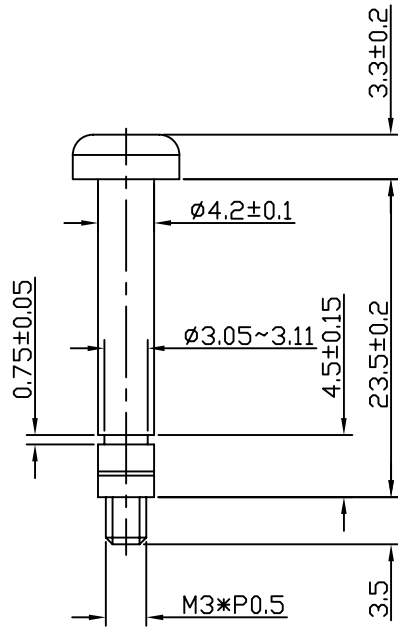
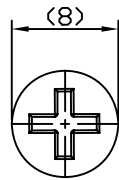

MODEL	JAS175C-A		NAME	Spring Screw Kit					
DRN	Tony	02/27/2007	MATERIAL	-----		REV.	DESCRIPTION	SIGN	DATE
DSN	John	02/27/2007	FINISH	-----			DIM IN	mm	DO NOT SCALE DWG
CKD	Richard	02/27/2007	CHIA CHERNE INDUSTRY CO.,LTD				SHEET	1	OF
APPD	Auric	02/27/2007				DRAWING NO.			JAS175C-A

中國鋼鐵股份有限公司

CHINA STEEL CORPORATION

品質證明書

TEST CERTIFICATE

中華民國高雄市小港區中鋼路1號
 LIAO HAI INDUSTRIAL DISTRICT P.O. BOX 4
 HSIAO KANG, KAOSIUNG(812),
 TAIWAN, REPUBLIC OF CHINA
 TELE: 71108, 71283, 71415 KAOSIUNG
 TEL: (07)802-1111 FAX: (07)803-0927

FROM : TSLZ MENG

客戶名稱 SOLD TO	泰河工廠股份有限公司 CHUN YU WORKS & CO., LTD. 1, CHIA HSIN RD., CHIA HSIN LI, KANG SHAN CHENG, KAO, HSIEH		產品名稱 PRODUCT	ROD-CARBON STEEL	證明書編號 CERTIFICATE NO.	B70225B
規格代碼 SPEC	AISI 1018, AL-KILLED (BCW02)		客戶編號 CUSTOMER NO.	88167108	中鋼訂至編號 SERIALIZED NO.	JB5002Z
檢驗 SPEC	CSC MILL INSPECTION		交運日期 SHIPPING DATE		證明書日期 VTC ISSUE DATE	
T/C 02			客戶訂單編號 ORDER NO.	D01206		

項目 ITEM NO.	產品序號 SEQ. NO.	尺寸 DIMENSION	規格 SPECIFICATION	重量 WEIGHT	爐號 HEAT NO.	拉伸試驗 TENSILE	屈服 Y.S.	抗拉 T.S.	伸長 EL.	化學成份 CHEMICAL ANALYSIS %			備註 REMARKS			
										C	MN	P		S	SI	CU
D05	D3851 01	7.00	TOTAL:	12	17.713	12	17.713			18	74	20	9	7	66	
SPECIFICATION																

NOTE: (1) CHEMICAL ANALYSIS IS CARRIED OUT BY CSC IN ACCORDANCE WITH TEST METHOD ASTM E415 AND E1019 WHICH CONFORM TO METAL STANDARDS AND SPECIFICATIONS.
 (2) TEST SAMPLES ARE DISC TYPE (3) TEST REPORT RELATES ONLY TO THE SAMPLES BEING TESTED AND THAT SMALL MAY NOT BE PARALLEL REASONING

茲證明本廠所生產之產品，均依材料規格製造及試驗，並符合規格之要求。且經本公司試驗，其品質符合本廠之要求。且經本公司試驗，其品質符合本廠之要求。且經本公司試驗，其品質符合本廠之要求。

WE HEREBY CERTIFY THAT MATERIAL DESCRIBED HEREIN HAS BEEN MANUFACTURED AND TESTED WITH SATISFACTORY RESULTS IN ACCORDANCE WITH THE REQUIREMENT OF THE ABOVE MATERIAL SPECIFICATION.

Yong Hwa Chung

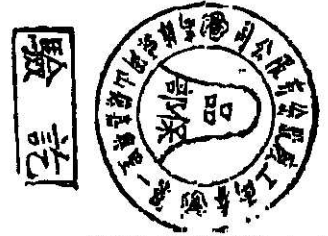

驗記

Test Report

CHUNG YIN SPRING INDUSTRIAL CO., LTD.
 36, ALLEY 42, CHUNG HSIN N. ST., SAN CHUNG CITY,
 TAIPEI HSIEN, TAIWAN, R. O. C.

Report No. : CE/2005/90301
 Date : 2005/09/07
 Page : 1 of 1

The following merchandise was (were) submitted and identified by the client as :

Type of Product : SAE1018-Ni
Sample Received : 2005/08/31
Testing Date : 2005/08/31 TO 2005/09/07

Test Result

PART NAME NO.1 : SILVER COLORED METAL

Test Item (s):	Unit	Method	MDL	Result
				No.1
Chromium VI (Cr+6)	ppm	UV-VIS after reference to US EPA 3060A.	2	N.D.
Cadmium (Cd)	ppm	ICP-AES after reference to EN 1122, method B:2001 or other acid digestion.	2	N.D.
Mercury (Hg)	ppm	ICP-AES after reference to US EPA 3052 or other acid digestion.	2	N.D.
Lead (Pb)	ppm	ICP-AES after reference to US EPA 3050B or other acid digestion.	2	N.D.

NOTE: (1) N.D. = Not detected (<MDL)
 (2) ppm = mg/kg
 (3) MDL = Method Detection Limit

 Daniel Yeh, M.R. / Operation Manager
 Signed for and on behalf of
 SGS TAIWAN LTD.



廣泰金屬工業股份有限公司

KUANG TAI METAL IND. CO., LTD.

No. 20 Kung Yen Road, Erh Chen Tsun,
Kuan Tien Hsiang, Tainan Hsien, Taiwan, R.O.C.
TEL: 886-6-6987615-9 FAX: 886-6-6988792, 6987315

MILL CERTIFICATE 材質證明

Date 日期: 05/09/2005

Article 產品/品名	Carbon Steel Spring Wire (KH-3)				
Mfg. Date 製造日期	04/02/2005	Grade 等級	SW-C	Quantity 數量	58coils.
Cert. No. 材證號	DM1-540025	Size 尺寸	1.0 mm	Net Weight 淨重	2858.8 Kgs.
Customer 客戶	盈豪五金有限公司				

CHEMICAL COMPOSITION 化學成份

Component 成份	C	Mn	Si	P	S	Al			
Specification % 適用規範 (JIS G3506 SWRH 82B)	0.79- 0.86	0.60- 0.90	0.15- 0.35	0.030 max	0.030 max				
Heat No 2M708	0.82	0.83	0.22	0.015	0.003	-			

MECHANICAL PROPERTIES 機械性能

標準 Requirement	Diameter 線徑 mm	Tensile Strength 抗拉強度 Kg/mm ²	Surface 表面狀態			
Test 測試	±0.030	1720-1960				
01	1.001	1896	GOOD			
02	1.000	1910	GOOD			

KUANG TAI METAL IND. CO., LTD.

C. W. Ho

Quality Assurance Department.

Test Report

CHUNG YIN SPRING INDUSTRIAL CO., LTD.
 36, ALLEY 42, CHUNG HSIN N. ST., SAN CHUNG CITY,
 TAIPEI HSIEN, TAIWAN, R. O. C.

Report No. : CE/2005/90300
 Date : 2005/09/07
 Page : 1 of 1

The following merchandise was (were) submitted and identified by the client as :

Type of Product : SWC-Ni
Sample Received : 2005/08/31
Testing Date : 2005/08/31 TO 2005/09/07

Test Result

PART NAME NO.1 : SILVER COLORED METAL

Test Item (s):	Unit	Method	MDL	Result
				No.1
Chromium VI (Cr+6)	ppm	UV-VIS after reference to US EPA 3060A.	2	N.D.
Cadmium (Cd)	ppm	ICP-AES after reference to EN 1122, method B:2001 or other acid digestion.	2	N.D.
Mercury (Hg)	ppm	ICP-AES after reference to US EPA 3052 or other acid digestion.	2	N.D.
Lead (Pb)	ppm	ICP-AES after reference to US EPA 3050B or other acid digestion.	2	N.D.

NOTE: (1) N.D. = Not detected (<MDL)
 (2) ppm = mg/kg
 (3) MDL = Method Detection Limit

 Daniel Yen, M.R. / Operation Manager
 Signed for and on behalf of
 SGS TAIWAN LTD.

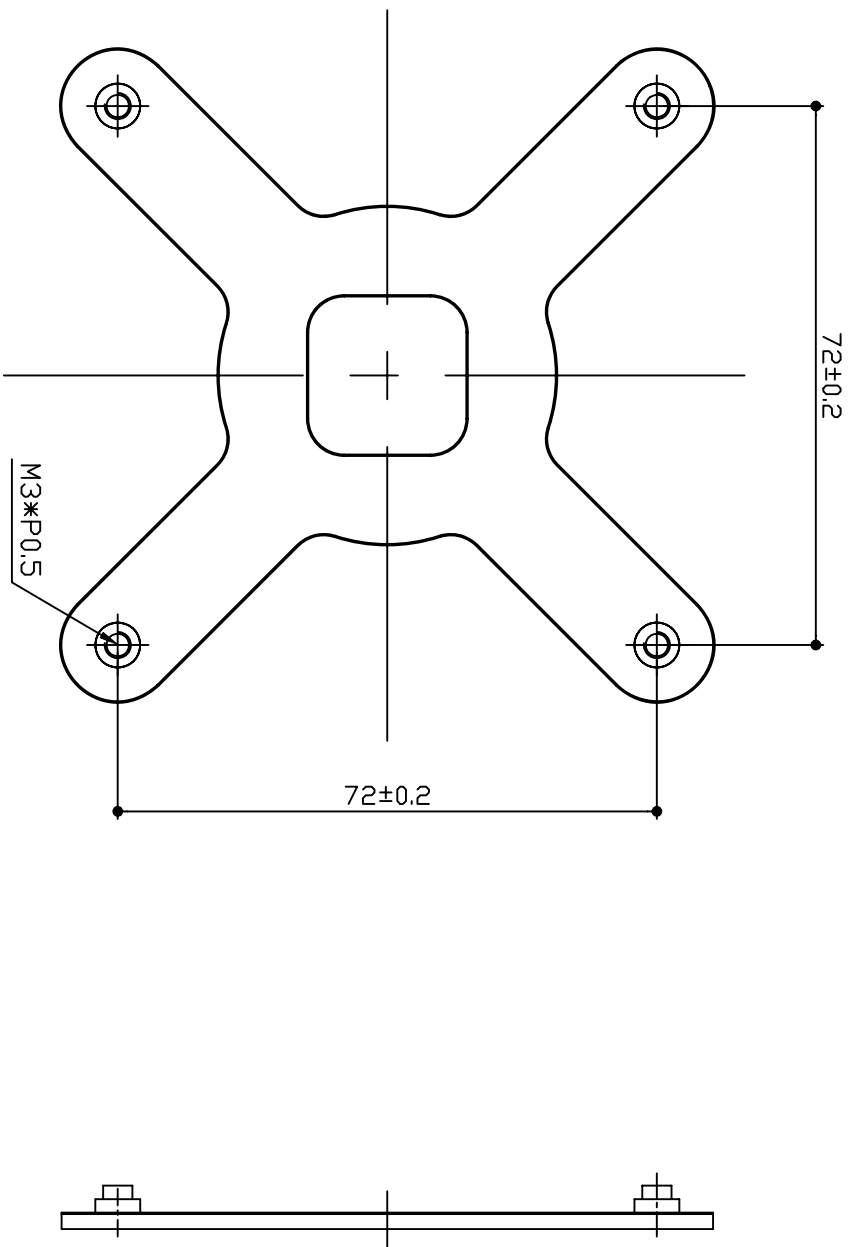

RANGE	TOL #										URS
	M1	M2	S1	S2	P1	P2	C	URS	URS	URS	
0~6	0.05	0.10	0.15	0.20	0.05	0.10	0.50	0.20			
6~30	0.10	0.20	0.15	0.25	0.10	0.15	1.00	0.25			
30~120	0.15	0.25	0.20	0.30	0.20	0.40	2.00	0.45			
120~300	0.15	0.30	0.25	0.45	0.40	0.80	3.00	0.80			
300~600	0.20	0.50	0.40	0.60	0.60	1.20	3.00	1.20			
600~1200	0.30	0.80	0.70	1.10	0.80	1.50	4.00	1.50			

MODEL	NAME
JAT095	Back Plate
DRN	Fanny
DSN	John
CKD	Richard
APPD	Auric
	CHIA CHERNE INDUSTRY CO.,LTD

REV.	DESCRIPTION	SIGN	DATE

DIM IN	mm	DD NOT SCALE	DWG
SHEET	1	DF	1

DRAWING NO. **JAT095**

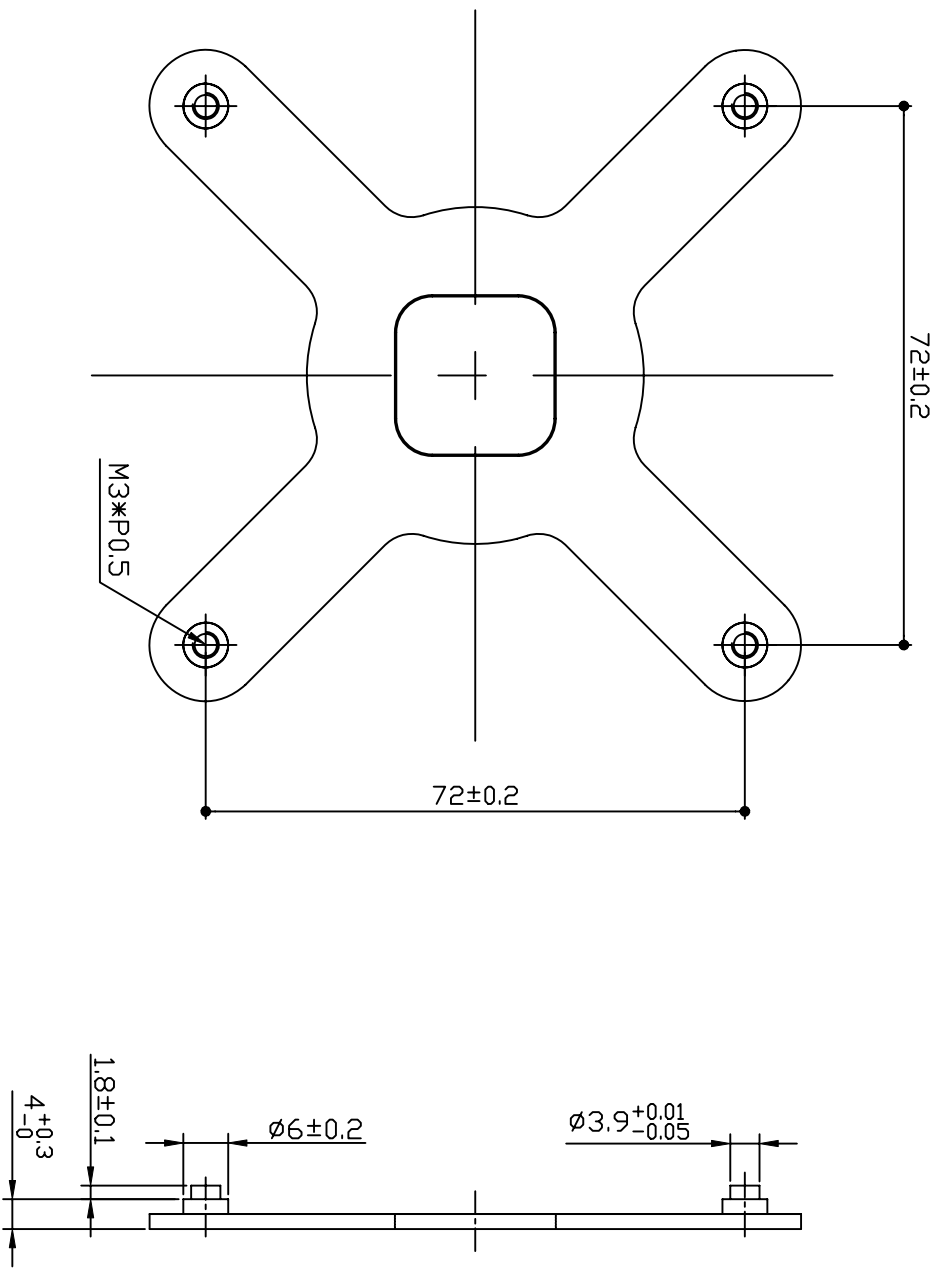

RANGE	TOL #										URS
	M1	M2	S1	S2	P1	P2	C	URS	URS	URS	
0~6	0.05	0.10	0.15	0.20	0.05	0.10	0.50	0.20			
6~30	0.10	0.20	0.15	0.25	0.10	0.15	1.00	0.25			
30~120	0.15	0.25	0.20	0.30	0.20	0.40	2.00	0.45			
120~300	0.15	0.30	0.25	0.45	0.40	0.80	3.00	0.80			
300~600	0.20	0.50	0.40	0.60	0.60	1.20	3.00	1.20			
600~1200	0.30	0.80	0.70	1.10	0.80	1.50	4.00	1.50			

MODEL	NAME
JAT095-1	Back Plate
DRN	Fanny
DSN	John
CKD	Richard
APPD	Auric
MATERIAL	---
FINISH	---
CHIA CHERNE INDUSTRY CO.,LTD	

REV.	DESCRIPTION	SIGNATURE	DATE

DIM IN	mm	DD NOT SCALE	DWG
SHEET	1	DF	1

DRAWING NO. JAT095-1

聯隆企業股份有限公司
YEN LONG ENTERPRISE CO., LTD.

品質證明書

中華民國臺灣高雄縣橋頭鎮林子五村字第011號
517, YU LIAO ROAD, CHIAO TOW HSIANG,
KAOHSIUNG HSIEH, TAIWAN, R.O.C.
TEL: (87) 611-7171 (13 LINES) FAX: (87) 611-6564

客戶名稱 SOLD TO		證明書編號 CERTIFICATE NO.	02040035	證明書日期 ISSUE DATE	2002-04-02
產品名稱 COMMODITY	冷軋厚板	訂單號碼 ORDER NO.		交運日期 SHIPPING DATE	2002-04-01
產品規格 SPECIFICATION	JIS G3141 SPC-SEC	客戶編號 CUSTOMER NO.	130137	發票號碼 INVOICE NO.	

項目 ITEM NO.	鋼捲編號 COIL NO.	試片編號 SAMPLE NO.	尺寸規格 MATERIAL DESCRIPTION					重量 WEIGHT	爐號 HEAT NO.	此項試驗項目 TEST				化學成份 CHEMICAL COMPOSITION %								
			厚度 THICK	寬度 WIDTH	長度 LENGTH	重量 WT	單位 UNIT			機械 MECH	物理 PHYS	化學 CHEM	其他 OTHER		C	Mn	Si	P	S	Cu	Ni	Cr

SPECIFICATION																												
01	131351A001		.600	1229			6090	45553																				
02	131367A005		1.150	1219			9505	63985																				
03	131398A005		1.150	1219			9590	45939																				
04	131382A005		1.150	1219			9030	57215																				
05	131982A005		.980	1219			8955	0261705																				
06	131957A005		.900	1219			9000	0294725																				
TOTAL WEIGHT:		58130																										
IMP: FOR REFERENCE ONLY																												

SUBVENOR TO

茲證明本表所列製品，均係材料規格製造及試驗，並符合規格之要求。

WE HEREBY CERTIFY THAT MATERIAL DESCRIBED HEREON HAS BEEN MANUFACTURED AND TESTED WITH SATISFACTORY RESULTS IN ACCORDANCE WITH THE REQUIREMENT OF THE ABOVE MATERIAL SPECIFICATION.

YEN LONG ENTERPRISE CO., LTD.
DEPUTY SUPERINTENDENT
CHIAO-BING HUBBS

APPLICANT: TONG YU INDUSTRY CO., LTD
NO2-32 LANE 518
SEC 3 CHUNGSHAN RD
CHANGHUA CITY CHANGHUA COUNTY 500
TAIWAN R.O.C.

DATE : JAN 06, 2006

SAMPLE DESCRIPTION:

ONE (1) GROUP OF SUBMITTED SAMPLES SAID TO BE :
SAMPLE DESCRIPTION : JIS G3141 SERIES + ANODIZING BLACK
DATE SAMPLE RECEIVED : DEC 30, 2005
DATE TEST STARTED : DEC 30, 2005

TESTS CONDUCTED:

AS REQUESTED BY THE APPLICANT, FOR DETAILS PLEASE REFER TO ATTACHED PAGES.

PREPARED AND CHECKED BY:
FOR INTERTEK TESTING SERVICES
TAIWAN LIMITED



JACOB LIN
GENERAL MANAGER

TESTS CONDUCTED

(A) TEST RESULT SUMMARY :

TESTING ITEM	RESULT (ppm)
	SUBMITTED SAMPLES
CADMIUM (Cd) CONTENT	ND
LEAD (Pb) CONTENT	26
MERCURY (Hg) CONTENT	ND
CHROMIUM VI (Cr ⁶⁺) CONTENT	ND

REMARKS : ppm = PARTS PER MILLION
 ND = NOT DETECTED

(B) TEST METHOD :

TESTING ITEM	TESTING METHOD	REPORTING LIMIT
CADMIUM (Cd) CONTENT	WITH REFERENCE TO USEPA 3052, BY MICROWAVE DIGESTION AND DETERMINED BY ICP-OES	2 ppm
LEAD (Pb) CONTENT	WITH REFERENCE TO USEPA 3052, BY MICROWAVE DIGESTION AND DETERMINED BY ICP-OES	2 ppm
MERCURY (Hg) CONTENT	WITH REFERENCE TO USEPA 3052, BY MICROWAVE DIGESTION AND DETERMINED BY ICP-OES	2 ppm
CHROMIUM VI (Cr ⁶⁺) CONTENT	WITH REFERENCE TO USEPA 3060A & 7196A, BY ALKALINE DIGESTION AND DETERMINED BY UV-VIS	1 ppm

REMARK : REPORTING LIMIT = QUANTITATION LIMIT OF ANALYTE IN SAMPLE

 END OF REPORT



品質證明書 TEST CERTIFICATE

CHINA STEEL CORPORATION
中華人民共和國唐山市中國鋼鐵
TUNGSHAN IRON AND STEEL CO., LTD.
DANANG, REPUBLIC OF CHINA
TEL: 8620221111 FAX: 8620211120728014927

240610

客戶名稱
CAMELIA METAL CO., LTD.
NO. 5011, 2, CHANG HUA RD., CHANG LI, TAINAN

規格名稱
SAE 1045 (GRT)

檢驗標準
CSC MILL INSPECTION

T/C 01

產品名稱	RD-82PWKSPH08123HLENH1PW1ZED STEEL
產品規格	F854000779
客戶名稱	中國鋼鐵
交貨日期	2005.08.20
客戶訂單編號	804.20.2005
證明書日期	2005.08.21

項目	單位	規格	檢驗結果	備註
屈服強度	MPa	355	355	
抗拉強度	MPa	510	510	
斷後伸长率	%	22	22	
断面收缩率	%	56	56	
硬度	HRB	215	215	

C	0.025
P	0.025
S	0.025
Mn	0.025
Si	0.025
Al	0.025
Ca	0.025
Fe	0.025
其他	0.025

項目	單位	規格	檢驗結果	備註
屈服強度	MPa	355	355	
抗拉強度	MPa	510	510	
斷後伸长率	%	22	22	
断面收缩率	%	56	56	
硬度	HRB	215	215	

此證明書所列產品，均經本廠檢驗合格。其材料之性能，業經本廠試驗，其結果與本廠之規定相符。本廠之產品，均經本廠檢驗合格。其材料之性能，業經本廠試驗，其結果與本廠之規定相符。

成分查符

Yehjung

CHINA IRON AND STEEL CORPORATION

Test Report

藝祺有限公司
彰化縣埔鹽鄉彰水路一段107號

報告號碼 : CE/2005/95071
日期 : 2005/09/30
頁數 : 1 of 2

以下測試樣品乃供應廠商所提供及確認：

樣品名稱 : SAE1215 SERIES
收件日期 : 2005/09/23.
測試日期 : 2005/09/23 TO 2005/09/30

測試結果

測試部位 NO.1 : 鐵灰色金屬(請參照附件圖片)

測試項目：	單位	測試方法	偵測極限值	結果
				NO.1
六價鉻	ppm	依照US EPA 3060A方法, 用UV-VIS 做分析	2	N.D.
鎘	ppm	依照 EN1122 方法B:2001或其他酸 消化方法,用感應耦合電漿原子發 射光譜儀(ICP-AES)做分析	2	N.D.
汞	ppm	依照 US EPA 3052 方法或其他酸 消化方法,用感應耦合電漿原子發 射光譜儀(ICP-AES)做分析	2	N.D.
鉛	ppm	依照 US EPA 3050B 方法或其他酸 消化方法,用感應耦合電漿原子發 射光譜儀(ICP-AES)做分析	2	15.3

備註：(1) N.D. = Not detected.(<MDL) / 未檢出(低於偵測極限值)
(2) ppm = mg/kg / 百萬分之一
(3) MDL= Method Detection Limit(偵測極限值)

Daniel Yeh, M.R. / Operation Manager
Signed for and on behalf of
SGS TAIWAN LTD.

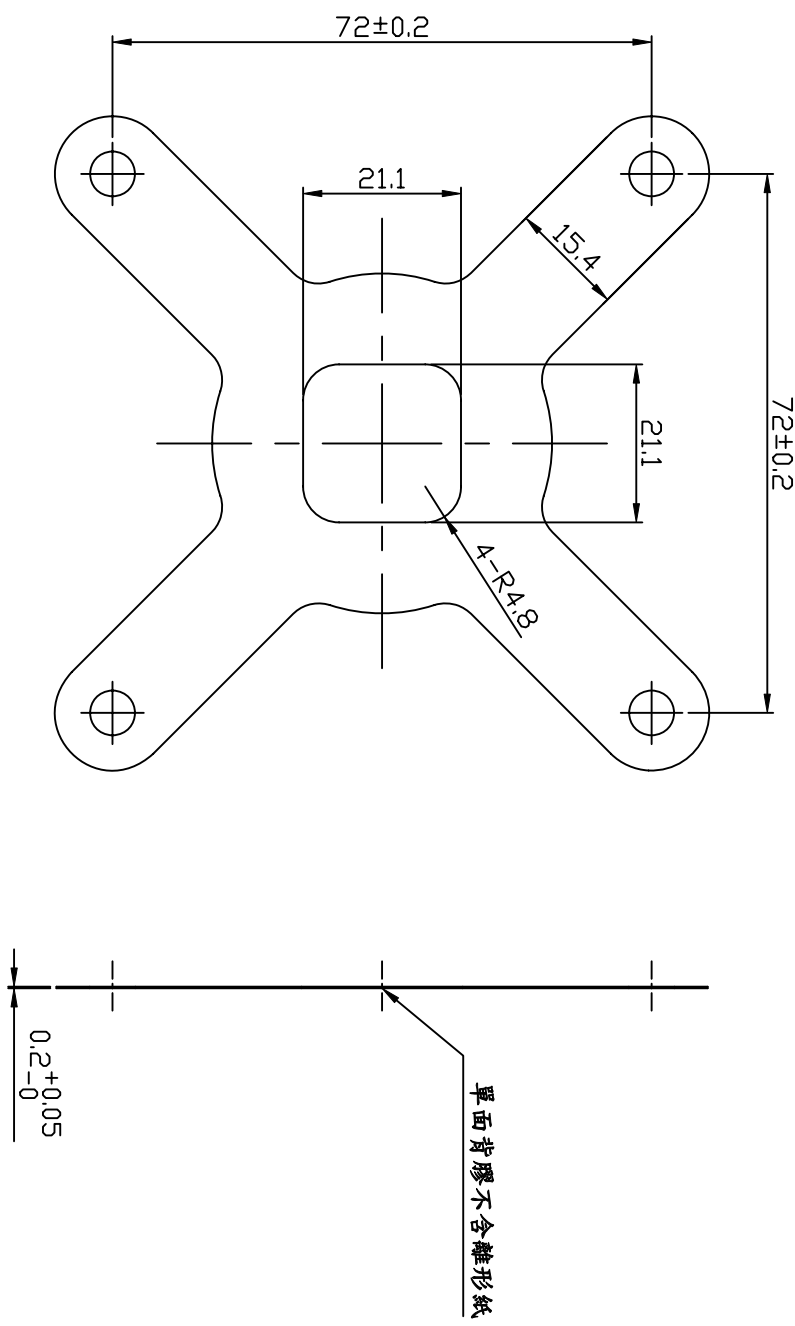

RANGE	TOL #																	
	M1	M2	S1	S2	P1	P2	C	URS										
0~6	0.05	0.10	0.15	0.20	0.05	0.10	0.50	0.20										
6~30	0.10	0.20	0.15	0.25	0.10	0.15	1.00	0.25										
30~120	0.15	0.25	0.20	0.30	0.20	0.40	2.00	0.45										
120~300	0.15	0.30	0.25	0.45	0.40	0.80	3.00	0.80										
300~600	0.20	0.50	0.40	0.60	0.60	1.20	3.00	1.20										
600~1200	0.30	0.80	0.70	1.10	0.80	1.50	4.00	1.50										

MODEL	NAME	FINISH	MATERIAL
JAT050-2	Back-rubber	---	#467MP+黑色PET
DRN	Fanny	12/11	2006
DSN	John	12/11	2006
CKD	Richard	12/11	2006
APPD	Auric	12/11	2006

CHIA CHERNE INDUSTRY CO.,LTD

REV.	DESCRIPTION	SIGN	DATE
--			

DRAWING NO.	JAT050-2
DIM IN	mm
SHEET	1
DD NOT SCALE DWG	DF 1



Laminating Adhesives Data Page

FOD # 0330

3M™ 467MP Roll Laminating Adhesive 468MP Roll Laminating Adhesive

Product Construction

	<u>Adhesive</u>	<u>Liner</u>
467MP	2.0 mils (50 microns) #200MP “Hi-Performance” Acrylic Adhesive	4.0 mils (100 microns) 58# Tan Polycoated Kraft Paper
468MP	5.0 mils (125 microns) #200MP “Hi-Performance” Acrylic Adhesive	4.0 mils (100 microns) 58# Tan Polycoated Kraft Paper

Features

- High performance solvent-free acrylic adhesive for exceptional environmental resistance and enhanced bond strength.
- Superior adhesive smoothness for improved clarity and reduced telegraphing through thin plastic facestocks.
- High cohesive strength for resistance to edge lifting and slippage.
- 2.0 mil 467MP is ideal for application to relatively smooth surfaces.
- 5.0 mil 468MP is ideal for application to a variety of rough or textured surfaces.
- Moisture stable liner resists curling or wrinkling in high humidity.
- 200MP Hi-Performance adhesive is initially repositionable, then builds to high ultimate bond strength.

Applications

- Long term bonding of nameplates and decorative trim to metal and high surface energy plastics in the automotive, appliance and electronic markets.
- Excellent adhesive for bonding metal and plastic nameplates in the aerospace, instrumentation and medical markets.
- Used for lamination to back printed polycarbonate or polyester graphic overlay materials in the automotive, electronics and membrane switch markets.
- Used for lamination of wood veneers and plastic laminates to cabinetry and furniture.
- Used in the assembly of membrane switches, including spacers for circuit separation graphic overlay for switch display and bonding the complete switch to the application surface.

Physical Properties

(Typical values – not for specification use)

ASTM D-3330 (modified)
90 degree peel, 12"/min.
(305 mm/min) 2 mil
aluminum

	Product	20 Min. Dwell	
		Oz./In. N/100 mm	
- Metal (Stainless Steel)	467MP	44	48
	468MP	59	64
- High Surface Energy Plastic (ABS)	467MP	40	44
	468MP	52	57

3M Test (90 degree peel,
12"/min. 305 mm/min.)
2 mil aluminum to
various surfaces

	Product	72 Hr. Dwell		Ultimate Bond	
		Oz./In. N/100 mm		Oz./In. N/100 mm	
- Metal (Stainless Steel)	467MP	82	90	113	124
	468MP	109	119	178	194
- High Surface Energy Plastic (ABS)	467MP	47	51	43	47
	468MP	61	67	58	63
- Low Surface Energy Plastic (Polypropylene)	Not Recommended				

Environmental Performance

The properties defined are based on the attachment of impervious faceplate materials (such as aluminum) to an aluminum test surface.

Bond Build-up:	The bond strength of #200MP "Hi-Performance" Acrylic Adhesive increases as a function of time and temperature.
Humidity Resistance:	High humidity has a minimal effect on adhesive performance. Bond strengths are generally higher after exposure for 7 days at 90 degrees F (32 degrees C) and 90% relative humidity.
U.V. Resistance:	When properly applied, nameplates and decorative trim parts are not adversely affected by outdoor exposure.
Water Resistance:	Immersion in water has no appreciable effect on the bond strength. After 100 hours in room temperature water the bond actually shows an increase in strength.
Temperature Cycling Resistance:	Bond strength generally increases after cycling four times through: 4 hours at 158 degrees F (70 degrees C) 4 hours at -20 degrees F (-29 degrees C) 16 hours at room temperature
Chemical Resistance:	When properly applied, nameplate and decorative trim parts will hold securely after exposure to numerous chemicals including gasoline, oil, "Freon" TF, sodium chloride solution, mild acids and alkalis.
Low Service Temp:	-40 degrees F (-40 degrees C).
Heat Resistance:	The #200MP "Hi-Performance" adhesive is usable for short periods (minutes, hours) at temperatures up to 400 degrees F (204 degrees C) and for intermittent longer periods of time (days, weeks) up to 300 degrees F (149 degrees C).
Shelf Life:	Product retains its performance and properties for two years from date of manufacture if properly stored at room temperature conditions of 72 degrees F (22 degrees C) and 50% R.H. Storage in plastic bag is recommended.

Processing

Die-cutting:	Excellent die-cuttability. For easier processing lubricate dies with Laminoleum vanishing oil available from Metal Lubricants (708-333-8900).
Roll Laminating:	Excellent processability. A combination of metal and rubber rollers with moderate pressure is recommended.

Special Considerations/Application Tips

For maximum bond strength the surface should be thoroughly cleaned and dried. Typical cleaning solvents are heptane or isopropyl alcohol. Consult solvent manufacturer's Material Safety Data Sheet for proper handling and storage instructions.

Bond strength can also be improved with firm application pressure and moderate heat causing the adhesive to develop intimate contact with the bonding surface.

Ideal adhesive application temperature range is 70 degrees F to 100 degrees F (21 degrees C to 38 degrees C). Application is not recommended if surface temperature is below 50 degrees F (10 degrees C) because the adhesive becomes too firm to adhere readily. Once properly applied, low temperature holding is satisfactory. For more specific information contact our Customer Service and Sales Support "hot line" at 1-800-223-7427.

2/15/96

Terms and Conditions of Sale for products sold by 3M Identification and Converter Systems Division can be found in the ICSD Price Book and in other appropriate schedules.

Technical Data: All physical properties, statements, and recommendations are either based on tests we believe to be reliable or our experience, but they are not guaranteed. 3M recommends each user determine the suitability of the products for the intended use.

Warranty and Limited Remedy: THE FOLLOWING WARRANTY IS MADE IN LIEU OF ALL OTHER WARRANTIES, EXPRESSED OR IMPLIED, INCLUDING, BUT NOT LIMITED TO, THE IMPLIED WARRANTY OF MERCHANTABILITY, THE IMPLIED WARRANTY OF FITNESS FOR A PARTICULAR PURPOSE AND ANY IMPLIED WARRANTY ARISING OUT OF A COURSE OF DEALING, A CUSTOM OR USAGE OF TRADE: 3M warrants its product will be free from all defects.

If a product is proved to be defective, then the exclusive remedy 3M's and seller's sole obligation shall be, at 3M's option, to replace the quantity of the product which is proved to be defective or to refund the purchase price.

Limitation of Liability: 3M and seller shall not be liable for direct, indirect, special, incidental or consequential damages based breach of warranty, breach of contract, negligence, strict liability or any other legal theory.

The foregoing Warranty and Limited Remedy and Limitation of Liability may be changed only by a written agreement signed by authorized officers of 3M and seller.

Scotch, ScotchMark, ScotchCap, and Stamark are trademarks of 3M.



Identification and Converter Systems Division

3M Center, Building 220-7W-03
St. Paul, MN 55144-1000
USA
1 800 223 7427
1 800 258 7511 FAX
e-mail idconvert@mmm.com

3M Canada Inc.

PO Box 5757
London, Ontario
Canada N6A 4T1
1 800 265 1840
519 452 6090 FAX

©3M 1996

3M Mexico, S.A. de C.V.

Apartado Postal 14-139
Mexico, D.F. 07070
Mexico
52 5 728 2289
52 5 728 2299 FAX

3M Puerto Rico, Inc.

Puerto Rico Industrial Park
PO Box 100
Carolina, PR 00986-0100
809 750 3000
809 750 3035 FAX

Test Report

3M TAIWAN LTD.
66, 800 LANE, CHUNG-SHAN SOUTH ROAD, YANG-MEI,
TAOYUAN, TAIWAN, R. O. C.

Report No. : CE/2005/94442A
Date : 2005/09/28
Page : 1 of 18

The following merchandise was (were) submitted and identified by the client as :

Type of Product : 3M TAPE PRODUCTS WITH 200MP ADHESIVE
Style/Item No : 467MP, 468MP, 7952MP, 7955MP, 9667MP, 9668MP,
9492MP, 9495MP, 7953MP, 7945MP, 7956MP, 7957MP,
7959MP, 7961MP
Sample Received : 2004/12/31 & 2005/03/24 & 2005/08/31 & 2005/09/21
Testing Date : 2004/12/31 TO 2005/01/07 & 2005/03/24 TO
2005/03/31 & 2005/08/31 TO 2005/09/08 &
2005/09/21 TO 2005/09/28

=====
Test Result : - Please see the next page -

* This report is combined with report of CE/2005/87179A *

Daniel Yeh, M.R. / Operation Manager
Signed for and on behalf of
SGS TAIWAN LTD.

Test Report

3M TAIWAN LTD.
66, 800 LANE, CHUNG-SHAN SOUTH ROAD, YANG-MEI,
TAOYUAN, TAIWAN, R. O. C.

Report No. : CE/2005/94442A
Date : 2005/09/28
Page : 2 of 18

Test Result

PART NAME NO.1 : TRANSPARENT DOUBLE COATED TAPE
(CE/2005/87179A & CE/2005/94442) (PLEASE
REFER TO THE PHOTO ATTACHED)

Test Item (s):	Unit	Method	MDL	Result
				No.1
Asbestos				
Anthrophyllite(CAS NO.017068-78-9)	**	As per NIOSH 9000 method. Analysis was performed by XRD.	-	Negative
Crocodolite(CAS NO.012001-28-4)	**	As per NIOSH 9000 method. Analysis was performed by XRD.	-	Negative
Amosite(CAS NO.012172-73-5)	**	As per NIOSH 9000 method. Analysis was performed by XRD.	-	Negative
Tremolite(CAS NO.014567-73-8)	**	As per NIOSH 9000 method. Analysis was performed by XRD.	-	Negative
Chrysotile(CAS NO.012001-29-5)	**	As per NIOSH 9000 method. Analysis was performed by XRD.	-	Negative
Actinolite(CAS NO.013768-00-8)	**	As per NIOSH 9000 method. Analysis was performed by XRD.	-	Negative

Test Item (s):	Unit	Method	MDL	Result
				No.1
AZO		As per LMBG 8202-2		
4-AMINODIPHENYL (CAS NO.92-67-1)	ppm	Analysis was performed by GC/MS.	3	N.D.
BENZIDINE (CAS NO.92-87-5)	ppm	Analysis was performed by GC/MS.	3	N.D.
4-CHLORO-O-TOLUIDINE (CAS NO.95-69-2)	ppm	Analysis was performed by GC/MS.	3	N.D.
2-NAPHTHYLAMINE (CAS NO.91-59-8)	ppm	Analysis was performed by GC/MS.	3	N.D.

Test Report

3M TAIWAN LTD.
66, 800 LANE, CHUNG-SHAN SOUTH ROAD, YANG-MEI,
TAOYUAN, TAIWAN, R. O. C.

Report No. : CE/2005/94442A
Date : 2005/09/28
Page : 3 of 18

Test Item (s):	Unit	Method	MDL	Result
				No.1
O-AMINOAZOTOLUENE (CAS NO.97-56-3)	ppm	Analysis was performed by GC/MS.	3	N.D.
2-AMINO-4-NITROTOLUENE (CAS NO.99-55-8)	ppm	Analysis was performed by GC/MS.	3	N.D.
P-CHLOROANILINE (CAS NO.106-47-8)	ppm	Analysis was performed by GC/MS.	3	N.D.
2,4-DIAMINOANISOLE (CAS NO.615-05-4)	ppm	Analysis was performed by GC/MS.	3	N.D.
4,4- DIAMINODIPHENYLMETHA NE (CAS NO.101-77-9)	ppm	Analysis was performed by GC/MS.	3	N.D.
3,3-DICHLOROBENZIDINE (CAS NO.91-94-1)	ppm	Analysis was performed by GC/MS.	3	N.D.
3,3-DIMETHOXYBENZIDINE (CAS NO.119-90-4)	ppm	Analysis was performed by GC/MS.	3	N.D.
3,3-DIMETHYLBENZIDINE (CAS NO.119-93-7)	ppm	Analysis was performed by GC/MS.	3	N.D.
3,3-DIMETHYL-4,4- DIAMINODIPHENYLMETHA NE (CAS NO.838-88-0)	ppm	Analysis was performed by GC/MS.	3	N.D.
P-CRESIDINE(2-METHOXY- 5-METHYLANILINE) (CAS NO.120-71-8)	ppm	Analysis was performed by GC/MS.	3	N.D.
4,4-METHYLENE-BIS-(2- CHLORANILINE) (CAS NO.101-14-4)	ppm	Analysis was performed by GC/MS.	3	N.D.
4,4-OXYDIANILINE (CAS NO.101-80-4)	ppm	Analysis was performed by GC/MS.	3	N.D.
4,4-THIODIANILINE (CAS NO.139-65-1)	ppm	Analysis was performed by GC/MS.	3	N.D.
O-TOLUIDINE (CAS NO.95- 53-4)	ppm	Analysis was performed by GC/MS.	3	N.D.

Test Report

3M TAIWAN LTD.
66, 800 LANE, CHUNG-SHAN SOUTH ROAD, YANG-MEI,
TAOYUAN, TAIWAN, R. O. C.

Report No. : CE/2005/94442A
Date : 2005/09/28
Page : 4 of 18

Test Item (s):	Unit	Method	MDL	Result
				No.1
2,4-TOLUYLENDIAMINE (CAS NO.95-80-7)	ppm	Analysis was performed by GC/MS.	3	N.D.
2,4,5-TRIMETHYLANILINE (CAS NO.137-17-7)	ppm	Analysis was performed by GC/MS.	3	N.D.
O-ANISIDINE (CAS NO.90- 04-0)	ppm	Analysis was performed by GC/MS.	3	N.D.
P-AMINOAZOBENZENE (CAS NO.60-09-3)	ppm	Analysis was performed by GC/MS.	3	N.D.

Test Item (s):	Unit	Method	MDL	Result
				No.1
CFC's(Chlorofluorocarbons)		With reference to US EPA 8260.		
Group I				
Chlorofluorocarbon-11(CAS No:000075-69-4)	ppm	Analysis was performed by GC/MS.(CFC's(Chlorofluoro carbons))	1	N.D.
Chlorofluorocarbon-12(CAS No:000075-71-8)	ppm	Analysis was performed by GC/MS. [CFC's (Chlorofluorocarbons)]	1	N.D.
Chlorofluorocarbon-113(CAS No:000076-13-1)	ppm	Analysis was performed by GC/MS. [CFC's (Chlorofluorocarbons)]	1	N.D.
Chlorofluorocarbon-114(CAS No:000076-14-2)	ppm	Analysis was performed by GC/MS. [CFC's (Chlorofluorocarbons)]	1	N.D.
Chlorofluorocarbon-115(CAS No:000076-15-3)	ppm	Analysis was performed by GC/MS. [CFC's (Chlorofluorocarbons)]	1	N.D.
Group III				
Chlorofluorocarbon-13(CAS No:000075-72-9)	ppm	Analysis was performed by GC/MS. [CFC's (Chlorofluorocarbons)]	1	N.D.
Chlorofluorocarbon-111(CAS No:000354-56-3)	ppm	Analysis was performed by GC/MS. [CFC's (Chlorofluorocarbons)]	1	N.D.

Test Report

3M TAIWAN LTD.
66, 800 LANE, CHUNG-SHAN SOUTH ROAD, YANG-MEI,
TAOYUAN, TAIWAN, R. O. C.

Report No. : CE/2005/94442A
Date : 2005/09/28
Page : 5 of 18

Test Item (s):	Unit	Method	MDL	Result
				No.1
Chlorofluorocarbon-112(CAS No:000076-12-0)	ppm	Analysis was performed by GC/MS. [CFC's (Chlorofluorocarbons)]	1	N.D.
Chlorofluorocarbon-211(CAS No:135401-87-5)	ppm	Analysis was performed by GC/MS. [CFC's (Chlorofluorocarbons)]	1	N.D.
Chlorofluorocarbon-212(CAS No:076564-99-3)	ppm	Analysis was performed by GC/MS. [CFC's (Chlorofluorocarbons)]	1	N.D.
Chlorofluorocarbon-213(CAS No:060285-54-3)	ppm	Analysis was performed by GC/MS. [CFC's (Chlorofluorocarbons)]	1	N.D.
Chlorofluorocarbon-214(CAS No:002268-46-4)	ppm	Analysis was performed by GC/MS. [CFC's (Chlorofluorocarbons)]	1	N.D.
Chlorofluorocarbon-215(CAS No:000076-17-5)	ppm	Analysis was performed by GC/MS. [CFC's (Chlorofluorocarbons)]	1	N.D.
Chlorofluorocarbon-216(CAS No:001652-80-8)	ppm	Analysis was performed by GC/MS. [CFC's (Chlorofluorocarbons)]	1	N.D.
Chlorofluorocarbon-217(CAS No:000422-86-6)	ppm	Analysis was performed by GC/MS. [CFC's (Chlorofluorocarbons)]	1	N.D.

Test Item (s):	Unit	Method	MDL	Result
				No.1
Chlorinated Paraffin (C10~C13) (CAS NO:010871-26-2)	%	Analysis was performed by GC/MS.	0.01	N.D.

Test Item (s):	Unit	Method	MDL	Result
				No.1
Formaldehyde(CAS No:000050-00-0)	ppm	With reference to DIN 53315 & USEPA 8315A. Analysis was performed by HPLC/DAD/MS	0.2	N.D.

Test Report

3M TAIWAN LTD.
66, 800 LANE, CHUNG-SHAN SOUTH ROAD, YANG-MEI,
TAOYUAN, TAIWAN, R. O. C.

Report No. : CE/2005/94442A
Date : 2005/09/28
Page : 6 of 18

Test Item (s):	Unit	Method	MDL	Result
				No.1
HCFC's(Hydrogenated chlorofluorocarbons)		With reference to US EPA 8260.		
Hydrochlorofluorocarbon-21(CAS No.:000075-43-4)	ppm	Analysis was performed by GC/MS. [HCFC's (Hydrogenated chlorofluorocarbons)]	1	N.D.
Hydrochlorofluorocarbon-22(CAS No.:000075-45-6)	ppm	Analysis was performed by GC/MS. [HCFC's (Hydrogenated chlorofluorocarbons)]	1	N.D.
Hydrochlorofluorocarbon-31(CAS No.:000593-70-4)	ppm	Analysis was performed by GC/MS. [HCFC's (Hydrogenated chlorofluorocarbons)]	1	N.D.
Hydrochlorofluorocarbon-121(CAS No.:000354-14-3)	ppm	Analysis was performed by GC/MS. [HCFC's (Hydrogenated chlorofluorocarbons)]	1	N.D.
Hydrochlorofluorocarbon-122(CAS No.:000354-21-2)	ppm	Analysis was performed by GC/MS. [HCFC's (Hydrogenated chlorofluorocarbons)]	1	N.D.
Hydrochlorofluorocarbon-123(CAS No.:000306-83-1)	ppm	Analysis was performed by GC/MS. [HCFC's (Hydrogenated chlorofluorocarbons)]	1	N.D.
Hydrochlorofluorocarbon-124(CAS No.:002837-89-0)	ppm	Analysis was performed by GC/MS. [HCFC's (Hydrogenated chlorofluorocarbons)]	1	N.D.
Hydrochlorofluorocarbon-131(CAS No.:000359-28-4)	ppm	Analysis was performed by GC/MS. [HCFC's (Hydrogenated chlorofluorocarbons)]	1	N.D.

Test Report

3M TAIWAN LTD.
66, 800 LANE, CHUNG-SHAN SOUTH ROAD, YANG-MEI,
TAOYUAN, TAIWAN, R. O. C.

Report No. : CE/2005/94442A
Date : 2005/09/28
Page : 7 of 18

Test Item (s):	Unit	Method	MDL	Result
				No.1
Hydrochlorofluorocarbon-131b(CAS No.:000471-43-2)	ppm	Analysis was performed by GC/MS. [HCFC's (Hydrogenated chlorofluorocarbons)]	1	N.D.
Hydrochlorofluorocarbon-133a(CAS No.:000075-88-7)	ppm	Analysis was performed by GC/MS. [HCFC's (Hydrogenated chlorofluorocarbons)]	1	N.D.
Hydrochlorofluorocarbon-141b(CAS No.:001717-00-6)	ppm	Analysis was performed by GC/MS. [HCFC's (Hydrogenated chlorofluorocarbons)]	1	N.D.
Hydrochlorofluorocarbon-221	ppm	Analysis was performed by GC/MS. [HCFC's (Hydrogenated chlorofluorocarbons)]	1	N.D.
Hydrochlorofluorocarbon-222(CAS No.:000422-30-0)	ppm	Analysis was performed by GC/MS. [HCFC's (Hydrogenated chlorofluorocarbons)]	1	N.D.
Hydrochlorofluorocarbon-223	ppm	Analysis was performed by GC/MS. [HCFC's (Hydrogenated chlorofluorocarbons)]	1	N.D.
Hydrochlorofluorocarbon-224	ppm	Analysis was performed by GC/MS. [HCFC's (Hydrogenated chlorofluorocarbons)]	1	N.D.
Hydrochlorofluorocarbon-225ca(CAS No.:000422-56-0)	ppm	Analysis was performed by GC/MS. [HCFC's (Hydrogenated chlorofluorocarbons)]	1	N.D.
Hydrochlorofluorocarbon-225cb(CAS No.:000507-55-1)	ppm	Analysis was performed by GC/MS. [HCFC's (Hydrogenated chlorofluorocarbons)]	1	N.D.

Test Report

3M TAIWAN LTD.
66, 800 LANE, CHUNG-SHAN SOUTH ROAD, YANG-MEI,
TAOYUAN, TAIWAN, R. O. C.

Report No. : CE/2005/94442A
Date : 2005/09/28
Page : 8 of 18

Test Item (s):	Unit	Method	MDL	Result
				No.1
Hydrochlorofluorocarbon-226(CAS No.:000431-87-8)	ppm	Analysis was performed by GC/MS. [HCFC's (Hydrogenated chlorofluorocarbons)]	1	N.D.
Hydrochlorofluorocarbon-231	ppm	Analysis was performed by GC/MS. [HCFC's (Hydrogenated chlorofluorocarbons)]	1	N.D.
Hydrochlorofluorocarbon-232	ppm	Analysis was performed by GC/MS. [HCFC's (Hydrogenated chlorofluorocarbons)]	1	N.D.
Hydrochlorofluorocarbon-233	ppm	Analysis was performed by GC/MS. [HCFC's (Hydrogenated chlorofluorocarbons)]	1	N.D.
Hydrochlorofluorocarbon-234	ppm	Analysis was performed by GC/MS. [HCFC's (Hydrogenated chlorofluorocarbons)]	1	N.D.
Hydrochlorofluorocarbon-235(CAS No.:013838-16-9)	ppm	Analysis was performed by GC/MS. [HCFC's (Hydrogenated chlorofluorocarbons)]	1	N.D.
Hydrochlorofluorocarbon-241	ppm	Analysis was performed by GC/MS. [HCFC's (Hydrogenated chlorofluorocarbons)]	1	N.D.
Hydrochlorofluorocarbon-242	ppm	Analysis was performed by GC/MS. [HCFC's (Hydrogenated chlorofluorocarbons)]	1	N.D.
Hydrochlorofluorocarbon-243(CAS No.:000338-75-0)	ppm	Analysis was performed by GC/MS. [HCFC's (Hydrogenated chlorofluorocarbons)]	1	N.D.

Test Report

3M TAIWAN LTD.
66, 800 LANE, CHUNG-SHAN SOUTH ROAD, YANG-MEI,
TAOYUAN, TAIWAN, R. O. C.

Report No. : CE/2005/94442A
Date : 2005/09/28
Page : 9 of 18

Test Item (s):	Unit	Method	MDL	Result
				No.1
Hydrochlorofluorocarbon-244	ppm	Analysis was performed by GC/MS. [HCFC's (Hydrogenated chlorofluorocarbons)]	1	N.D.
Hydrochlorofluorocarbon-251	ppm	Analysis was performed by GC/MS. [HCFC's (Hydrogenated chlorofluorocarbons)]	1	N.D.
Hydrochlorofluorocarbon-252	ppm	Analysis was performed by GC/MS. [HCFC's (Hydrogenated chlorofluorocarbons)]	1	N.D.
Hydrochlorofluorocarbon-253(CAS No.:000354-06-1)	ppm	Analysis was performed by GC/MS. [HCFC's (Hydrogenated chlorofluorocarbons)]	1	N.D.
Hydrochlorofluorocarbon-261(CAS No.:000420-97-3)	ppm	Analysis was performed by GC/MS. [HCFC's (Hydrogenated chlorofluorocarbons)]	1	N.D.
Hydrochlorofluorocarbon-262(CAS No.:000420-97-3)	ppm	Analysis was performed by GC/MS. [HCFC's (Hydrogenated chlorofluorocarbons)]	1	N.D.
Hydrochlorofluorocarbon-271	ppm	Analysis was performed by GC/MS. [HCFC's (Hydrogenated chlorofluorocarbons)]	1	N.D.

Test Item (s):	Unit	Method	MDL	Result
				No.1
Mirex(CAS NO:002385-85-5)	ppm	Analysis was performed by GC/MS.	4	N.D.

Test Report

3M TAIWAN LTD.
66, 800 LANE, CHUNG-SHAN SOUTH ROAD, YANG-MEI,
TAOYUAN, TAIWAN, R. O. C.

Report No. : CE/2005/94442A
Date : 2005/09/28
Page : 10 of 18

Test Item (s):	Unit	Method	MDL	Result
				No.1
Organic-tin compounds				
Triphenyl Tin(TPT)(CAS NO:000668-34-8)	ppm	With reference to 83/677/EEC & DIN 38407. Analysis was performed by GC/FPD.	0.03	N.D.
Tributyl Tin(TBT)	ppm	With reference to 83/677/EEC & DIN 38407. Analysis was performed by GC/FPD.	0.03	N.D.

Test Item (s):	Unit	Method	MDL	Result
				No.1
PCBs(Polychlorinated Biphenyls)(CAS NO:001336-36-3)	ppm	With reference to USEPA 8082A. Analysis was performed by GC/ECD/MS.	0.5	N.D.

Test Item (s):	Unit	Method	MDL	Result
				No.1
Polychlorinated Naphthalene	ppm	With reference to USEPA 8081B. Analysis was performed by GC/MS.	5	N.D.

Test Item (s):	Unit	Method	MDL	Result
				No.1
1,1,1-trichloroethane	ppm	With reference to US EPA 8260. Analysis was performed by GC/MS.	1	N.D.

Test Item (s):	Unit	Method	MDL	Result
				No.1
Carbon tetrachloride	ppm	With reference to US EPA 8260. Analysis was performed by GC/MS/HEADSPACE.	1	N.D.

Test Report

3M TAIWAN LTD.
66, 800 LANE, CHUNG-SHAN SOUTH ROAD, YANG-MEI,
TAOYUAN, TAIWAN, R. O. C.

Report No. : CE/2005/94442A
Date : 2005/09/28
Page : 11 of 18

Test Item (s):	Unit	Method	MDL	Result
				No.1
Chromium VI (Cr+6)	ppm	As per US EPA 7196A and US EPA 3060A.	2	N.D.
Arsenic (As)	ppm	ICP-AES after as per US EPA 3050B or other acid digestion.	2	N.D.
Beryllium (Be)	ppm	ICP-AES after as per US EPA 3050B or other acid digestion.	2	N.D.
Cadmium (Cd)	ppm	ICP-AES after reference to EN 1122, method B:2001 or other acid digestion.	2	N.D.
Mercury (Hg)	ppm	ICP-AES after as per US EPA 3052 or other acid digestion.	2	N.D.
Nickel (Ni)	ppm	ICP-AES after as per US EPA 3050B or other acid digestion.	2	N.D.
Lead (Pb)	ppm	ICP-AES after reference to US EPA 3050B or other acid digestion.	2	N.D.
Antimony (Sb)	ppm	ICP-AES after as per US EPA 3050B or other acid digestion.	2	N.D.
Tellurium (Te)	ppm	ICP-AES after as per US EPA 3050B or other acid digestion.	2	N.D.

Test Item (s):	Unit	Method	MDL	Result
				No.1
PCTs(Polychlorinated Terphenyls)	ppm	Analysis was performed by GC/ECD/MS.	0.5	N.D.

Test Report

3M TAIWAN LTD.
66, 800 LANE, CHUNG-SHAN SOUTH ROAD, YANG-MEI,
TAOYUAN, TAIWAN, R. O. C.

Report No. : CE/2005/94442A
Date : 2005/09/28
Page : 12 of 18

Test Item (s):	Unit	Method	MDL	Result
				No.1
PVC free(CAS No:9002-86-2)	**	Analysis was performed by FTIR/ATR and Pyro-GC/MS.	-	Negative

Test Item (s):	Unit	Method	MDL	Result
				No.1
Halogen		As per EN14582 method B.		
Halogen-Chlorine (Cl)(CAS No:007782-50-5)	ppm	Filling the oxygen and absorb solution in the flask and take sample in the flask and burn it, the absorb solution was analyzed by IC method.	50	N.D.
Halogen-Fluorine (F)(CAS No:007782-41-4)	ppm	Filling the oxygen and absorb solution in the flask and take sample in the flask and burn it, the absorb solution was analyzed by IC method.	50	N.D.
Halogen-Bromine (Br)(CAS No:007726-95-6)	ppm	Filling the oxygen and absorb solution in the flask and take sample in the flask and burn it, the absorb solution was analyzed by IC method.	50	N.D.
Halogen-Iodine (I)(CAS No:007553-56-2)	ppm	Filling the oxygen and absorb solution in the flask and take sample in the flask and burn it, the absorb solution was analyzed by IC method.	50	N.D.

Test Item (s):	Unit	Method	MDL	Result
				No.1
PCP(Pentachlorophenol) (CAS No:004901-51-3)	ppm	With reference to US EPA 8270D. Analysis was performed by GC/MS.	1	N.D.

Test Report

3M TAIWAN LTD.
66, 800 LANE, CHUNG-SHAN SOUTH ROAD, YANG-MEI,
TAOYUAN, TAIWAN, R. O. C.

Report No. : CE/2005/94442A
Date : 2005/09/28
Page : 13 of 18

Test Item (s):	Unit	Method	MDL	Result
				No.1
Monobromobiphenyl	%	With reference to USEPA3540C or USEPA3550C. Analysis was performed by HPLC/DAD, LC/MS or GC/MS. (prohibited by 2002/95/EC (RoHS), 83/264/EEC, and 76/769/EEC)	0.0005	N.D.
Dibromobiphenyl	%		0.0005	N.D.
Tribromobiphenyl	%		0.0005	N.D.
Tetrabromobiphenyl	%		0.0005	N.D.
Pentabromobiphenyl	%		0.0005	N.D.
Hexabromobiphenyl	%		0.0005	N.D.
Heptabromobiphenyl	%		0.0005	N.D.
Octabromobiphenyl	%		0.0005	N.D.
Nonabromobiphenyl	%		0.0005	N.D.
Decabromobiphenyl	%		0.0005	N.D.
Total PBBs (Polybrominated biphenyls)/Sum of above	%		-	N.D.
Monobromobiphenyl ether	%	With reference to USEPA3540C or USEPA3550C. Analysis was performed by HPLC/DAD, LC/MS or GC/MS. (prohibited by 2002/95/EC (RoHS), 83/264/EEC, and 76/769/EEC)	0.0005	N.D.
Dibromobiphenyl ether	%		0.0005	N.D.
Tribromobiphenyl ether	%		0.0005	N.D.
Tetrabromobiphenyl ether	%		0.0005	N.D.
Pentabromobiphenyl ether	%		0.0005	N.D.
Hexabromobiphenyl ether	%		0.0005	N.D.
Heptabromobiphenyl ether	%		0.0005	N.D.
Octabromobiphenyl ether	%		0.0005	N.D.
Nonabromobiphenyl ether	%		0.0005	N.D.
Decabromobiphenyl ether	%		0.0005	N.D.
Total PBBEs(PBDEs) (Polybrominated biphenyl ethers)/Sum of above	%		-	N.D.

Test Report

3M TAIWAN LTD.
66, 800 LANE, CHUNG-SHAN SOUTH ROAD, YANG-MEI,
TAOYUAN, TAIWAN, R. O. C.

Report No. : CE/2005/94442A
Date : 2005/09/28
Page : 14 of 18

Test Item (s):	Unit	Method	MDL	Result
				No.1
Halon		With reference to US EPA 8260.		
Halon-1211	ppm	Analysis was performed by GC/MS. [CFC's (Chlorofluorocarbons)]	1	N.D.
Halon-1301	ppm	Analysis was performed by GC/MS. [CFC's (Chlorofluorocarbons)]	1	N.D.
Halon-2402	ppm	Analysis was performed by GC/MS. [CFC's (Chlorofluorocarbons)]	1	N.D.

NOTE: (1) N.D. = Not detected (<MDL)
(2) ppm = mg/kg
(3) MDL = Method Detection Limit
(4) " - " = No Regulation
(5) ** = Qualitative analysis (No Unit)
(6) Negative = Undetectable / Positive = Detectable

Test Report

3M TAIWAN LTD.
66, 800 LANE, CHUNG-SHAN SOUTH ROAD, YANG-MEI,
TAOYUAN, TAIWAN, R. O. C.

Report No. : CE/2005/94442A
Date : 2005/09/28
Page : 15 of 18

These samples were dissolved totally by pre-conditioning method according to below flow chart.

Flow Chart of Digestion for Plastic – EN1122 for Cd (without residue)

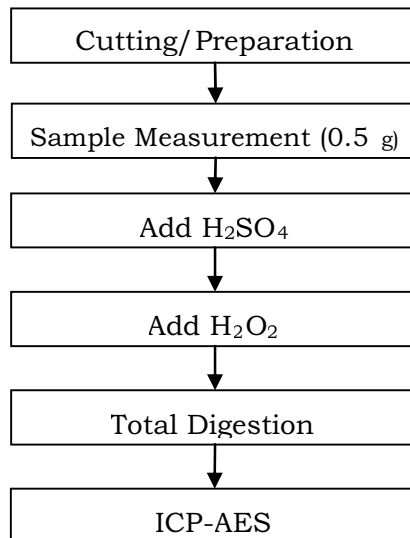

Test Report

3M TAIWAN LTD.
66, 800 LANE, CHUNG-SHAN SOUTH ROAD, YANG-MEI,
TAOYUAN, TAIWAN, R. O. C.

Report No. : CE/2005/94442A
Date : 2005/09/28
Page : 16 of 18

These samples were dissolved totally by pre-conditioning method according to below flow chart.

Flow Chart of Digestion for Plastic –Wet Decomposition for Pb (without residue)

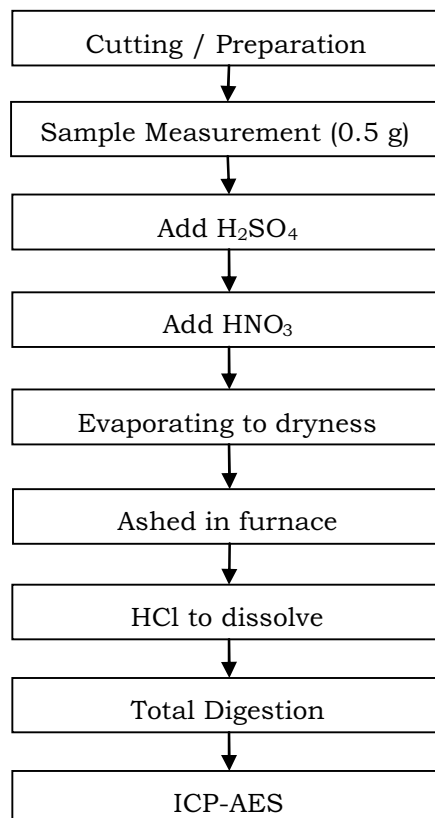

TEST REPORT

AMPLE DESCRIPTION

One (1) group of submitted samples said to be :

Sample Description : PET Film
TORAY

Item No. : S10, S105, S28, S56, T60, F10, F65, F60, H10, T99, X30, X43,
X44, X21, X20, X53, E20, E22, E60, E63, U34, U35, U426,
E60L, E60V, C21, F53, E6SL, E6SV, PPS#3000, PPS#5000,
PPS#3030, PPS#3A00, PPS#3030

Country of Original : Japan

Date sample received : Sep. 22, 2004

Date test started : Sep. 23, 2004

TEST CONDUCTED

As requested by the applicant, for details please refer to attached pages.

Prepared and checked by :
For Intertek Testing Services
Taiwan Limited

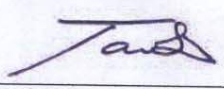

Jacob Lin
General Manager



This report shall not be
reproduced except in full,
without the written approval
of the laboratory.

TEST CONDUCTED

(A) Test result summary :

Testing item	Result (ppm)
	Submitted samples
Antimony (Sb) content / 銻含量	185 (#3)
Arsenic (As) content / 砷含量	ND (#1)
Beryllium (Be) content / 鈹含量	ND (#1)
Nickel (Ni) content / 鎳含量	ND (#2)
Cadmium (Cd) content / 鎘含量	ND (#1)
Lead (Pb) content / 鉛含量	ND (#1)
Mercury (Hg) content / 汞含量	ND (#1)
Tellurium (Te) content / 碲含量	ND (#2)
Chromium VI (Cr ⁶⁺) content / 六價鉻含量	ND (#1)
PBBs/PBDEs / 多溴聯苯/溴聯苯醚	ND (#1)
Polychlorinated biphenyls (PCBs) / 多氯聯苯	ND (#1)
Polychlorinated naphthalenes (PCNs) / 多氯化萘	ND (#1)
Polychlorinated terphenyls (PCTs) / 多氯三苯	ND (#1)
Chlorinated paraffins / 氯化石蠟 (C10-C13)	ND (#1)
Mirex (Perchlordecone) / 滅蟻靈	ND (#1)
TBBP-A-bis / 四溴雙酚-A-雙-(2,3-二溴丙醚)	ND (#1)
TBBA / 四溴化二苯酚	ND (#1)
Formaldehyde / 甲醛	ND (#1)
Polyvinyl chloride (PVC) / 聚氯乙烯和聚氯乙烯混合物	ND (#1)
Organic tin compounds (Tributyl tin compounds, triphenyl tin compounds) / 有機錫化合物 (三丁基錫化合物, 三苯基錫化合物)	ND (#1)
Asbestos / 石棉	ND (#1)
Azo dyes compounds / 偶氮化合物	ND (#1)
Polychlorinated phenols / 多氯酚	ND (#1)
CFCs/HCFs/Halon / 臭氣危害物質	ND (#2)
1, 1, 1 - Trichloroethane / 1, 1, 1, - 三氯乙烷	ND (#3)
Carbon Tetrachloride / 四氯化碳	ND (#3)

Remarks : ppm = Parts per million

ND = Not detected

#1 = The samples were tested on Sep. 30, 2004 report No. C414892 and the results were transferred to this report.

#2 = The samples were tested on Nov. 26, 2004 report No. C419530 and the results were transferred to this report.

#3 = The samples were tested on Apr. 25, 2005 report No. C506044 and the results were transferred to this report.

Intertek Testing Services Taiwan Ltd.

8F., No. 423, Ruiguang Rd., Neihu District, Taipei 114, Taiwan, R.O.C.

全國公證檢驗股份有限公司

114 台北市內湖區瑞光路 423 號 8 樓

Tel : (+886-2) 6602-2888 · 2797-8885 Fax : (+886-2) 6602-2410

TEST CONDUCTED

(B) Test method :

Testing item	Testing method	Reporting limit
Antimony (Sb) content 銻含量	With reference to USEPA 3052, by microwave digestion and determined by ICP-OES	2 ppm
Arsenic (As) content 砷含量	With reference to USEPA 3052, by microwave digestion and determined by ICP-OES	2 ppm
Beryllium (Be) content 鈹含量	With reference to USEPA 3052, by microwave digestion and determined by ICP-OES	2 ppm
Nickel (Ni) content 鎳含量	With reference to USEPA 3052, by microwave digestion and determined by ICP-OES	2 ppm
Cadmium (Cd) content 鎘含量	With reference to USEPA 3052, by microwave digestion and determined by ICP-OES	2 ppm
Lead (Pb) content 鉛含量	With reference to USEPA 3052, by microwave digestion and determined by ICP-OES	2 ppm
Mercury (Hg) content 汞含量	With reference to USEPA 3052, by microwave digestion and determined by ICP-OES	2 ppm
Tellurium (Te) content 碲含量	With reference to USEPA 3052, by microwave digestion and determined by ICP-OES	2 ppm
Chromium VI (Cr ⁶⁺) content 六價鉻含量	With reference to USEPA 3060A & 7196A, by alkaline digestion and determined by UV-Vis	1 ppm
PBBs/PBDEs 多溴聯苯/溴聯苯醚	With reference to USEPA 3540C, by solvent extraction and determined by GC-MSD	10 ppm
Polychlorinated biphenyls (PCBs) 多氯聯苯	With reference to USEPA 8082, by solvent extraction and determined by GC-ECD and GC-MSD	1 ppm
Polychlorinated naphthalenes (PCNs) 多氯化萘	With reference to USEPA 3540C, by solvent extraction and determined by GC-MSD	10 ppm
Polychlorinated terphenyls (PCTs) 多氯三苯	With reference to USEPA 3540C, by solvent extraction and determined by GC-MSD	10 ppm
Chlorinated paraffins (C10-C13) 氯化石蠟	With reference to USEPA 3540C, by solvent extraction and determined by GC-ECD and GC-MSD	10 ppm
Mirex (Perchlordecone) 滅蟻靈	With reference to USEPA 3540C, by solvent extraction and determined by GC-MSD	10 ppm
TBBP-A-bis 四溴雙酚-A-雙-(2,3-二溴丙醜)	With reference to USEPA 3540C, by solvent extraction and determined by HPLC-DAD	20 ppm
TBBA 四溴化二苯酚	As per DIN53313, by solvent extraction and determined by GC-ECD	20 ppm
Formaldehyde 甲醛	As per applicant's request with reference to DIN 53315 and determined by UV-Vis	5 ppm
Polyvinyl chloride (PVC) 聚氯乙烯和聚氯乙炔混合物	Beilstein's test (flame test) and FT-IR analysis	NA
Organic tin compounds (Tributyl tin compounds, triphenyl tin compounds) 有機錫化合物 (三丁基錫化合物, 三苯基錫化合物)	With reference to ISO 17353, by solvent extraction and determined by GC-MSD	1 ppm
Asbestos 石棉	FT-IR analysis	NA
Azo dyes compounds 偶氮化合物	As per ISO/TS 17234:2003, EN 14362-1:2003, EN 14362-2:2003, determined by GC-MSD	5 ppm
Polychlorinated phenols 多氯酚	As per DIN53313, by solvent extraction and determined by GC-ECD	1 ppm
CFCs/HCFCs/Halon 臭氣危害物質	By Tedlar bag collection and determined by GC-MSD	1 ppm
1, 1, 1 - Trichloroethane 1, 1, 1 - 三氯乙烷	With reference to USEPA 5035 & 8021B, by purge - and - trap extraction and determined by GC-PID/ELCD	0.016 ppm
Carbon Tetrachloride 四氯化碳	With reference to USEPA 5035 & 8021B, by purge - and - trap extraction and determined by GC-PID/ELCD	0.016 ppm

Remarks : NA = Not applicable

Reporting limit = Quantitation limit of analyte in sample solution

- END -

Intertek Testing Services Taiwan Ltd.

8F., No. 423, Ruiguang Rd., Neihu District, Taipei 114, Taiwan, R.O.C.

全國公證檢驗股份有限公司

114 台北市內湖區瑞光路 423 號 8 樓

Tel : (+886-2) 6602-2888 · 2797-8885 Fax : (+886-2) 6602-2410

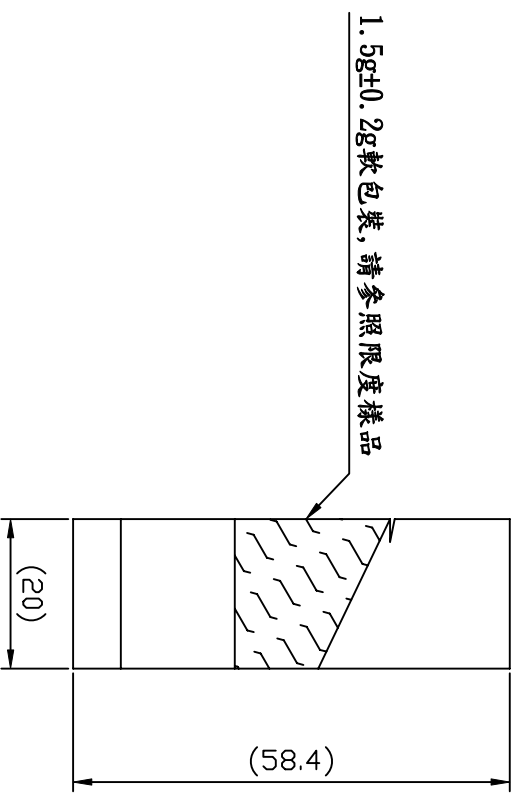

註:1. 導熱膏軟包封口不可破裂, 致導熱膏外漏.

MODEL	JAP001A		NAME	Thermal grease		REV.	—	DESCRIPTION	SIGN	DATE
DRN	Fanny	11/12 2003	MATERIAL	-----			DRAWING NO.	DIM INI mm	DD NOT SCALE	DWG
DSN	Angel	11/12 2003	FINISH							
CKD	Alex	11/12 2003	CHIA CHERNE INDUSTRY CO.,LTD							
APPD	Jason	11/12 2003								

JAP001A

SC102

HEAT-TRANSFER COMPOUND

SC102 heat-transfer compound is a grease like silicone material heavily filled with heat-conductive metal oxide.

SC102 heat-transfer compound is an improved product that can be used in touch with silicone JCR, where most of silicone heat-transfer compounds cause swelling of JCR. SC102 also shows excellent heat conductivity as well very little oil bleed. SC102 has rather high consistency and it is easy to handle and can be used in many appliances.

Properties of SC102

Properties	Unit	SC102
Consistency, penetration un-worked	--	300
Oil bleed (120°C / 24hrs)	%	0.00
Specific Gravity	--	2.45
Thermal Conductivity	Cal / cm • sec. C	0.0019
Arc Resistance	sec.	123
Dielectric Constant 60 Hz	--	4.6
1000 Hz	--	4.4
Dissipation Factor 60 HZ	--	0.034
1000 HZ	--	0.024
Volume Resistivity	ohm • cm	4.8×10^{14}
Dielectric Strength	kV / 2.5mm	22

Properties of SC102 in comparison with SH340

Properties	SC102	SH340 ^{a)}
Swelling of Silicone JCR ^{b)} Volume increase	0.9%	3.0%
Oil bleed on aluminum plate 120°C / 24hrs	None	observed
Appearance after heating 150°C / 24hrs	No change	No change

a) Conventional silicone heat-transfer compound

b) Cured silicone JCR (SH6101) was immersed in heat-transfer compound at 120°C for 120hrs.

Dow Corning Toray Silicone Co., Ltd.

AIG Bldg. 1-3, Marunouchi 1-chome, chiyoda-ku

Tokyo 100-0005, Japan

TEL: 03-3287 8300

IMPORTANT NOTICE :Dow Corning Toray Silicone neither represents nor tests this material for medical device applications or for pharmaceutical end-use.

NOT FOR HUMAN INJECTION !

This product is made to industrial grade standards. It is not intended for nor should it be used in medical device applications and pharmaceutical end-use.

Test Report

SIL-MORE INDUSTRIAL LTD.
16F, NO. 100, HSIN TEH ROAD, SAN CHUNG CITY,
TAIPEI COUNTY, TAIWAN, R. O. C.

Report No. : CE/2005/81840
Date : 2005/08/15
Page : 1 of 4

The following merchandise was (were) submitted and identified by the client as :

Type of Product : DOW CORNING TORAY SC102 HEAT SINK COMPOUND
Sample Received : 2005/08/09
Testing Date : 2005/08/09 TO 2005/08/15

=====
Test Result : - Please see the next page -

Daniel Yen, M.R. / Operation Manager
Signed for and on behalf of
SGS TAIWAN LTD.

Test Report

SIL-MORE INDUSTRIAL LTD.
16F, NO. 100, HSIN TEH ROAD, SAN CHUNG CITY,
TAIPEI COUNTY, TAIWAN, R. O. C.

Report No. : CE/2005/81840
Date : 2005/08/15
Page : 2 of 4

Test Result

PART NAME NO.1 : WHITE COLLOID (PLEASE REFER TO THE PHOTO ATTACHED)

Test Item (s):	Unit	Method	MDL	Result
				No. 1
Monobromobiphenyl	%	With reference to USEPA3540C or USEPA3550C. Analysis was performed by HPLC/DAD, LC/MS or GC/MS. (prohibited by 2002/95/EC (RoHS), 83/264/EEC, and 76/769/EEC)	0.0005	N.D.
Dibromobiphenyl	%		0.0005	N.D.
Tribromobiphenyl	%		0.0005	N.D.
Tetrabromobiphenyl	%		0.0005	N.D.
Pentabromobiphenyl	%		0.0005	N.D.
Hexabromobiphenyl	%		0.0005	N.D.
Heptabromobiphenyl	%		0.0005	N.D.
Octabromobiphenyl	%		0.0005	N.D.
Nonabromobiphenyl	%		0.0005	N.D.
Decabromobiphenyl	%		0.0005	N.D.
Total PBBs(Polybrominated biphenyls)/Sum of above	%	-	N.D.	
Monobromobiphenyl ether	%	With reference to USEPA3540C or USEPA3550C. Analysis was performed by HPLC/DAD, LC/MS or GC/MS. (prohibited by 2002/95/EC (RoHS), 83/264/EEC, and 76/769/EEC)	0.0005	N.D.
Dibromobiphenyl ether	%		0.0005	N.D.
Tribromobiphenyl ether	%		0.0005	N.D.
Tetrabromobiphenyl ether	%		0.0005	N.D.
Pentabromobiphenyl ether	%		0.0005	N.D.
Hexabromobiphenyl ether	%		0.0005	N.D.
Heptabromobiphenyl ether	%		0.0005	N.D.
Octabromobiphenyl ether	%		0.0005	N.D.
Nonabromobiphenyl ether	%		0.0005	N.D.
Decabromobiphenyl ether	%		0.0005	N.D.
Total PBBEs(PBDEs)(Polybrominated biphenyl ethers)/Sum of above	%	-	N.D.	

Test Report

SIL-MORE INDUSTRIAL LTD.
 16F, NO. 100, HSIN TEH ROAD, SAN CHUNG CITY,
 TAIPEI COUNTY, TAIWAN, R. O. C.

Report No. : CE/2005/81840
 Date : 2005/08/15
 Page : 3 of 4

Test Item (s):	Unit	Method	MDL	Result
				No.1
Chromium VI (Cr+6)	ppm	UV-VIS after reference to US EPA 3060A.	2	N.D.
Cadmium (Cd)	ppm	ICP-AES after reference to EN 1122, method B:2001 or other acid digestion.	2	N.D.
Mercury (Hg)	ppm	ICP-AES after reference to US EPA 3052 or other acid digestion.	2	N.D.
Lead (Pb)	ppm	ICP-AES after reference to US EPA 3050B or other acid digestion.	2	N.D.

NOTE: (1) N.D. = Not detected (<MDL)
 (2) ppm = mg/kg
 (3) MDL = Method Detection Limit
 (4) " - " = No Regulation

Test Report

SIL-MORE INDUSTRIAL LTD.
16F, NO. 100, HSIN TEH ROAD, SAN CHUNG CITY,
TAIPEI COUNTY, TAIWAN, R. O. C.

Report No. : CE/2005/72052
Date : 2005/07/18
Page : 1 of 4

The following merchandise was (were) submitted and identified by the client as :

Type of Product : PACKING MEMBRANE
Sample Received : 2005/07/11
Testing Date : 2005/07/11 TO 2005/07/18

=====
Test Result : - Please see the next page -

Daniel Yeh, M.R. / Operation Manager
Signed for and on behalf of
SGS TAIWAN LTD.

Test Report

SIL-MORE INDUSTRIAL LTD.
16F, NO. 100, HSIN TEH ROAD, SAN CHUNG CITY,
TAIPEI COUNTY, TAIWAN, R. O. C.

Report No. : CE/2005/72052
Date : 2005/07/18
Page : 2 of 4

Test Result

PART NAME NO.1 : MIXED TRANSPARENT PLASTIC MEMBRANE
&TRANSPARENT PLASTIC MEMB (PLEASE REFER
TO THE PHOTO ATTACHED)

Test Item (s):	Unit	Method	MDL	Result
				No. 1
Monobromobiphenyl	%	With reference to USEPA3540C or USEPA3550C. Analysis was performed by HPLC/DAD, LC/MS or GC/MS. (prohibited by 2002/95/EC (RoHS), 83/264/EEC, and 76/769/EEC)	0.0005	N.D.
Dibromobiphenyl	%		0.0005	N.D.
Tribromobiphenyl	%		0.0005	N.D.
Tetrabromobiphenyl	%		0.0005	N.D.
Pentabromobiphenyl	%		0.0005	N.D.
Hexabromobiphenyl	%		0.0005	N.D.
Heptabromobiphenyl	%		0.0005	N.D.
Octabromobiphenyl	%		0.0005	N.D.
Nonabromobiphenyl	%		0.0005	N.D.
Decabromobiphenyl	%		0.0005	N.D.
Total PBBs (Polybrominated biphenyls)/Sum of above	%		-	N.D.
Monobromobiphenyl ether	%	With reference to USEPA3540C or USEPA3550C. Analysis was performed by HPLC/DAD, LC/MS or GC/MS. (prohibited by 2002/95/EC (RoHS), 83/264/EEC, and 76/769/EEC)	0.0005	N.D.
Dibromobiphenyl ether	%		0.0005	N.D.
Tribromobiphenyl ether	%		0.0005	N.D.
Tetrabromobiphenyl ether	%		0.0005	N.D.
Pentabromobiphenyl ether	%		0.0005	N.D.
Hexabromobiphenyl ether	%		0.0005	N.D.
Heptabromobiphenyl ether	%		0.0005	N.D.
Octabromobiphenyl ether	%		0.0005	N.D.
Nonabromobiphenyl ether	%		0.0005	N.D.
Decabromobiphenyl ether	%		0.0005	N.D.
Total PBBEs(PBDEs) (Polybrominated biphenyl ethers)/Sum of above	%		-	N.D.

Test Report

SIL-MORE INDUSTRIAL LTD.
16F, NO. 100, HSIN TEH ROAD, SAN CHUNG CITY,
TAIPEI COUNTY, TAIWAN, R. O. C.

Report No. : CE/2005/72052
Date : 2005/07/18
Page : 3 of 4

Test Item (s):	Unit	Method	MDL	Result
				No.1
Chromium VI (Cr+6)	ppm	UV-VIS after reference to US EPA 3060A.	2	N.D.
Cadmium (Cd)	ppm	ICP-AES after reference to EN 1122, method B:2001 or other acid digestion.	2	N.D.
Mercury (Hg)	ppm	ICP-AES after reference to US EPA 3052 or other acid digestion.	2	N.D.
Lead (Pb)	ppm	ICP-AES after reference to US EPA 3050B or other acid digestion.	2	N.D.

NOTE: (1) N.D. = Not detected (<MDL)
(2) ppm = mg/kg
(3) MDL = Method Detection Limit
(4) " - " = No Regulation

Test Report

SIL-MORE INDUSTRIAL LTD.
16F, NO. 100, HSIN TEH ROAD, SAN CHUNG CITY,
TAIPEI COUNTY, TAIWAN, R. O. C.

Report No. : CE/2005/72052
Date : 2005/07/18
Page : 4 of 4



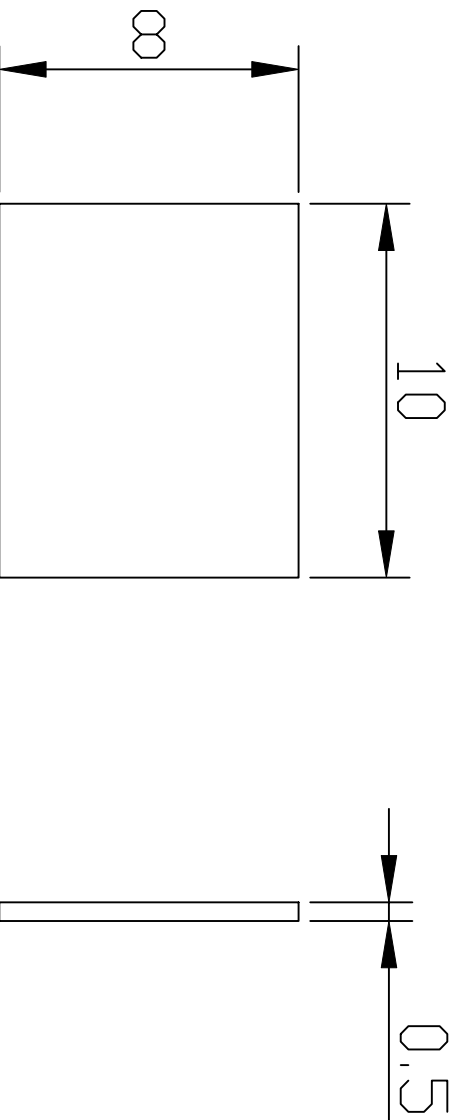

TOL #		MODEL		NAME		REV.		DESCRIPTION		SIGNATURE		DATE	
RANGE	URS	DRN	DSN	MATERIAL	FINISH	---				DD NOT SCALE	DWG		
0~6	0.20			PET	Transparent								
6~30	0.30	Fanny	Robert										
30~120	0.45	DRN	DSN										
120~300	0.80		CKD	Transparent									
300~600	1.20		APPD	CHIA CHERNE INDUSTRY CO.,LTD									
600~1200	1.50												
ANG.	TOL #												
	1°												

1 2 3 4

A B C D

A B C D



Test Report

NAN YA PLASTICS CORPORATION
NO. 2, CHUNGYANG INDUSTRIAL PARK, HSINKANG
VILLAGE, CHIAYI COUNTY, TAIWAN

Report No. : CY/2006/50558
Date : 2006/05/22
Page : 1 of 2

The following merchandise was (were) submitted and identified by the client as :

Type of Product : AMORPHOUS POLYESTER SHEET
Style/Item No : NAN YA A-PET SHEET
Manufacturer/Vendor : HSIN-KANG 2ND PLANT PLASTICS 2ND DIV
Sample Received : 2006/05/12
Testing Date : 2006/05/12 TO 2006/05/22

Test Result

PART NAME NO.1 : TRANSPARENT PLASTIC SHEET

PASS

Test Item (s):	Unit	Method	MDL	Result	Spec.
				No. 1	
EN 71 PART 3 Heavy metal content		As per EN 71 PART 3 : 1994 (A1 : 2000, AC:2000 and AC:2002) (EN 71 & BS 5665 are identical)			
Soluble Lead (Pb)	ppm	ICP-AES	5	< 5.0	90
Soluble Antimony (Sb)	ppm	ICP-AES	5	< 5.0	60
Soluble Arsenic (As)	ppm	ICP-AES	2.5	< 2.5	25
Soluble Barium (Ba)	ppm	ICP-AES	10	< 10.0	1000
Soluble Cadmium (Cd)	ppm	ICP-AES	5	< 5.0	75
Soluble Chromium (Cr)	ppm	ICP-AES	5	< 5.0	60
Soluble Mercury (Hg)	ppm	ICP-AES	5	< 5.0	60
Soluble Selenium (Se)	ppm	ICP-AES	5	< 5.0	500

NOTE: (1) N.D. = Not detected (<MDL)
(2) ppm = mg/kg
(3) MDL = Method Detection Limit

Daniel Yeh, M.R. / Operation Manager
Signed for and on behalf of
SGS TAIWAN LTD.

Any unauthorized alteration, forgery or falsification of the content or appearance of this report is unlawful and offenders may be prosecuted to the fullest extent of the law.
對本報告內容或外觀之任何未經授權之變更、偽造、竄改或濫用者，違犯者將會被依法追訴。

The content of this PDF file is in accordance with the original issued reports for reference only. This Test Report cannot be reproduced, except in full, without prior written permission of the Company



Test Report

NAN YA PLASTICS CORPORATION
NO. 2, CHUNGYANG INDUSTRIAL PARK, HSINKANG
VILLAGE, CHIAYI COUNTY, TAIWAN

Report No. : CY/2006/50558
Date : 2006/05/22
Page : 2 of 2



Any unauthorized alteration, forgery or falsification of the content or appearance of this report is unlawful and offenders may be prosecuted to the fullest extent of the law.
對本報告內容或外觀之任何未經授權之變更、偽造、篡改皆屬非法，違犯者將會被依法追訴。

The content of this PDF file is in accordance with the original issued reports for reference only. This Test Report cannot be reproduced, except in full, without prior written permission of the Company

SGS TAIWAN LIMITED

NO. 136-1, Wu Kung Road, WuKu Industrial Zone, Taipei county, Taiwan.
t(886-2) 22993939 f(886-2) 2299-3237 www.sgs.com.tw

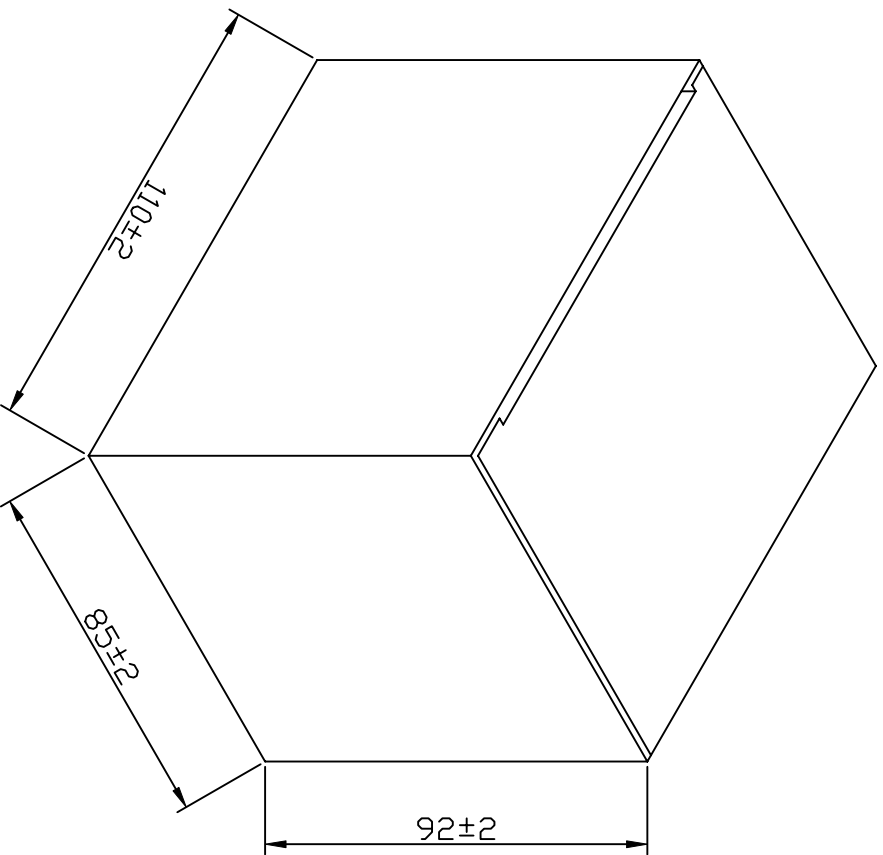

MODEL	PBJA88		NAME	Box		REV.	DESCRIPTION	SIGN	DATE	
DRN	Joyce	11/17 2004	---	MATERIAL	---	---				
DSN	John	11/17 2004	---	FINISH	---	---				
CKD	Angel	11/17 2004	CHIA CHERNE INDUSTRY CO.,LTD							
APPD	Kavin	11/17 2004	CHIA CHERNE INDUSTRY CO.,LTD							
							DIM IN	mm	DD NOT SCALE	DWG
						DRAWING NO.	SHEET	1	DF	1
						PBJA88				



Test Report

CHIU HO PAPER CO., LTD.
196, LANE 211, TUNG YUAN ROAD, HO MEI TOWN,
CHANGHUA COUNTY, TAIWAN 508

Report No. : CE/2004/C1590A
Date : 2004/12/16
Page : 1 of 2

The following merchandise was (were) submitted and identified by the client as :

Type of Product : KRAFT BOX
Sample Received : 2004/12/09
Testing Date : 2004/12/09 TO 2004/12/16

Test Result

PART NAME NO.1 : BROWN CARTON (PLEASE REFER TO THE PHOTO ATTACHED)

PASS

Test Item (s):	Unit	Method	MDL	Result				Spec.
				No.1				
94/62/EEC								
Chromium VI (Cr+6)	ppm	As per US EPA 7196A and US EPA 3060A.	2	N.D.				-
Cadmium (Cd)	ppm	ICP-AES after as per EN 1122, method B:2001 or other acid digestion.	2	N.D.				-
Lead (Pb)	ppm	ICP-AES after as per US EPA 3050B or other acid digestion.	2	N.D.				-
Mercury (Hg)	ppm	ICP-AES after as per US EPA 3052 or other acid digestion.	2	N.D.				-
Total Lead+Cadmium+Mercury+Chromium VI	ppm	Total Lead+Cadmium+Mercury+Chromium VI (94/62/EEC)	-	N.D.				100

- NOTE: (1) N.D. = Not detected (<MDL)
(2) ppm = mg/kg
(3) MDL = Method Detection Limit
(4) " - " = No Regulation

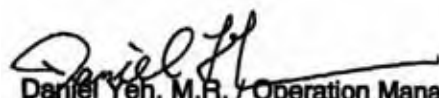
Daniel Yeh, M.R. / Operation Manager
Signed for and on behalf of
SGS TAIWAN LTD.



Test Report

AVATAACK CO., LTD.
NO. 21, SANMIN RD., FONGSHAN VILLAGE, HUKOU
TOWNSHIP, HSINCHU COUNTY 303, TAIWAN (R. O. C.)

Report No. : CE/2006/10501
Date : 2006/01/10
Page : 1 of 5

The following merchandise was (were) submitted and identified by the client as :

<u>Type of Product</u>	:	PAPER LABEL
<u>Style/Item No</u>	:	CLOH, CLOHL, CL9A, CL9B, CLA5, CLA8, CLW3, CLW3A, CLW3L, CLW3X
<u>Sample Received</u>	:	2006/01/03
<u>Testing Date</u>	:	2006/01/03 TO 2006/01/10

Conclusion

: The test results of Pb, Cd, Hg, Cr+6, PBB and PBDE for the submitted sample comply with the requirements of RoHS (2002/95/EC).

金同 KQ

 David Yen, M.R., Operations Manager
 Signed for and on behalf of
 SGS TAIWAN LTD.

SGS**Test Report**

AVATAACK CO., LTD.
NO. 21, SANMIN RD., FONGSHAN VILLAGE, HUKOU
TOWNSHIP, HSINCHU COUNTY 303, TAIWAN (R. O. C.)

Report No. : CE/2006/10501

Date : 2006/01/10

Page : 2 of 5

Test Result

PART NAME NO. 1 : YELLOW PAPER LABEL

PASS

Test Item (s):	Unit	Method	MDL	Result	Limit of ROHS
				No.1	
Monobromobiphenyl	%	With reference to USEPA3540C or USEPA3550C. Analysis was performed by HPLC/DAD, LC/MS or GC/MS. (prohibited by 2002/95/EC (RoHS), 83/264/EEC, and 76/769/EEC)	0.0005	N.D.	-
Dibromobiphenyl	%		0.0005	N.D.	-
Tribromobiphenyl	%		0.0005	N.D.	-
Tetrabromobiphenyl	%		0.0005	N.D.	-
Pentabromobiphenyl	%		0.0005	N.D.	-
Hexabromobiphenyl	%		0.0005	N.D.	-
Heptabromobiphenyl	%		0.0005	N.D.	-
Octabromobiphenyl	%		0.0005	N.D.	-
Nonabromobiphenyl	%		0.0005	N.D.	-
Decabromobiphenyl	%		0.0005	N.D.	-
Total PBBs (Polybrominated biphenyls)/Sum of above	%		-	N.D.	0.1
Monobromobiphenyl ether	%	With reference to USEPA3540C or USEPA3550C. Analysis was performed by HPLC/DAD, LC/MS or GC/MS. (prohibited by 2002/95/EC (RoHS), 83/264/EEC, and 76/769/EEC)	0.0005	N.D.	-
Dibromobiphenyl ether	%		0.0005	N.D.	-
Tribromobiphenyl ether	%		0.0005	N.D.	-
Tetrabromobiphenyl ether	%		0.0005	N.D.	-
Pentabromobiphenyl ether	%		0.0005	N.D.	-
Hexabromobiphenyl ether	%		0.0005	N.D.	-
Heptabromobiphenyl ether	%		0.0005	N.D.	-
Octabromobiphenyl ether	%		0.0005	N.D.	-
Nonabromobiphenyl ether	%		0.0005	N.D.	-
Decabromobiphenyl ether	%		0.0005	N.D.	-
Total PBDEs (PBDEs) (Polybrominated biphenyl ethers)/Sum of above	%		-	N.D.	-
Total of Mono to Non-brominated biphenyl ether. (Note 5)	%		-	N.D.	0.1



Test Report

AVATACK CO., LTD.
 NO. 21, SANMIN RD., FONGSHAN VILLAGE, HUKOU
 TOWNSHIP, HSINCHU COUNTY 303, TAIWAN (R. O. C.)

Report No. : CE/2006/10501
 Date : 2006/01/10
 Page : 3 of 5

PASS

Test Item (s):	Unit	Method	MDL	Result	Limit of ROHS
				No.1	
Chromium VI (Cr+6)	ppm	UV-VIS after reference to US EPA 3060A.	2	N.D.	1000
Cadmium (Cd)	ppm	ICP-AES after reference to EN 1122, method B:2001 or other acid digestion.	2	N.D.	100
Mercury (Hg)	ppm	ICP-AES after reference to US EPA 3052 or other acid digestion.	2	N.D.	1000
Lead (Pb)	ppm	ICP-AES after reference to US EPA 3050B or other acid digestion.	2	N.D.	1000

- NOTE: (1) N.D. = Not detected (<MDL)
 (2) ppm = mg/kg
 (3) MDL = Method Detection Limit
 (4) " - " = Not Regulation
 (5) Decabromodiphenyl ether (DecaBDE) in polymeric applications is exempted by Commission Decision of 13 Oct 2005 amending Directive 2002/95/EC notified under document 2005/717/EC.
 (6) PBBEs=PBDEs=Polybrominated Diphenyl Ethers=PBDOs=PBBOs.



Test Report

AVATACK CO., LTD.

NO. 21, SANMIN RD., FONGSHAN VILLAGE, HUKOU
TOWNSHIP, HSINCHU COUNTY 303, TAIWAN (R. O. C.)

Report No. : CE/2006/10501

Date : 2006/01/10

Page : 4 of 5

- 1) These samples were dissolved totally by pre-conditioning method according to below flow chart.
- 2) Name of the person who made measurement: Anren Lee
- 3) Name of the person in charge of measurement: Daniel Yeh

Method 1: Flow Chart of Digestion for heavy metal analysis

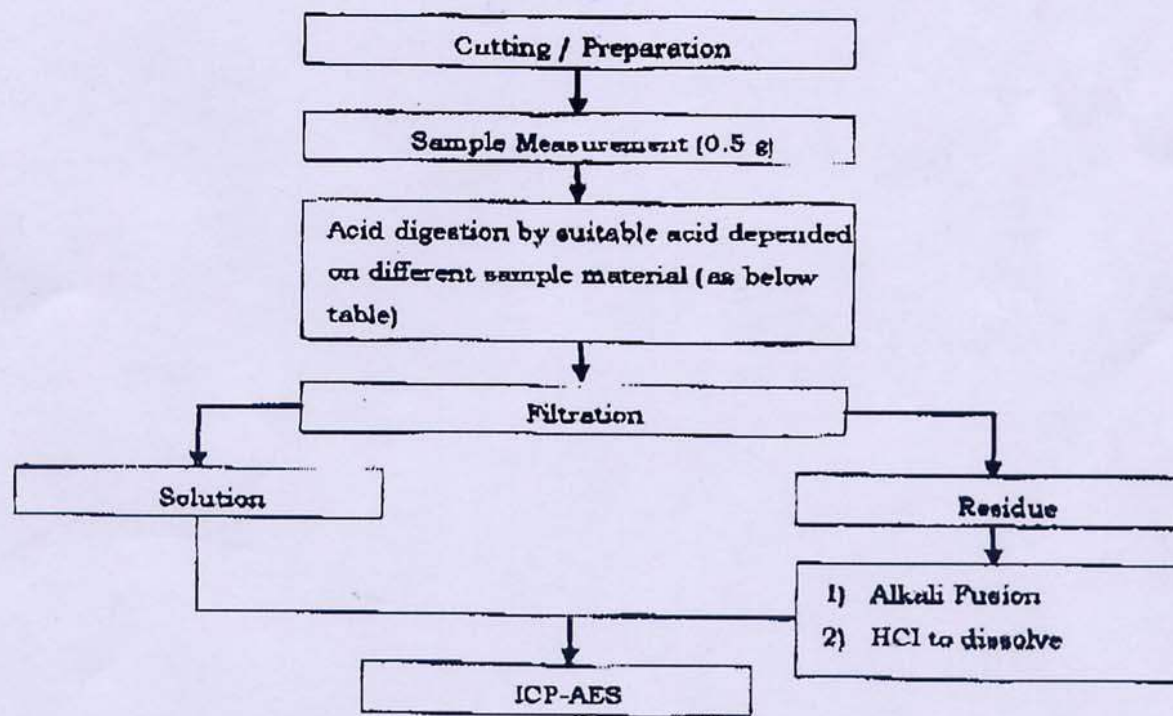

Steel, copper, aluminum, solder	Agua regia, HNO ₃ , HCl, HF, H ₂ O ₂
Glass	HNO ₃ /HF
Gold, platinum, palladium, ceramic	Aqua regia
Silver	HNO ₃
Plastic	H ₂ SO ₄ , H ₂ O ₂ , HNO ₃ , HCl
Others	Any acid to total digestion

SONY

SONY
THERMAL
TRANSFER
RIBBON

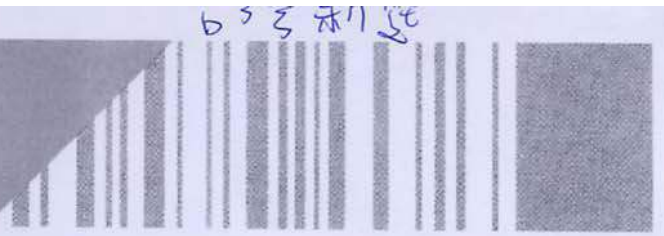

TECHNICAL
REPORT

TR4085

搬運中

		High density printing	Measure method	
Ribbon property	Total thickness (μm)	8.6	Micrometer scale	
	Substrate thickness (μm)	4.8		
	Ink thickness (μm)	3.5		
	Ink melting point (°C)	80	DSC method	
	Transmission density	≦1.4	Macbeth scale	
Printing property	Required pointing energy (mj/mm ²)	14	Using standard printing of which printing speed at 3"/sec Label:FASSON 1C ※1 Macbeth scale ※2 Element rate = $\frac{\text{In spec element}}{\text{Element}} \times 100$	
	Image density ^{※1}	1.8		
	Element ratio (%) ^{※2}	100		
	Coated label stock	NA55 (210min.)	○	Quality of transferability of 1dot thin bars, letters and solidness(Beck smoothness)
		FASSON 1C (350min.)	◎	
		SK coat (720min.)	◎	
PET label stock	FLEXCON T/C387	○		
Durability ^{※3}	Friction resistance	Cotton contamination density	0.05	200g /2cm ² load×100reciprocation
	Heat-pressing resistance	Cotton contamination density	0.15	80°C×2,000g/cm ² load×10sec
	Heat resistance	80°C×3days	○	Scanning by pen scanner ○ : Good ※3 label:using FASSON 1C
	Pen scanner	50times	○	
	Water resistance	Dipping for 1HR	○	
	Ethanol resistance	Dipping for 10min.	○	
	Cold resistance	-20°C×12HR 50°C×12HR 3cycles	○	
Others	Usage condition	5~35°C. very good results		
	Storage condition	5~35°C, 20~85%RH one year		

※:Specifications may be changed without notice.

Sony Chemicals Corporation

6-3,Nihombashi-Muromachi 1-chome,Chuo-ku,Tokyo 103 Japan
Tel:81(3)3279-0434 Telex:222-4397 SONY CH Fax:81(3)3279-0510

Sony Chemicals Corporation of America

1001 Technology Drive Mount Pleasant, Pennsylvania 15666
Tel:412(696)-7500 Fax:412(696)-7555

Sony Chemicals Europe B.V.

Diamantlaan 27,2132 WV Hoofddorp,The Netherlands
Tel:31(0)2503-50606 Fax:31(0)2503-20115

Sony Chemicals Singapore PTE LTD.

Block 1022 Tai seng Avenue, Tai Seng Industrial Estate
02-3530 Singapore 534415 Tel:382-1500 Fax:382-1750

SONY

SONY
THERMAL
TRANSFER
RIBBON



PRODUCT
DATA
SHEET

TR4085

Use of bar code systems is getting wider year by year in areas of factory automation, physical distribution and retail market. Demand is increasing for thermal transfer ribbons to produce high quality smudge/scratch resistant images on various material of labels and tags. Such demand has encouraged Sony to produce TR4085, a truly unique ribbon that offers remarkable "void free" bar code /human readable imaging and smudge/scratch resistance on polyethylene wrapping bags. Sony TR4085 is applicable for both paper and plastic label in satisfying bar code requirements.

Specific Features of TR4085

- Ideal for polyethylene wrapping bags and normal paper labels. High density and clear printing is possible.
- Particularly high density printing combined with smudge/scratch durability.
- Special printing condition is not necessary on the part of printers. The ribbon can be mounted on any existing major thermal transfer bar code printers.
- "Void free" bar code imaging.

Print sample

Features'Chart

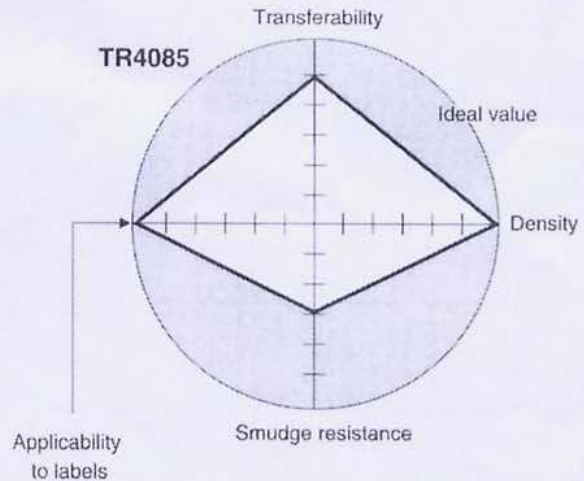

Sony Chemicals Corporation

6-3, Nihombashi-Muromachi 1-chome, Chuo-ku, Tokyo 103 Japan
Tel: 81(3)3279-0434 Telex: 222-4397 SONY CH Fax: 81(3)3279-0510

Sony Chemicals Corporation of America

1001 Technology Drive Mount Pleasant, Pennsylvania 15666
Tel: 412(696)-7500 Fax: 412(696)-7555

Sony Chemicals Europe B.V.

Diamantlaan 27, 2132 WV Hoofddorp, The Netherlands
Tel: 31(0)2503-50606 Fax: 31(0)2503-20115

Sony Chemicals Singapore PTE LTD.

Block 1022 Tai Seng Avenue, Tai Seng Industrial Estate
#02-3530 Singapore 534415 Tel: 382-1500 Fax: 382-1750