

REVISIONS				
#	DATE	DESCRIPTION	DATE	APP'D
A3		REVISED PER ECO-13-008133	17MAR2013	DLD DCM
A4		REVISED PER ECO-17-001034	25JAN2017	DLD DCM
A5		REVISED PER ECO-17-007766	30MAY2017	DLD DCM

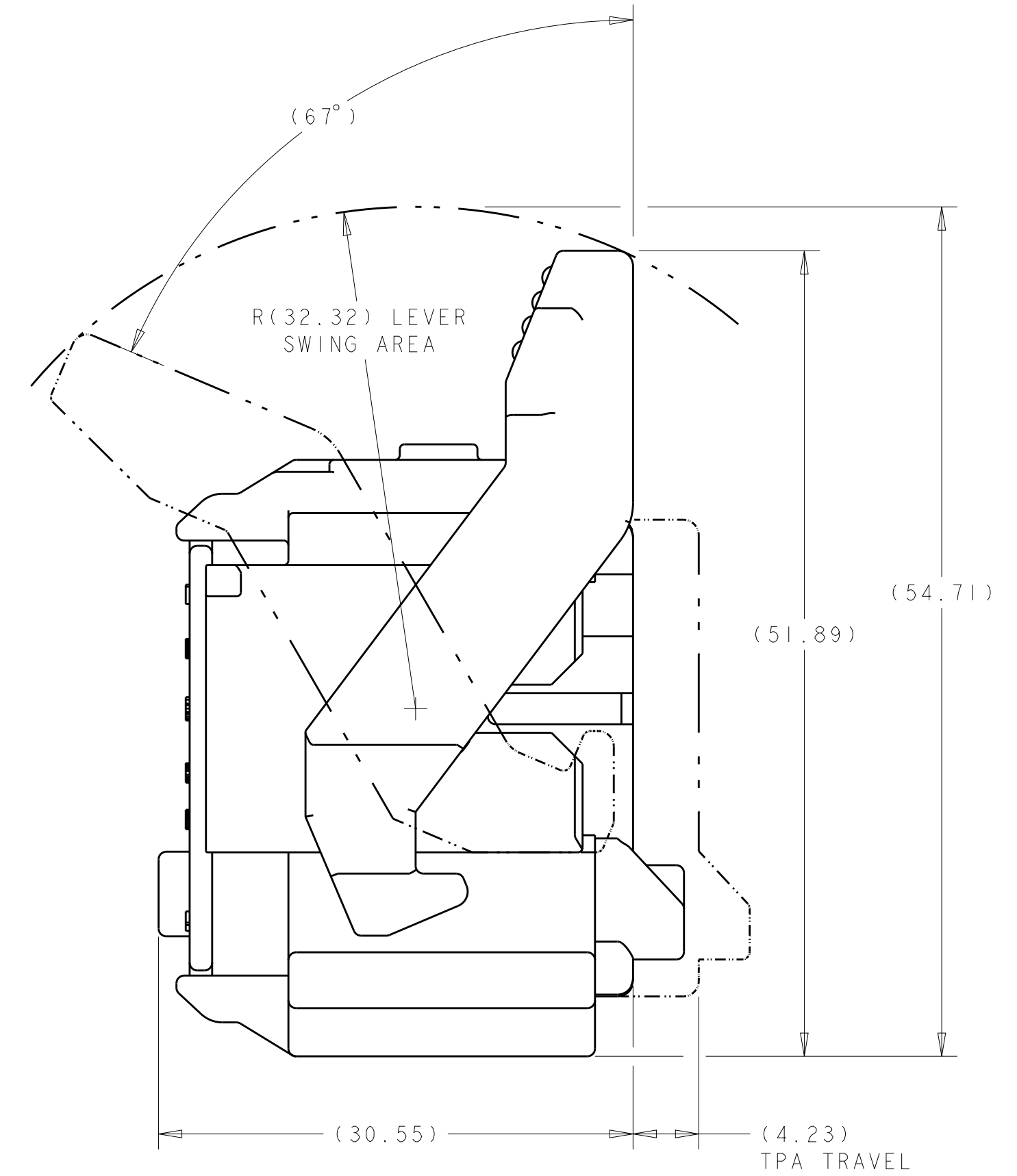

LEVER AND TPA SHOWN IN THEIR LATCHED POSITIONS FOR REFERENCE ONLY

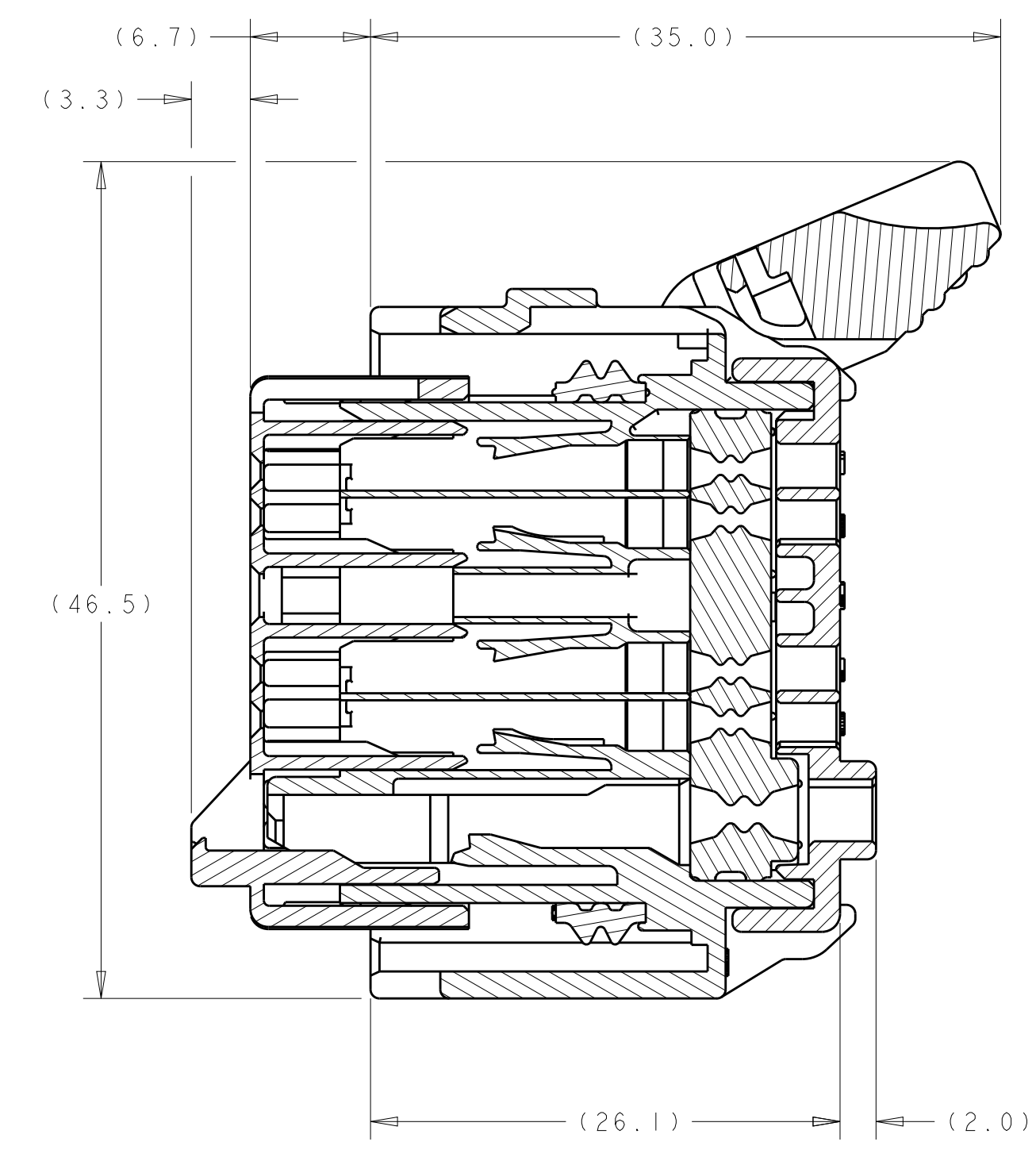
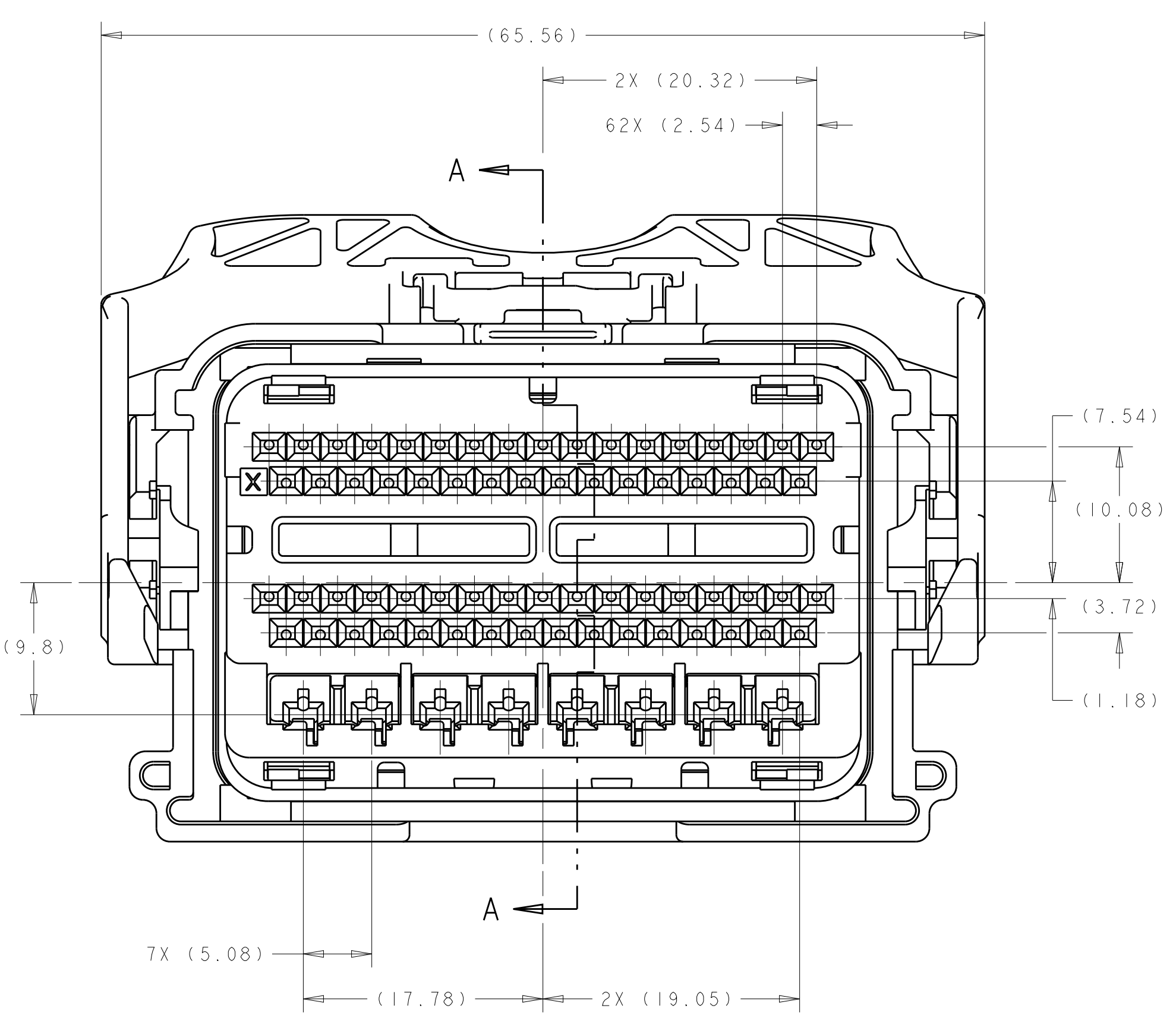

SECTION A-A SHOWING THE TPA AND LEVER IN THEIR PRE-LATCHED POSITIONS (DELIVERY CONDITION)

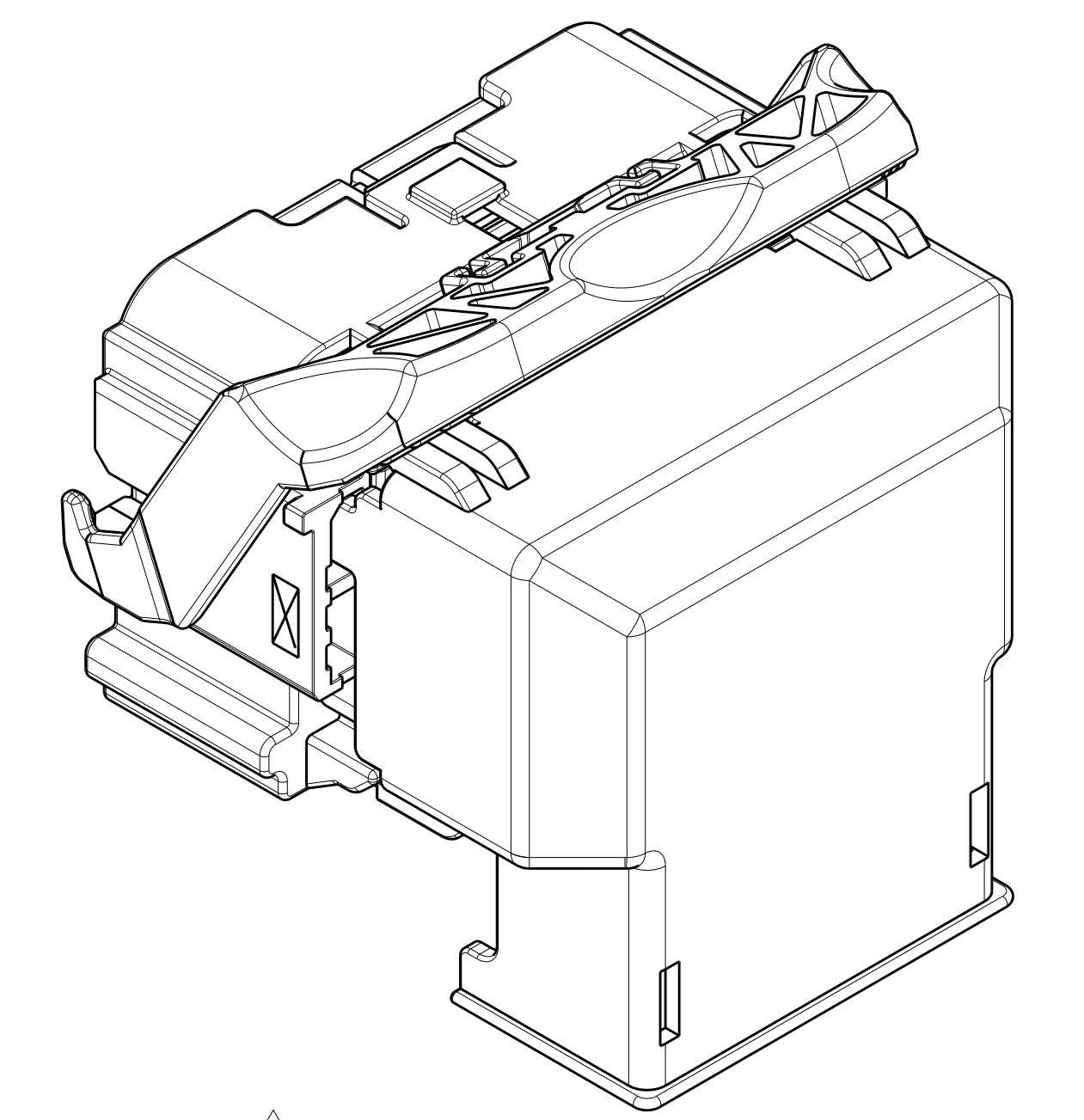
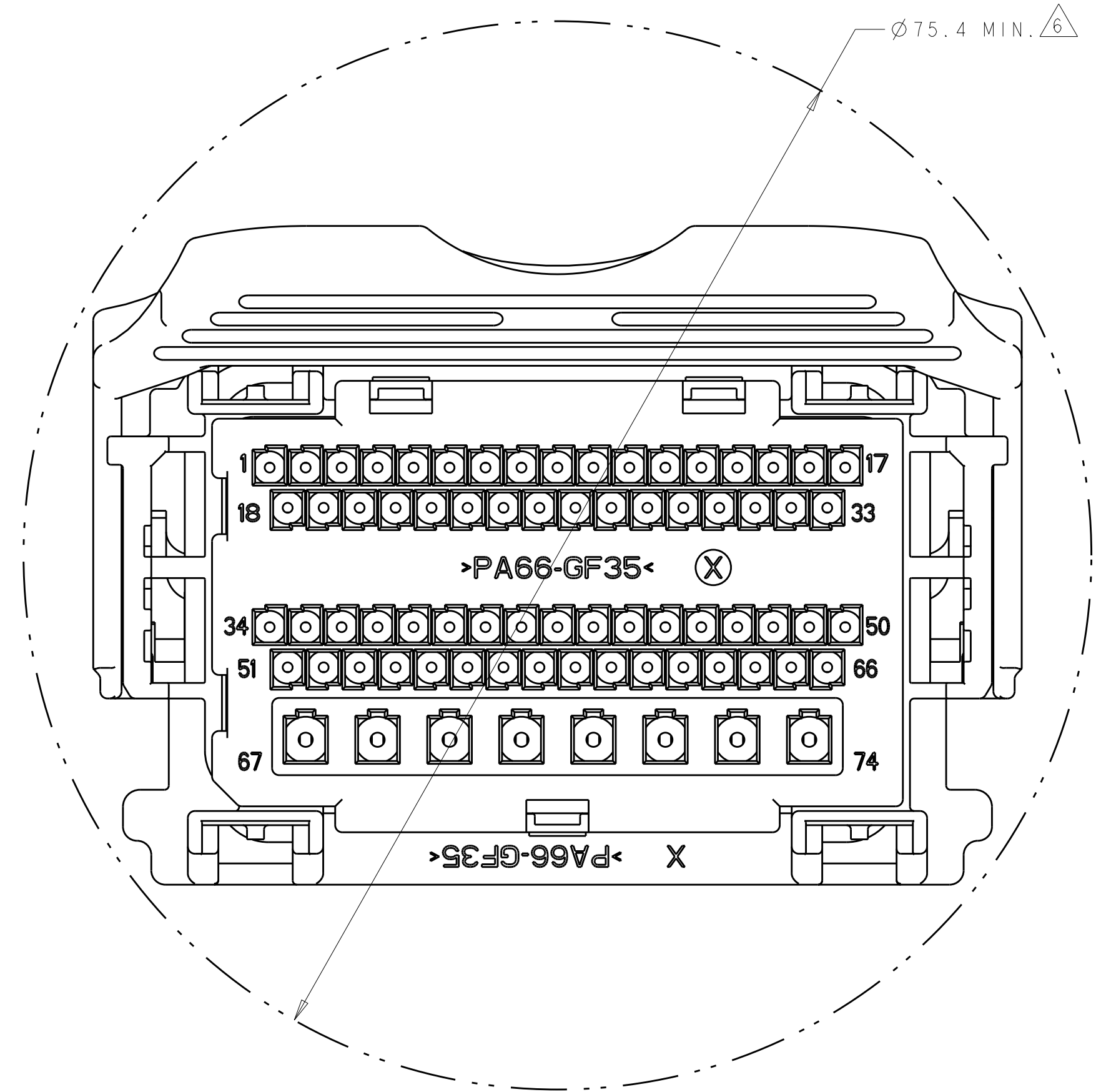

ISOMETRIC VIEW SHOWING THE OPTIONAL 90° EXIT WIRE GUIDE SCALE 2:1

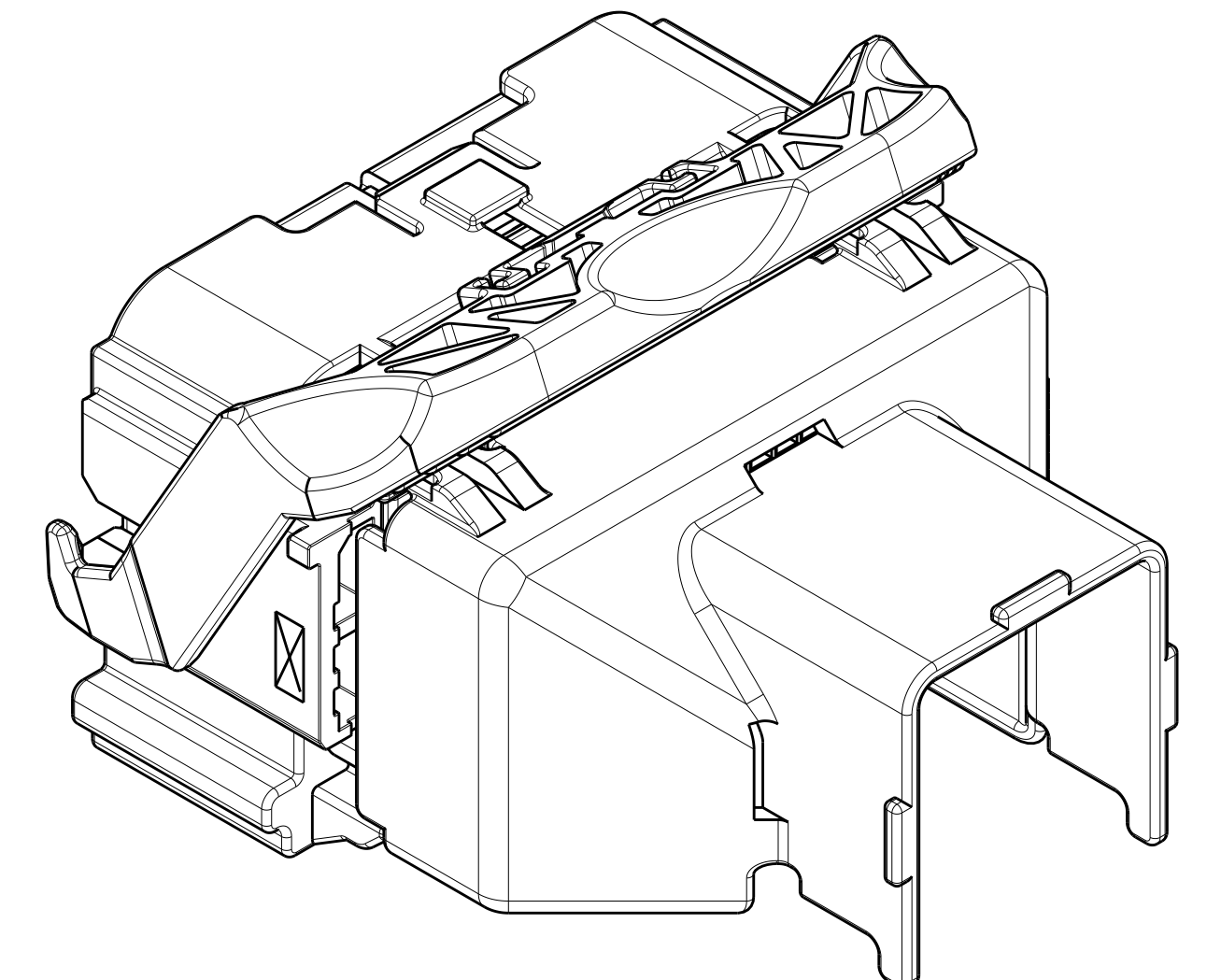
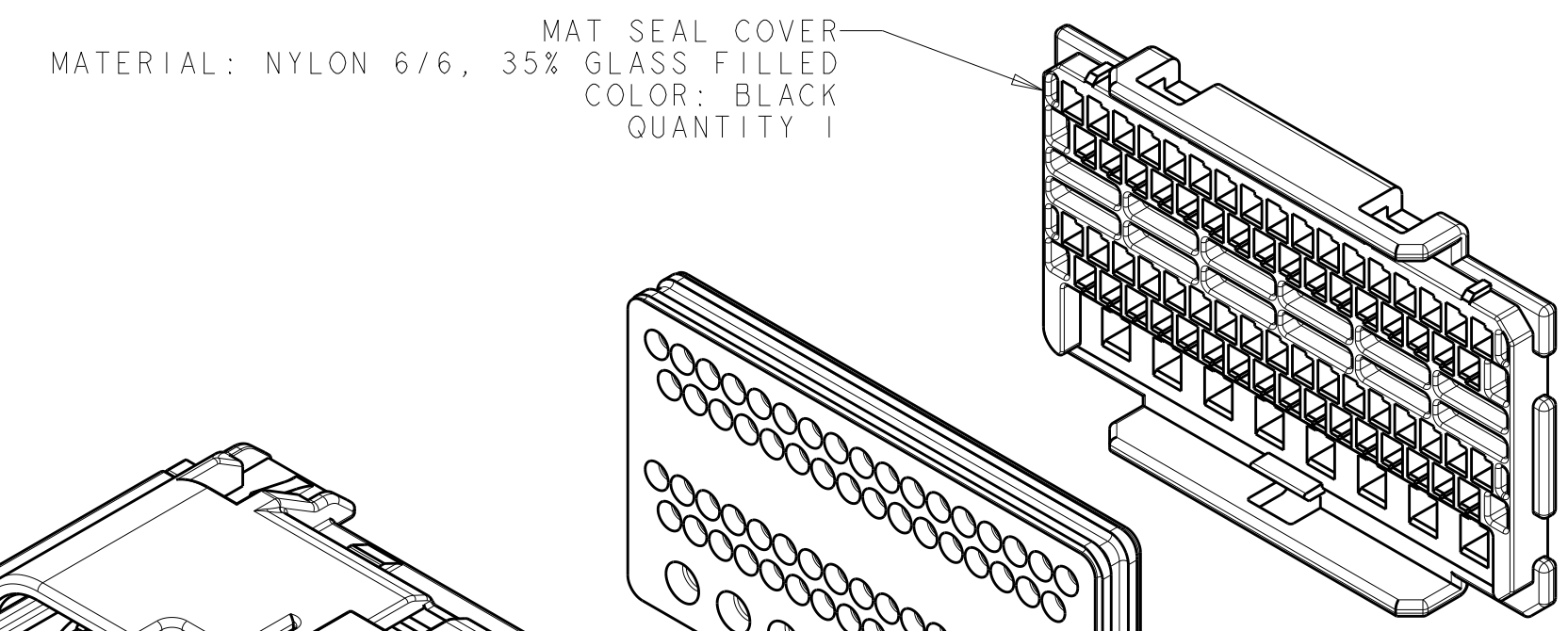
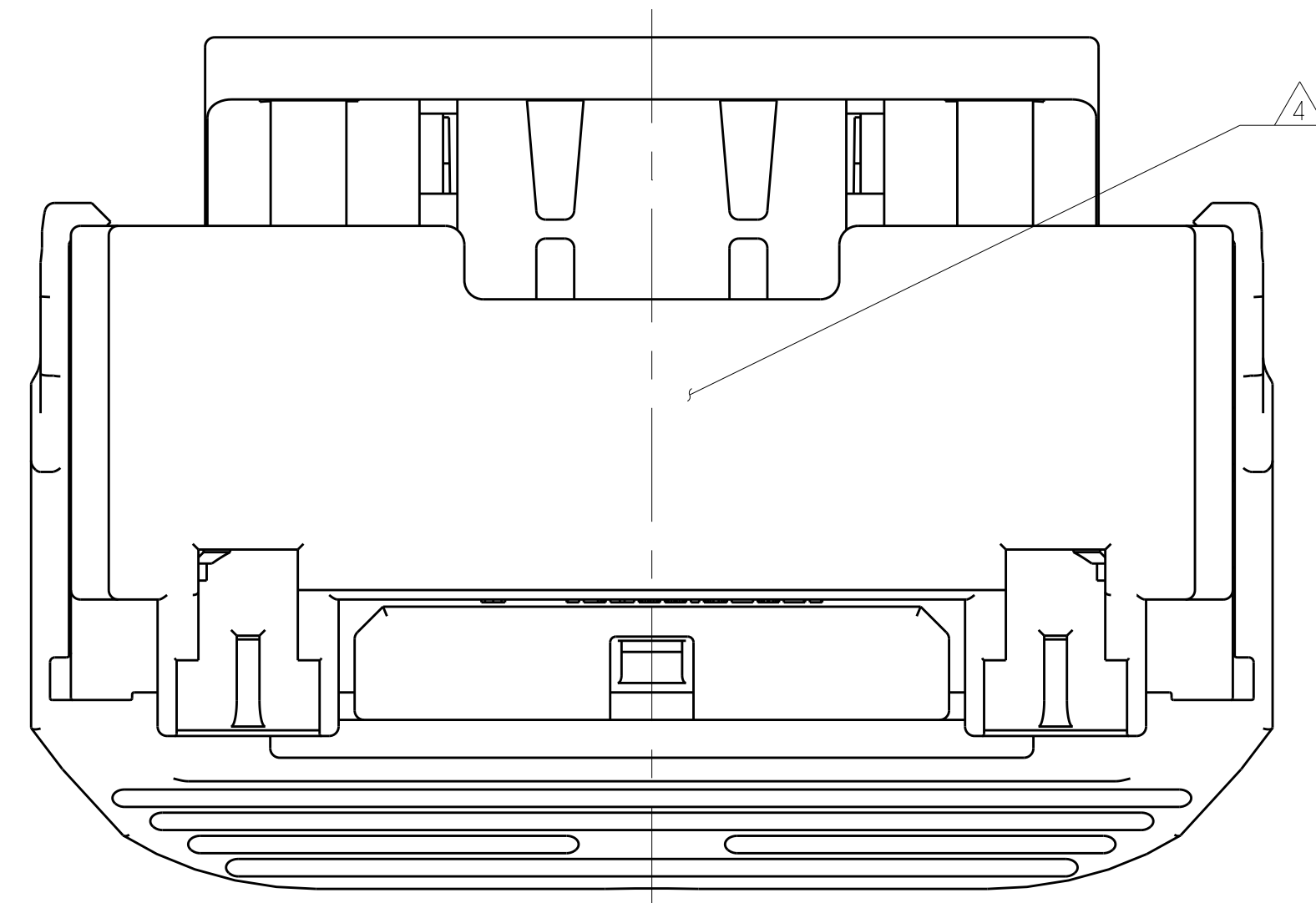

ISOMETRIC VIEW SHOWING THE OPTIONAL IN-LINE EXIT WIRE GUIDE SCALE 2:1

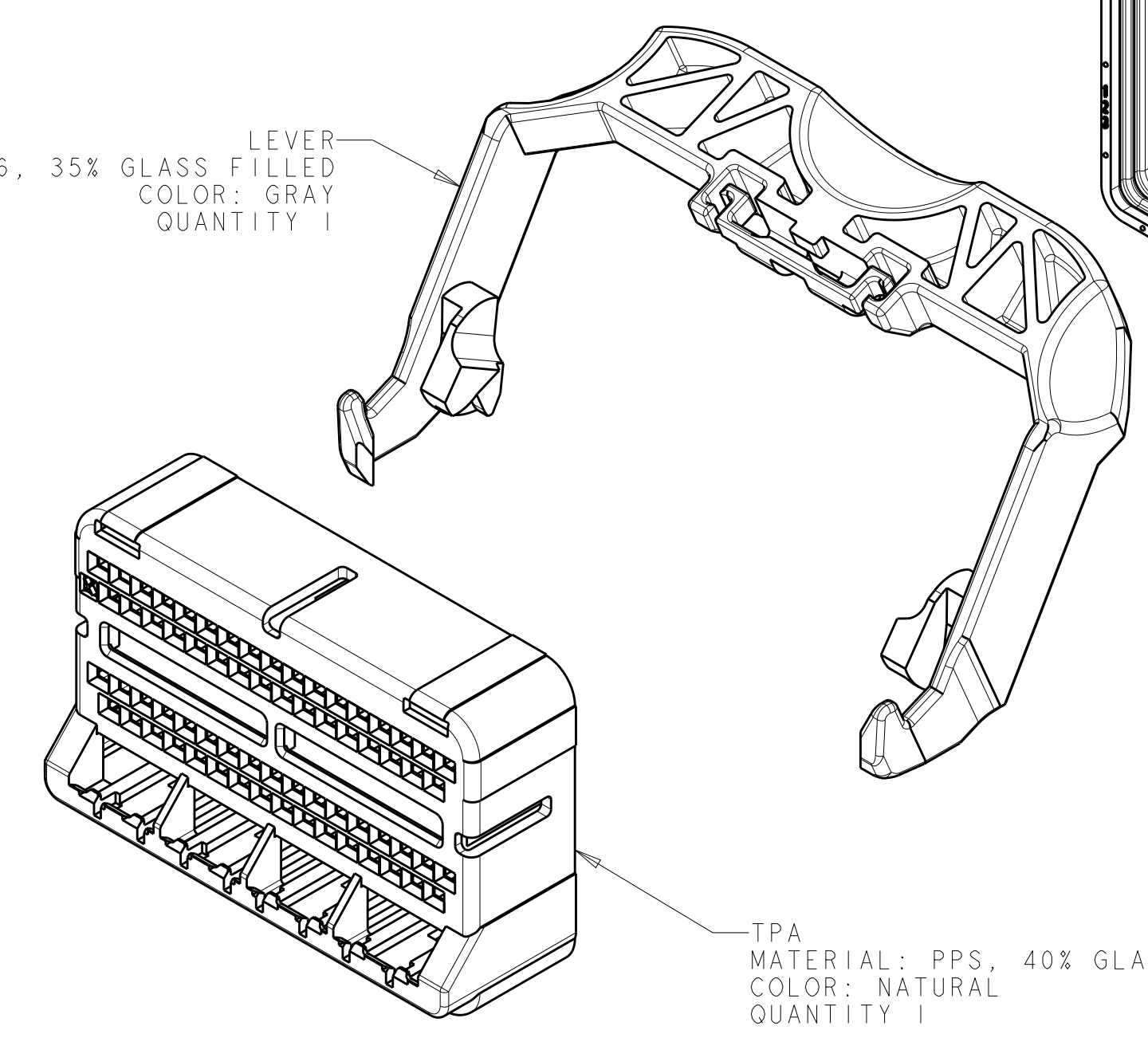

EXPLODED ISOMETRIC VIEW PART NUMBER: 776905-1 SHOWN FOR REFERENCE ONLY SCALE 2:1

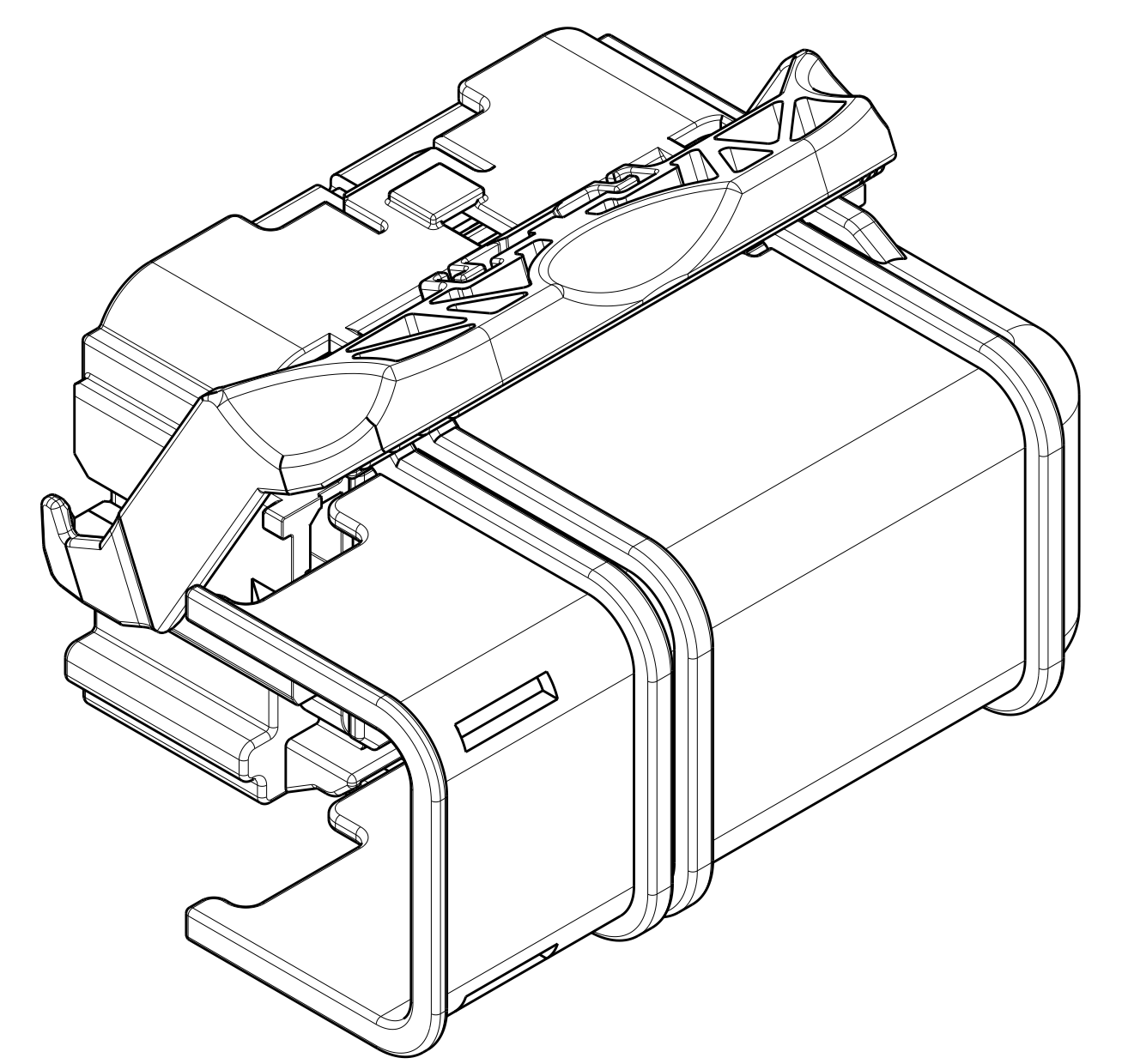

ISOMETRIC VIEW SHOWING THE OPTIONAL SIDE EXIT WIRE GUIDE SCALE 2:1

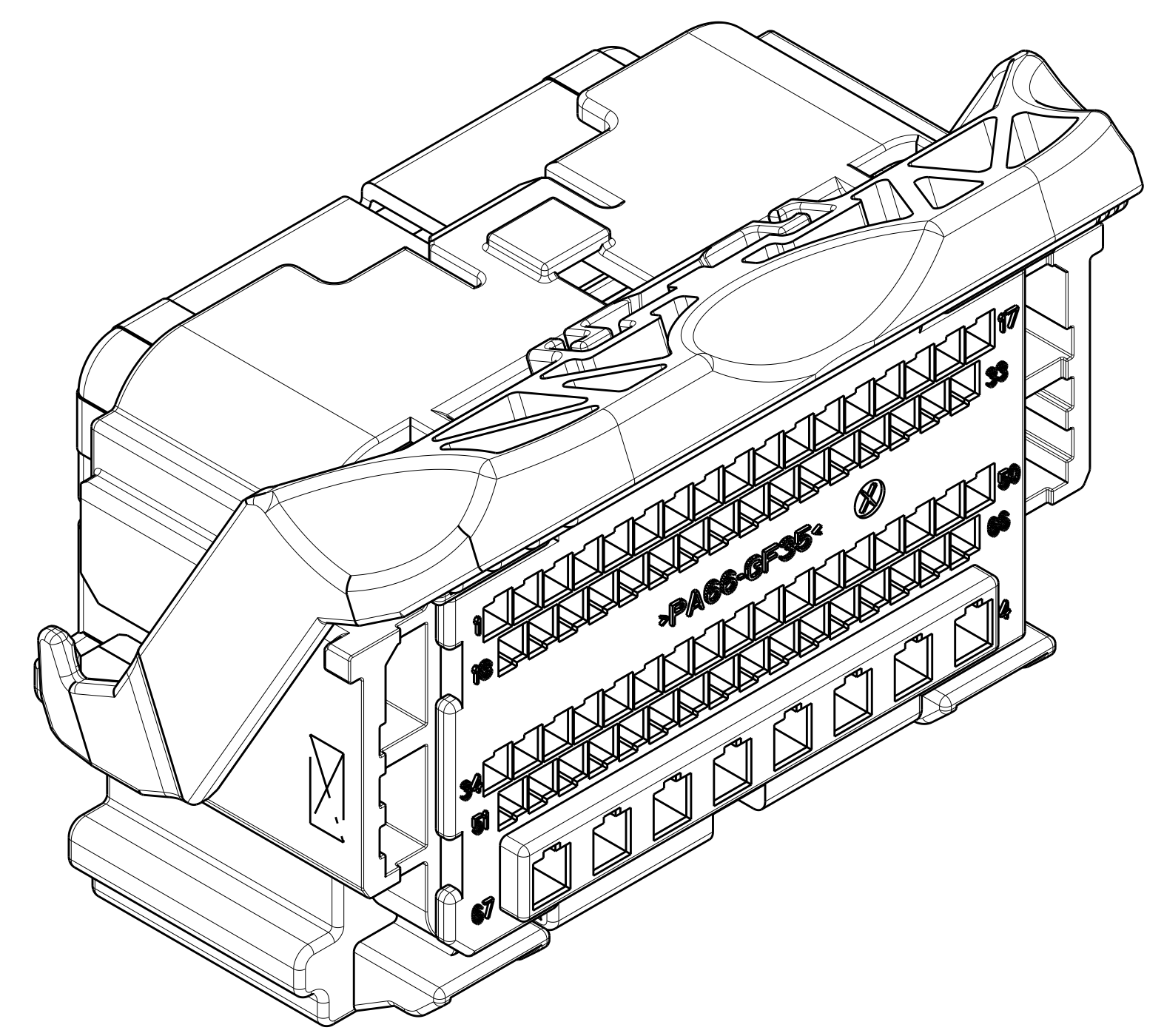
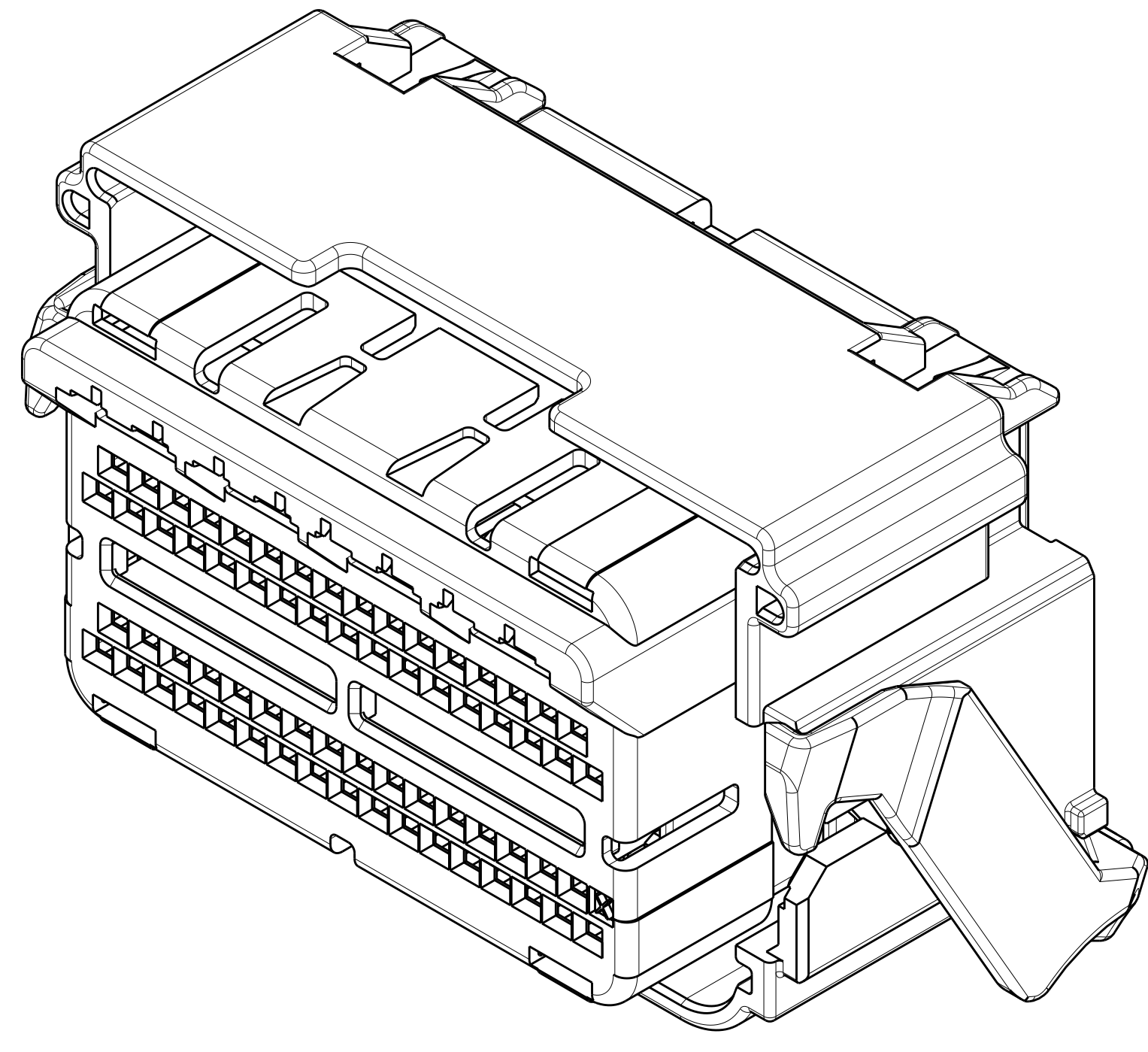

ISOMETRIC VIEWS

- PART NUMBER 776905-1 SHOWN ON THE DRAWING.
- THE TPA AND LEVER ARE SHIPPED IN THEIR PRE-LATCHED POSITIONS.
- ASSEMBLIES ARE SHIPPED IN TRAYS.
- TRACEABILITY CODE (YY = TWO DIGIT YEAR, JJJ = THREE DIGIT JULIAN DAY, HH = TWO DIGIT MILITARY HOUR) AND CUSTOMER PART NUMBER PRINTED IN THIS LOCATION AT ASSEMBLY.
- APPLICABLE WIRE ROUTING GUIDE(S): (SOLD SEPARATELY)
1438133-1 = 90° DEGREE EXIT AWAY FROM THE LEVER
1488374-1 = IN-LINE EXIT
776880-1 = SIDE EXIT, CAN BE ROUTED LEFT OR RIGHT.
SEE SHEET 3 FOR AVAILABLE OPTIONS.
- MINIMUM FEED THROUGH CONDITION WITH 1mm CLEARANCE ALL AROUND. THIS FEED THROUGH CONDITION APPLIES TO ALL ASSEMBLIES WITH OR WITHOUT ANY OF THE WIRE ROUTING GUIDE OPTIONS.
- FOR A LIST OF APPLICABLE CONTACT TERMINALS (SOLD SEPARATELY) SEE THE APPLICABLE TERMINAL TABLE.
- APPLICABLE HEADER INTERFACE DRAWING 1456714 IS AVAILABLE UPON REQUEST. A COPY OF THIS DRAWING CAN BE OBTAINED FROM THE TYCO ELECTRONICS PRODUCT MANAGER, VIA YOUR TYCO ELECTRONICS SALES REPRESENTATIVE OR CUSTOMER SERVICE.
- THIS ASSEMBLY HAS NOT PASSED VALIDATION TESTING.
- TYCO ELECTRONICS TAKE EXCEPTION TO THE USCAR-2 MATING AND UN-MATING FORCES REQUIREMENTS UNTIL TESTING CAN BE CONDUCTED TO DETERMINE THE ACTUAL VALUES OF THE MATING AND UN-MATING FORCES.
- REFERENCE TYCO ELECTRONICS INSTRUCTION SHEET 408-8893.

APPLICABLE TERMINALS (FOR REFERENCE ONLY)					
PART NUMBER	SUPPLIER	NOMINAL TERMINAL SIZE	PLATING	METRIC WIRE SIZES	SAE WIRE SIZES
33012-0002	MOLEX	1.5	TIN	0.50 - 1.50mm ²	16-20AWG
1393367-2	TYCO ELECTRONICS	0.64	SILVER	0.22 - 0.35mm ²	22AWG
1393366-2	TYCO ELECTRONICS	0.64	SILVER	0.50 - 0.75mm ²	18-20AWG
1393365-1	TYCO ELECTRONICS	0.64	GOLD	0.50 - 0.75mm ²	18-20AWG
1393364-1	TYCO ELECTRONICS	0.64	GOLD	0.22 - 0.35mm ²	22AWG

THIS DRAWING IS A CONTROLLED DOCUMENT.

DATE: 31 AUG 2006	BY: FORSLER
DATE: 31 AUG 2006	CHK: VALASEK
DATE: 31 AUG 2006	APP'D: RAY

NAME: PLUG ASSEMBLY, 74 WAY, SEALED, HYBRID, FEMALE

SIZE: CASE CODE: DRAWING NO: A000779-1

CUSTOMER DRAWING

SCALE: 3:1 SHEET 1 OF 3

SEE SHEET 2 FOR AVAILABLE PIN-OUT OPTIONS

REVISIONS			
P	LTN	DESCRIPTION	DATE
-	-	SEE SHEET 1	-

△ WIRE ROUTING GUIDE OPTIONS

KEYING OPTIONS

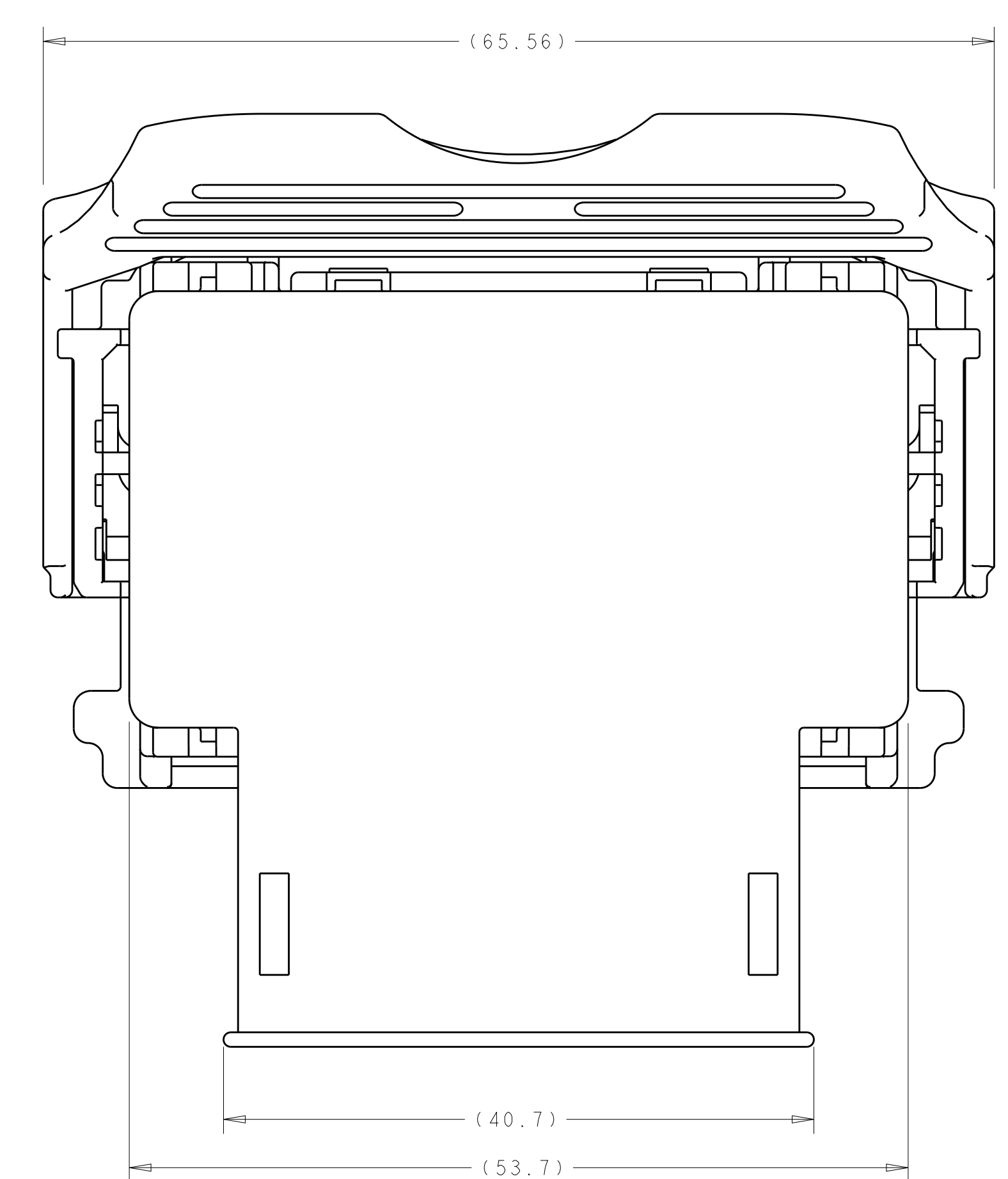
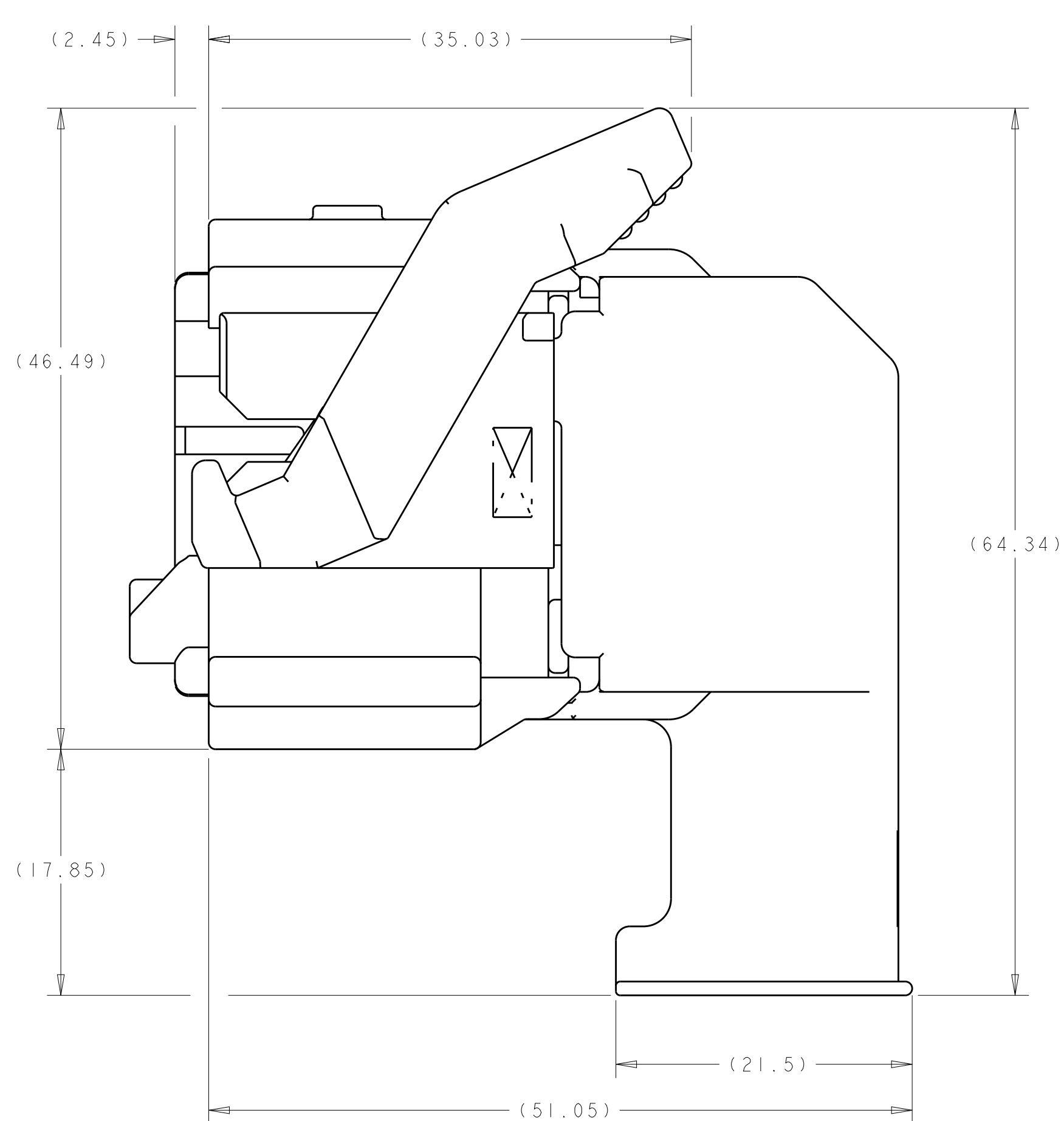

OPTION #1: 90° EXIT

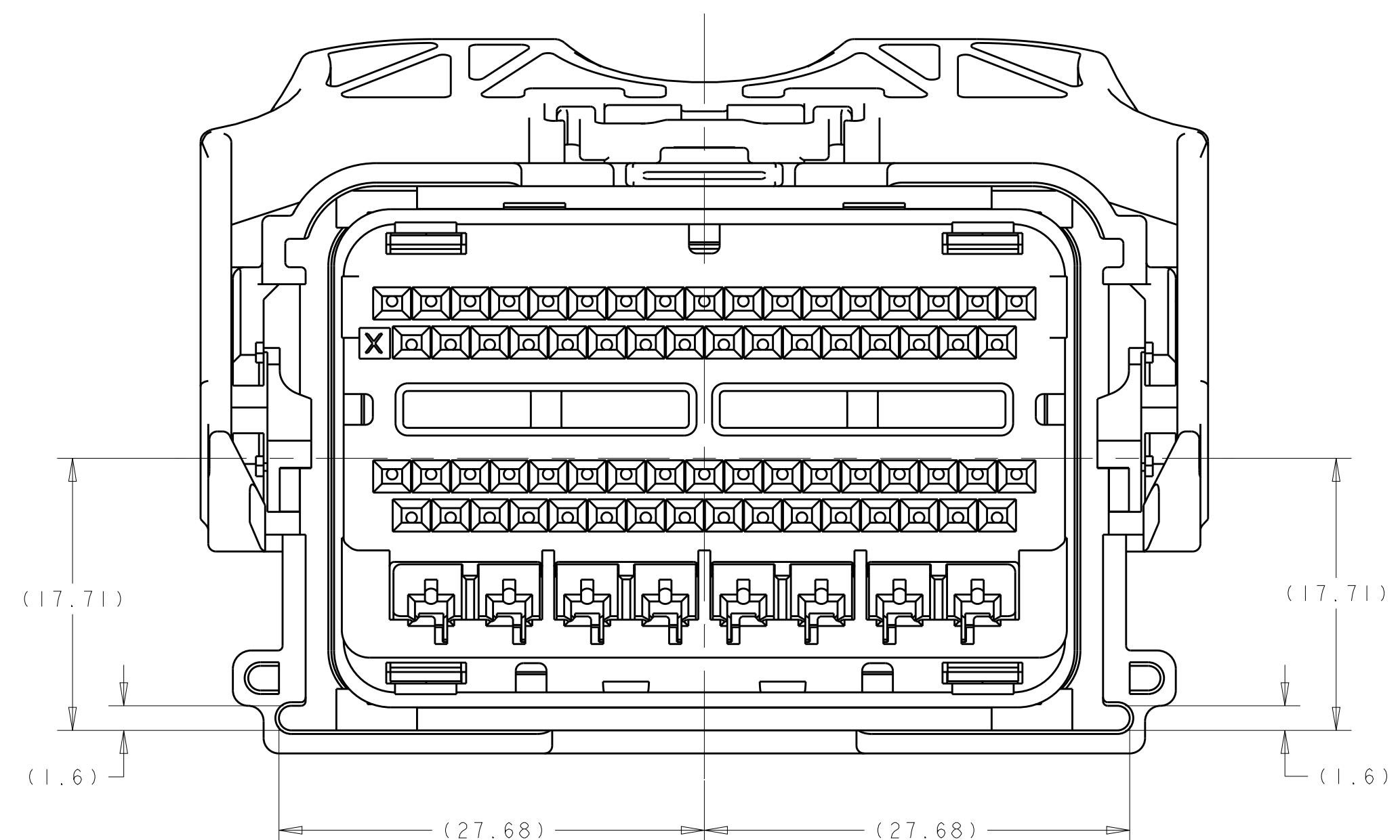

KEY A

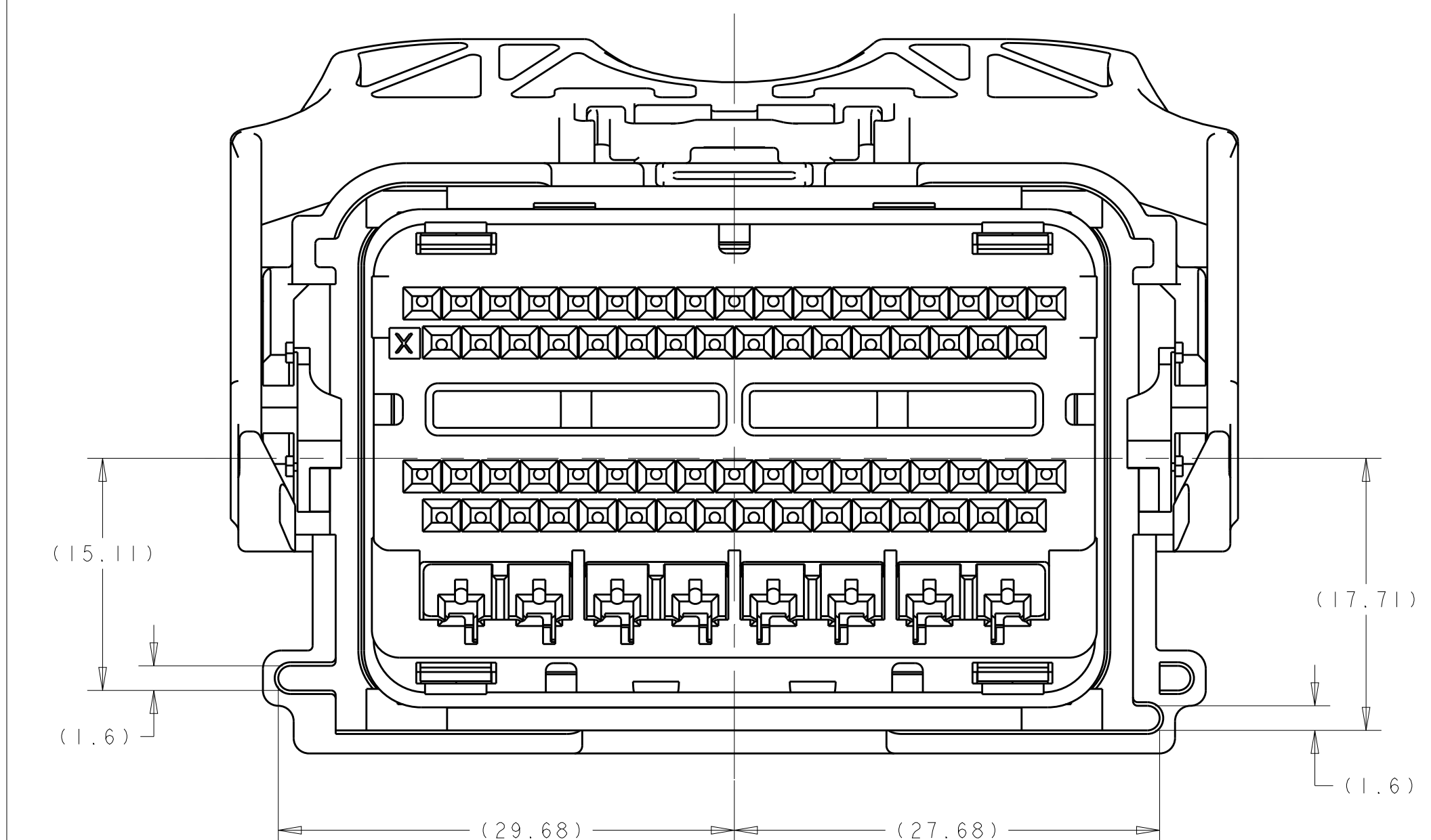

KEY B

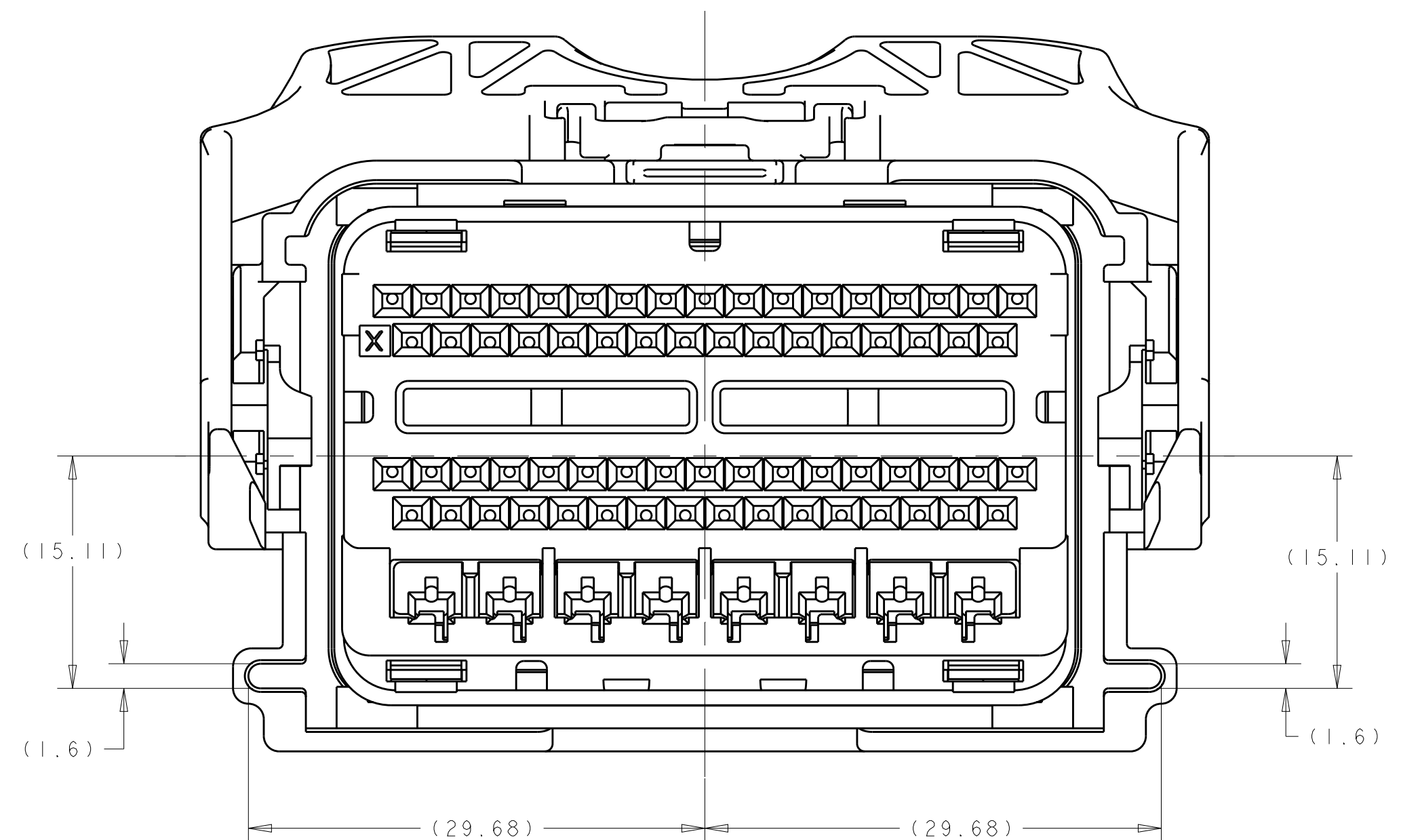

KEY C

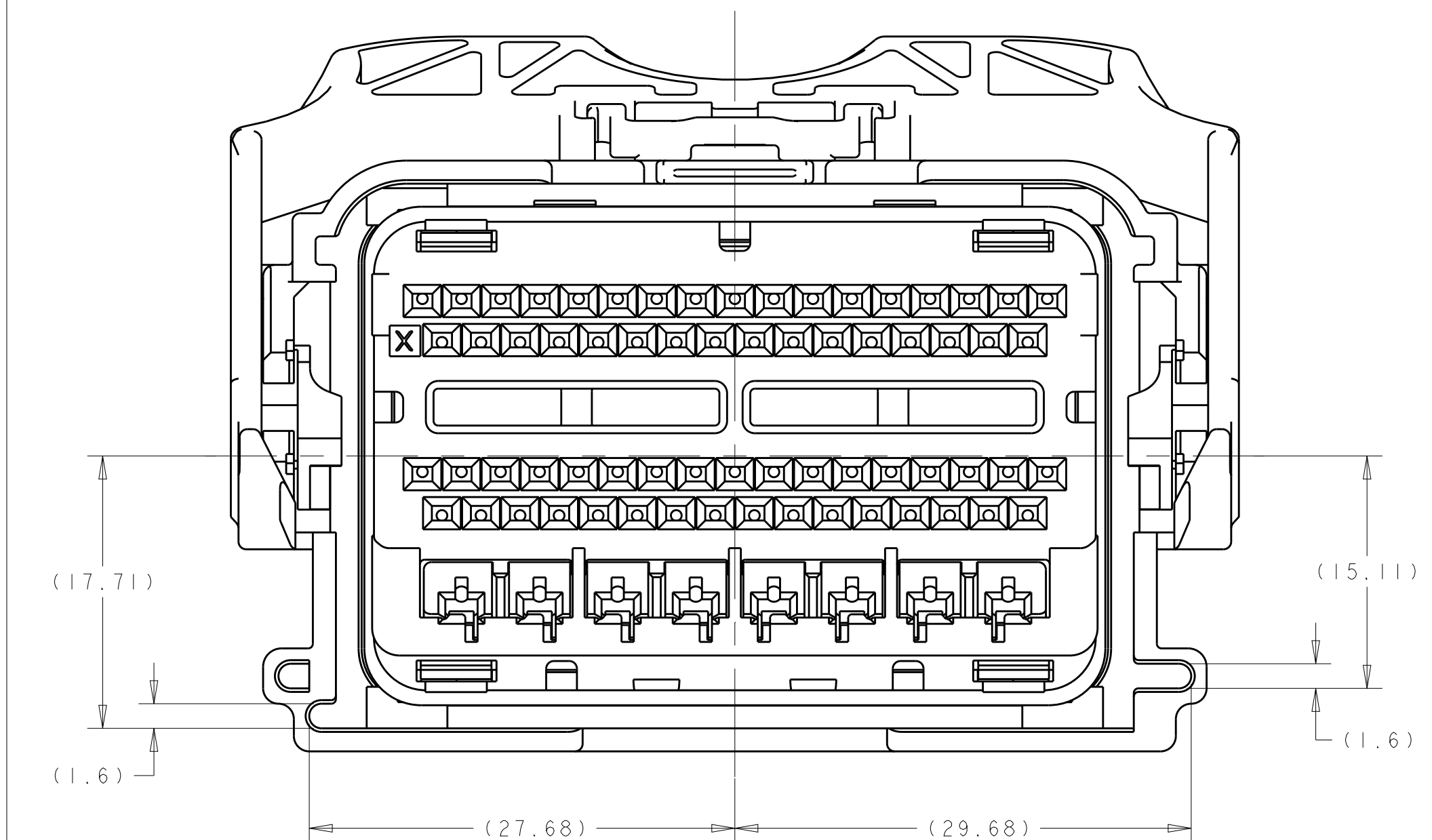

KEY D

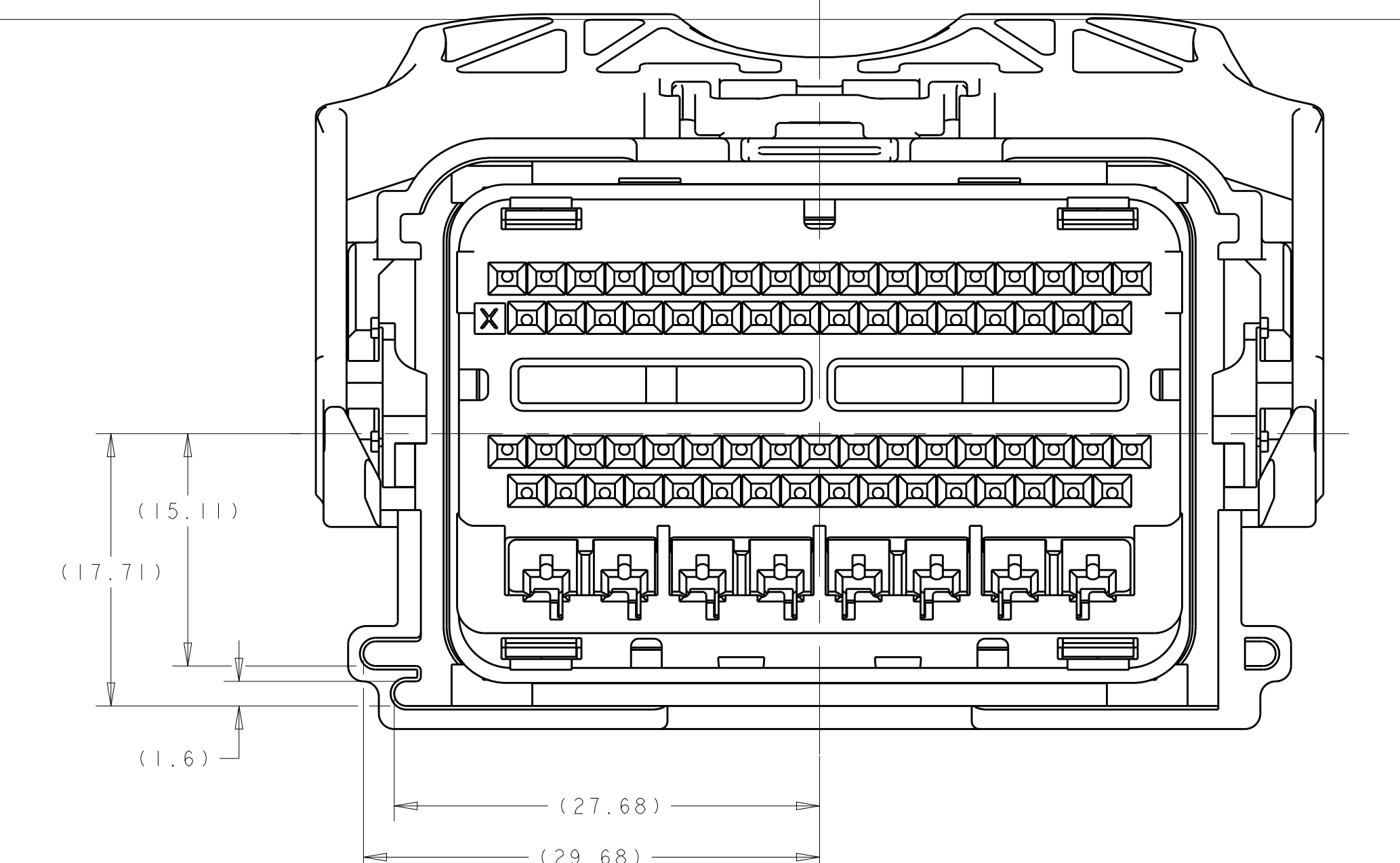

KEY E

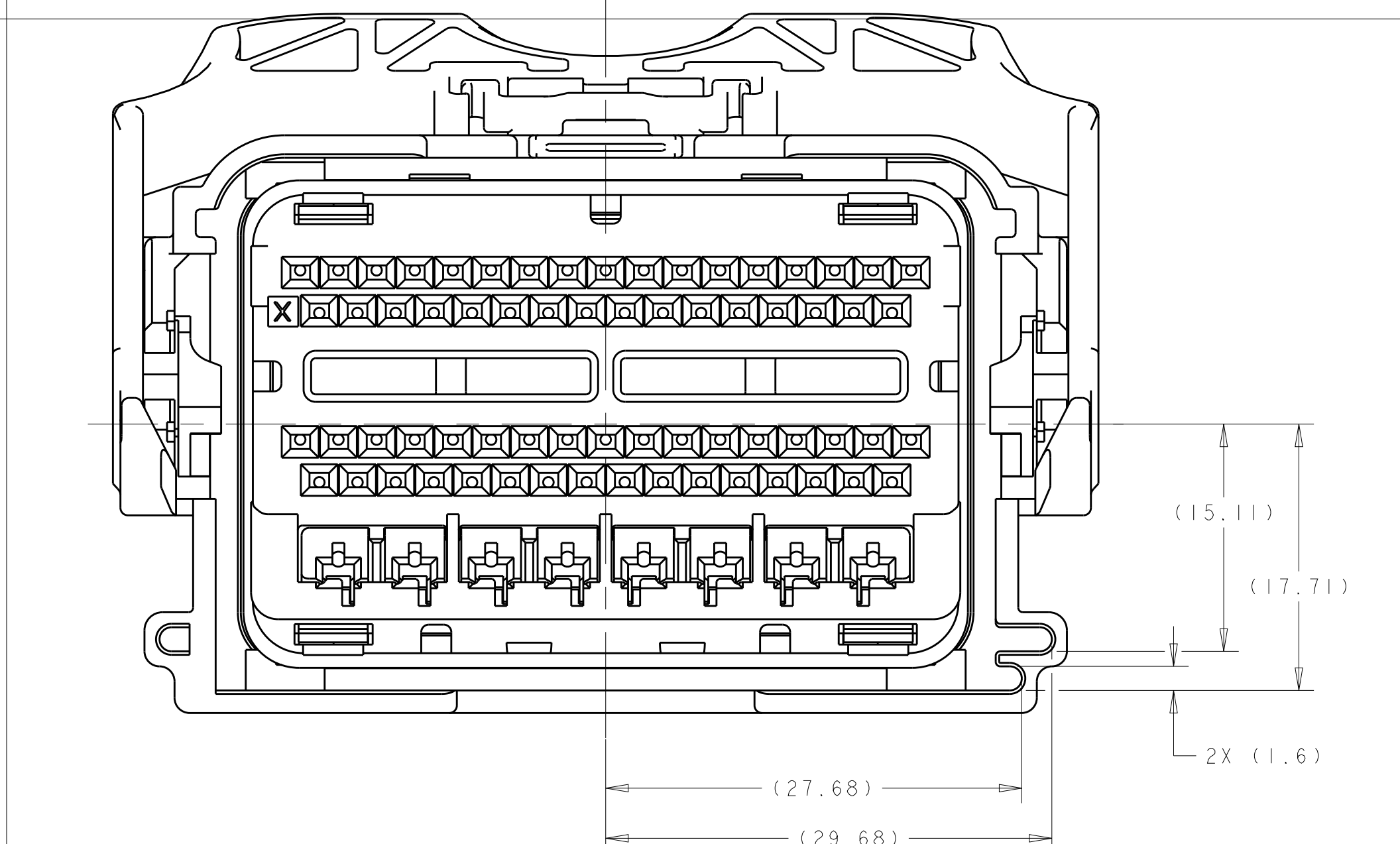

KEY F

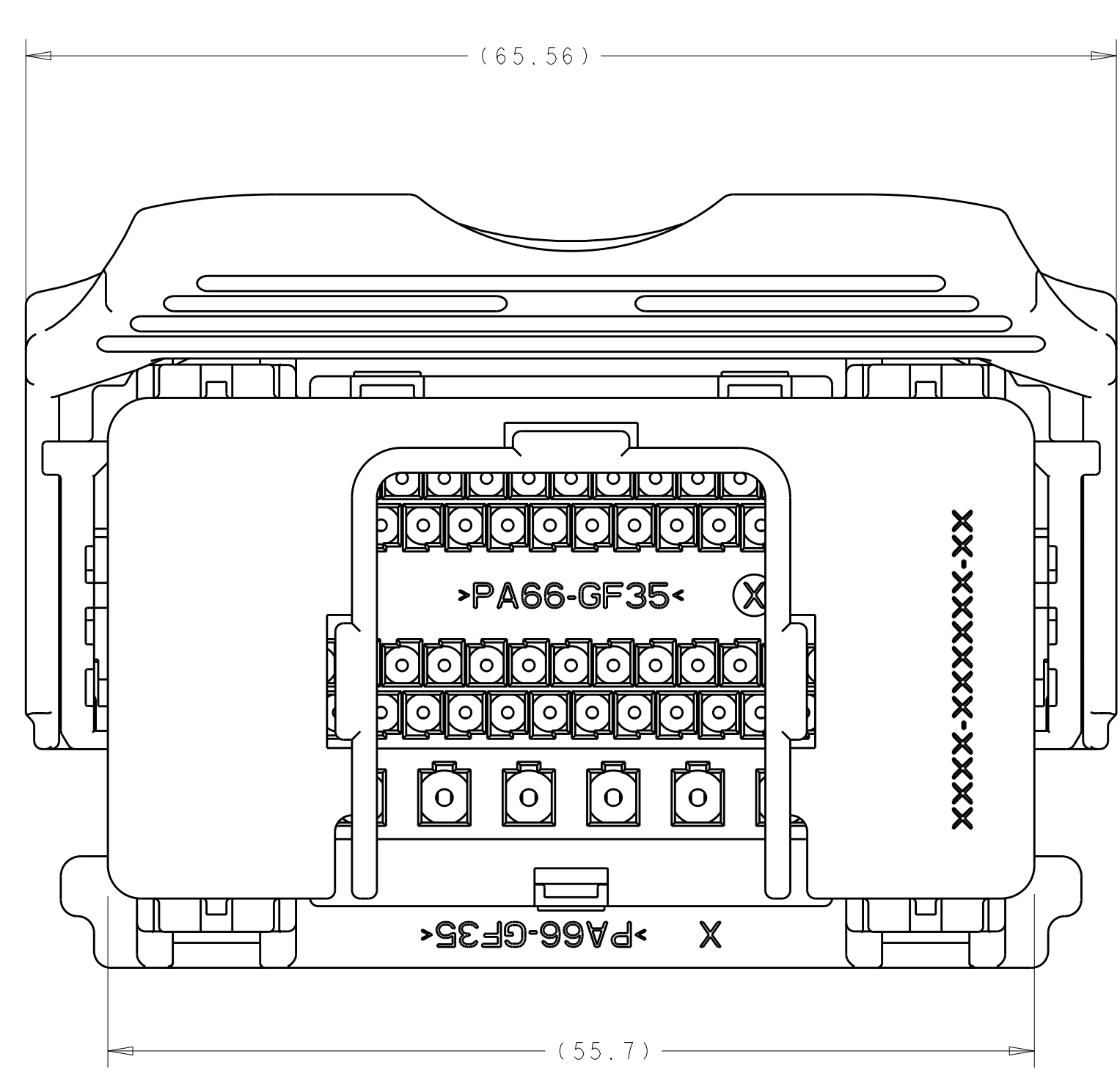
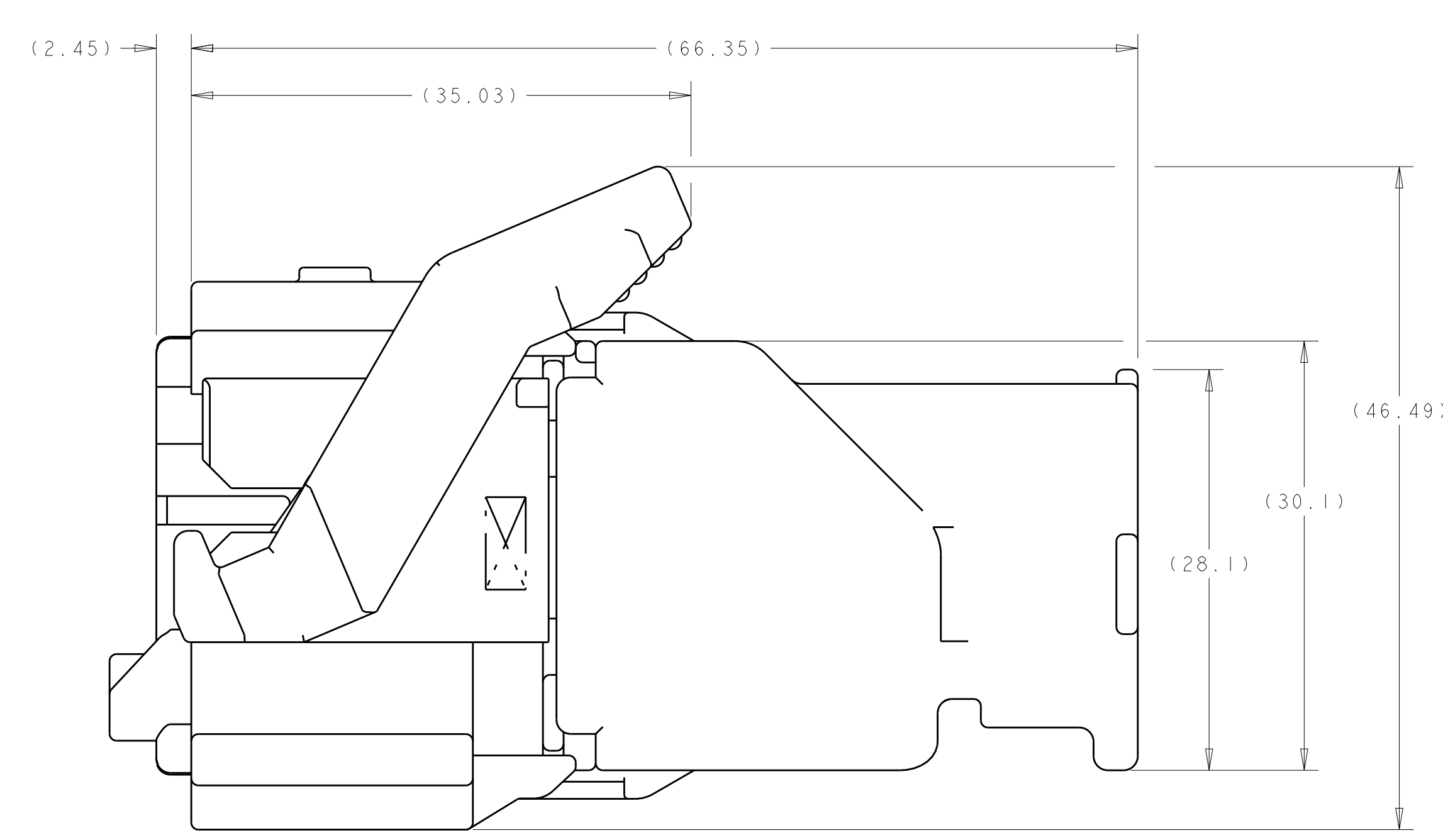

OPTION #2: IN-LINE EXIT

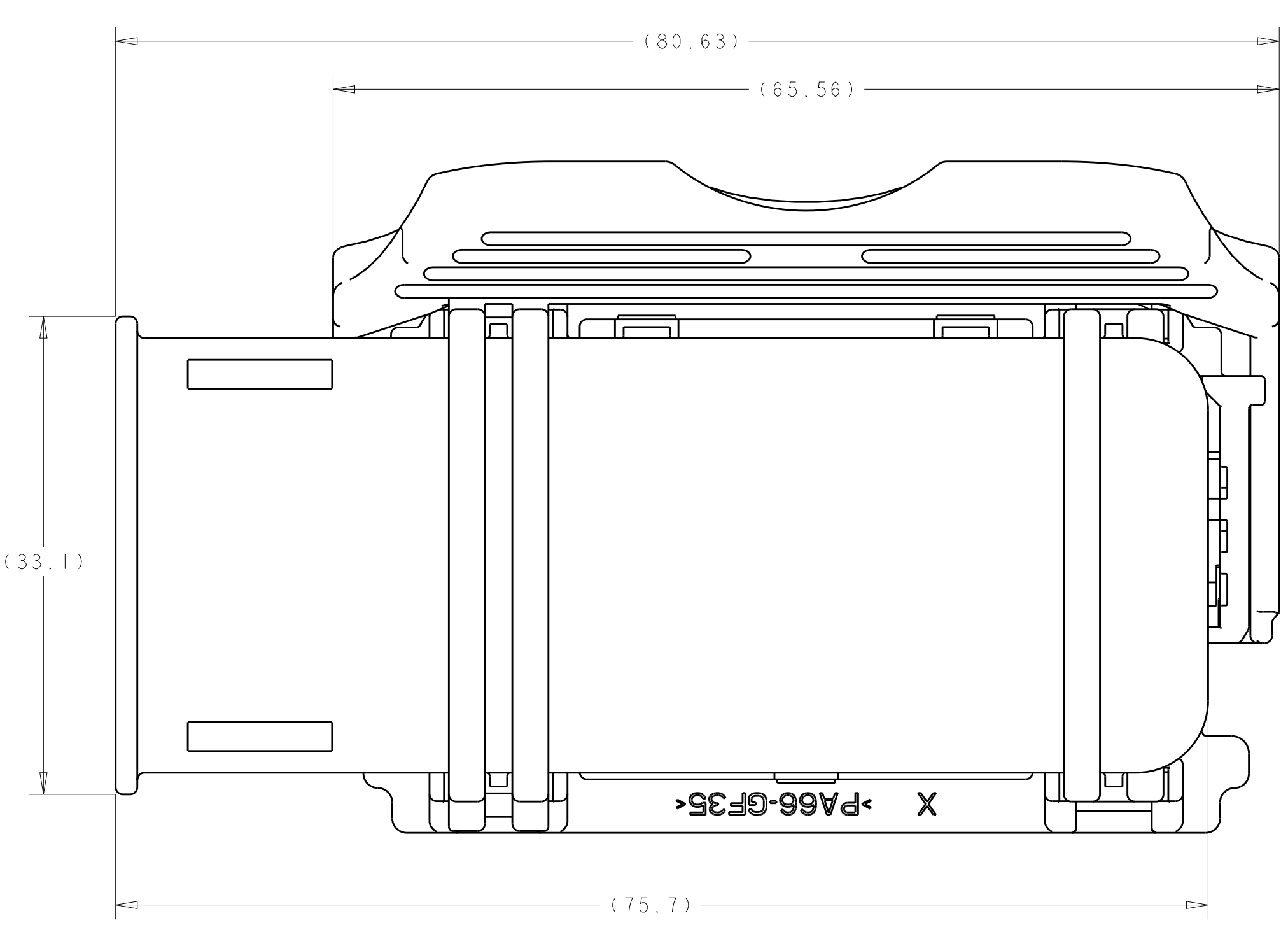
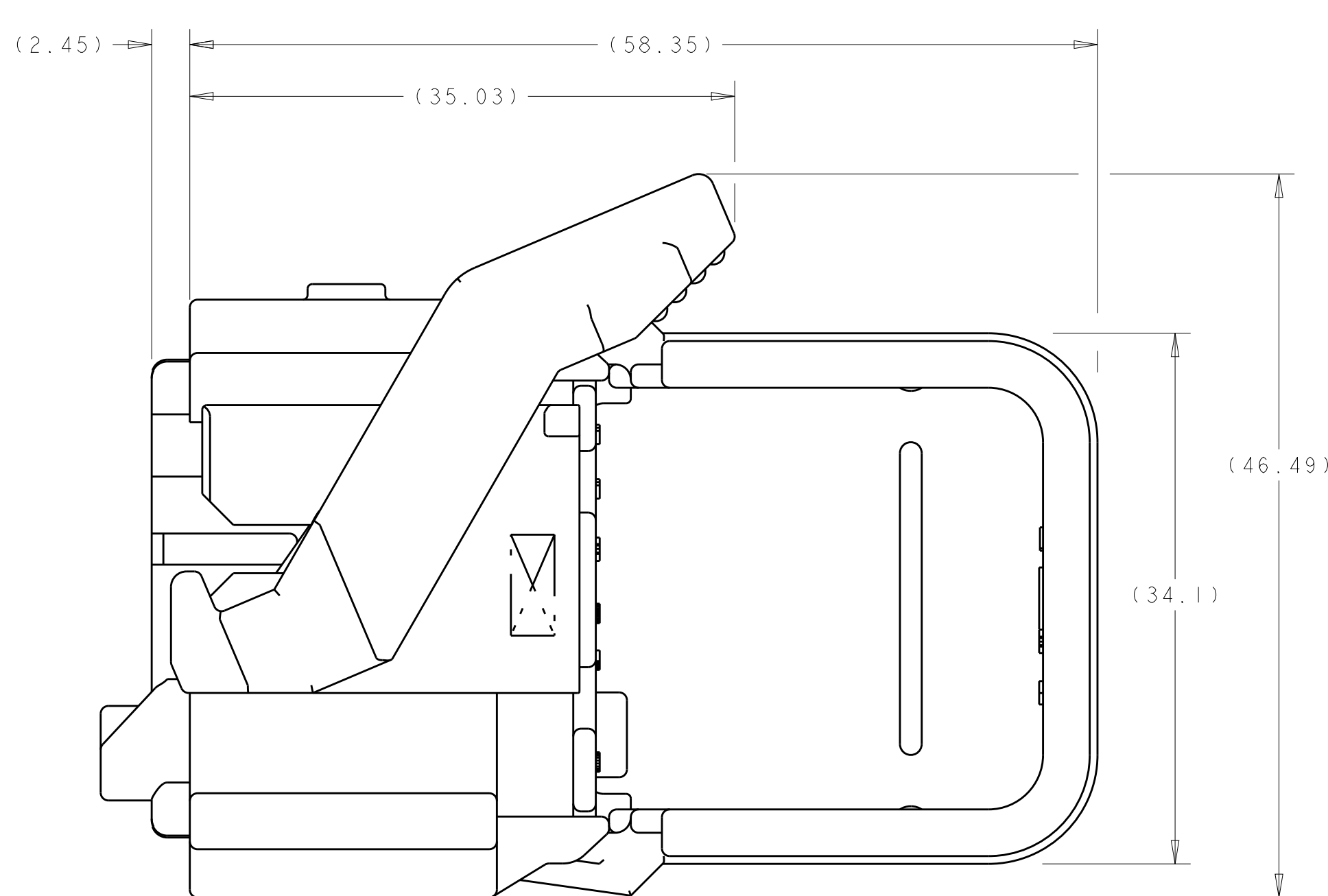

OPTION #3: SIDE EXIT
(EITHER RIGHT EXIT OR LEFT EXIT)

THIS DRAWING IS A CONTROLLED DOCUMENT. DATE: 31 AUG 2006. FOR: M. FORLIS. CHK: J. VALASKI. APPD: W. RAY. PRODUCT SPEC: 74 WAY, SEALED, HYBRID, FEMALE. APPLICATION SPEC: CUSTOMER DRAWING. MATERIAL: PA66-GF35. FINISH: BLACK. WEIGHT: .147. SCALE: 3:1. SHEET 3 OF 3. REV: A5.

STE TE Connectivity