

CIRCUIT SIZE	DIM. A	DIM. B	DIM. C	DIM. D
20	13.90 .547	9.00 .354	12.58 .495	12.40 .488
30	18.90 .744	14.00 .551	17.58 .692	17.40 .685
40	23.90 .941	19.00 .748	22.58 .889	22.40 .882
50	28.90 1.138	24.00 .945	27.58 1.086	27.40 1.079
60	33.90 1.335	29.00 1.142	32.58 1.283	32.40 1.276
64	35.90 1.413	31.00 1.220	34.58 1.361	34.40 1.354
70	38.90 1.531	34.00 1.339	37.58 1.480	37.40 1.472
80	43.90 1.728	39.00 1.535	42.58 1.676	42.40 1.669
84	45.90 1.807	41.00 1.614	44.58 1.755	44.40 1.748
90	48.90 1.925	44.00 1.732	47.58 1.873	47.40 1.866
100	53.90 2.122	49.00 1.929	52.58 2.070	52.40 2.063
110	58.90 2.319	54.00 2.126	57.58 2.267	57.40 2.260
120	63.90 2.516	59.00 2.323	62.58 2.464	62.40 2.457

NOTES:

- HOUSING MATERIAL: LIQUID CRYSTAL POLYMER (LCP) GLASS FILLED.; UL RATING: 94V-0; COLOR: WHITE OR BLACK
TERMINAL MATERIAL: PHOSPHOR BRONZE; 0.205/.0080 THICK
VACUUM CAP MATERIAL: STAINLESS STEEL; 0.255/.0100 THICK
- PLATING FINISHES: SEE SHEET 2
- PRODUCT SPECIFICATION: PS-71436-999
- PACKAGING SPECIFICATIONS: REFER TO CHART ON SHEET 2.
- MATES WITH: 71439 SERIES. SEE SHEET 2 FOR MATING VIEW AND STACK HEIGHT.
- PEGS ARE OPTIONAL. REFER TO CHART ON SHEET 2.
- VACUUM PICK & PLACE CAP IS OPTIONAL. REFER TO CHART ON SHEET 2.
- THIS PART CONFORMS TO EIA STANDARD 700 AAAB FOR 1.0mm TWO-PART CONNECTORS FOR USE WITH PARALLEL PRINTED BOARDS.
- COPLANARITY OF SMT TAILS: 0.10/.004 MAX.
- 64-CIRCUIT PLUG ASSEMBLY WITH PEGS AND VACUUM CAP SHOWN FOR ILLUSTRATION PURPOSES ONLY.
- DIMENSIONS ARE IN mm/IN. INCH DIMENSIONS SHOWN FOR REFERENCE ONLY.
- ASSEMBLY TO HAVE DATE CODE: XX XX
WEEK _____ YEAR

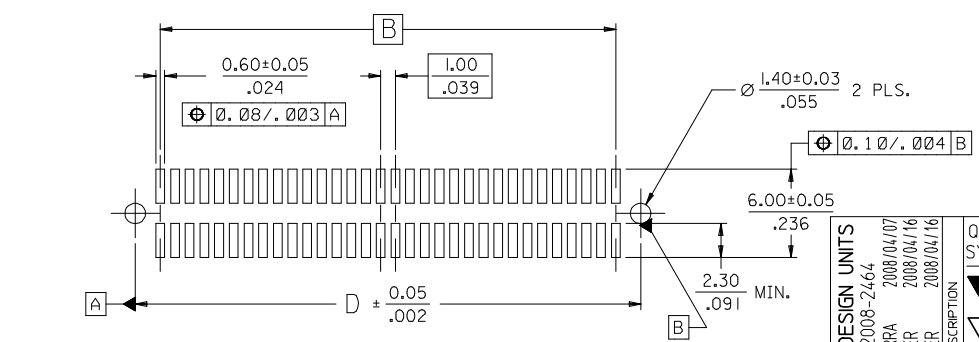
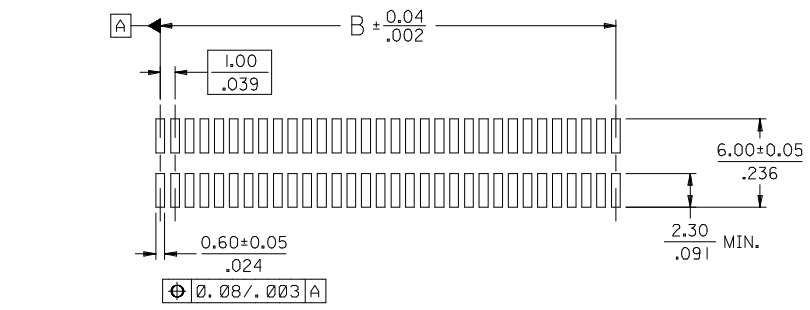

**RECOMMENDED PCB LAYOUT
(WITH AND WITHOUT PEGS)**
RECOMMENDED PCB THICKNESS: 1.00±0.10/.039±.004 MIN.

CORRECT DESIGN UNITS EC NO: UCP2008-2464 DRAWN: MSIBARRA 2008/04/07 CHKD: BBARKER 2008/04/16 APPR: SMILLER 2008/04/16	QUALITY SYMBOLS	GENERAL TOLERANCES (UNLESS SPECIFIED)	DIMENSION STYLE	SCALE	DESIGN UNITS	THIRD ANGLE PROJECTION	
	▽=0	mm INCH	MM/IN	4:1	METRIC		
	▽=0	4 PLACES ± --- ± --- 3 PLACES ± --- ± .005 2 PLACES ± 0.13 ± .01 1 PLACE ± 0.25 ± ---	DRAWN BY DATE RKADAMS 08/18/2004	TITLE	SALES ASSY, 1.0MM BOARD-TO-BOARD PLUG 4.30/169 STACK HEIGHT		
	ANGULAR ±1/2°	CHECKED BY DATE BBARKER 08/18/2004	APPROVED BY DATE SMILLER 08/18/2004	MOLEX INCORPORATED			
REV	DRAFT WHERE APPLICABLE MUST REMAIN WITHIN DIMENSIONS	MATERIAL NO.	DOCUMENT NO.	SHEET NO.			
		SEE TABLE	SD-71436-003	1 OF 2			
		THIS DRAWING CONTAINS INFORMATION THAT IS PROPRIETARY TO MOLEX INCORPORATED AND SHOULD NOT BE USED WITHOUT WRITTEN PERMISSION					

2	C
1	E
SHT	REV

WHITE (NATURAL) MATERIAL

CIRCUIT SIZE	PLUG ASSEMBLY ITEM NUMBER	PEGS	CONTACT PLATING (SEE PLATING NOTES)	PICK & PLACE CAP	PACKAGING SPEC. NUMBER	PACKAGING TYPE
64	71436-2146	YES	30 GOLD	NO	PK-70873-0607	TUBE
64	71436-2346	YES	30 GOLD	YES	PK-70873-0607	TUBE
64	71436-2446	YES	30 GOLD	YES	PK-70873-063	TAPE & REEL
64		NO	30 GOLD	NO	PK-70873-0606	TUBE
64		NO	30 GOLD	YES	PK-70873-0606	TUBE
64	71436-2846	NO	30 GOLD	YES	PK-70873-063	TAPE & REEL
64		NO	50 GOLD	YES	PK-70873-063	TAPE & REEL

PLATING NOTES:

30 GOLD: SELECTIVE GOLD (Au) IN THE CONTACT AREA;
 THICKNESS = 0.76 MICROMETERS (30 MICROINCHES) MINIMUM;
 SELECTIVE TIN (Sn) IN THE PC TAIL AREA;
 THICKNESS = 1.88 MICROMETERS (75 MICROINCHES) MINIMUM;
 NICKEL UNDERPLATE OVERALL.

50 GOLD: SELECTIVE GOLD (Au) IN THE CONTACT AREA;
 THICKNESS = 1.27 MICROMETERS (50 MICROINCHES) MINIMUM;
 SELECTIVE TIN (Sn) IN THE PC TAIL AREA;
 THICKNESS = 1.88 MICROMETERS (75 MICROINCHES) MINIMUM;
 NICKEL UNDERPLATE OVERALL.

BLACK MATERIAL WITH PICK & PLACE CAP

CIRCUIT SIZE	PLUG ASSEMBLY ITEM NUMBER	PEGS	CONTACT PLATING (SEE NOTES PAGE2)	PICK & PLACE CAP	PACKAGING SPEC. NUMBER	PACKAGING TYPE
64		NO	30 GOLD	YES	PK-70873-0634	TAPE & REEL

RECOMMENDED PLUG/RECEPTACLE COMBINATION FOR MATED STACK HEIGHT PER EIA STANDARD 700 AAAB

MATED STACK HEIGHT	RECEPTACLE HEIGHT	RECEPTACLE SERIES NO.	PLUG HEIGHT	PLUG SERIES NO.
10.00/.394	5.30/.209	71439-0***	4.30/.169	71436-2***
12.00/.472	7.30/.287	71439-1***	4.30/.169	71436-2***
13.00/.512	8.30/.327	71439-2***	4.30/.169	71436-2***
15.00/.591	10.30/.406	71439-3***	4.30/.169	71436-2***

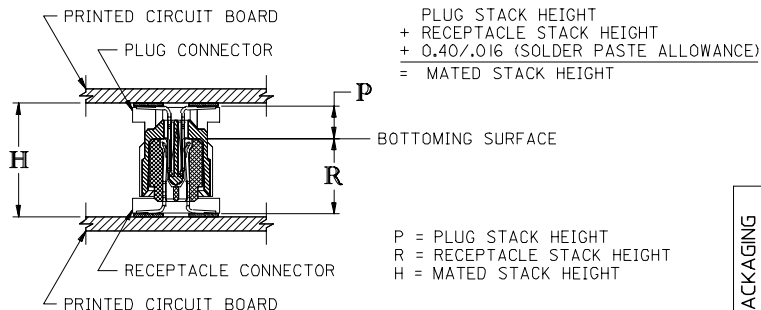

MODIFY PACKAGING EC NO: UCP2006-2840 DRWN:MS/BARRA 2006/06/12 CHKD:BBARKER 2006/06/12 APPR:SMILLER 2006/06/12 REVISION	QUALITY SYMBOLS	GENERAL TOLERANCES (UNLESS SPECIFIED)	DIMENSION STYLE	SCALE	DESIGN UNITS	THIRD ANGLE PROJECTION
	$\nabla=0$ $\nabla=0$	mm INCH 4 PLACES ± --- ± --- 3 PLACES ± --- ±.005 2 PLACES ±0.13 ±.01 1 PLACE ±0.25 ± --- ANGULAR ±1/2°	MM/IN	---	INCH	DRAWN BY DATE RKADAMS 08/18/2004 CHECKED BY DATE BBARKER 08/18/2004 APPROVED BY DATE SMILLER 08/18/2004
		DRAFT WHERE APPLICABLE MUST REMAIN WITHIN DIMENSIONS	SEE TABLE	SALES ASSY, 10MM BOARD-TO-BOARD PLUG 4.30/.169 STACK HEIGHT MOLEX INCORPORATED		MATERIAL NO. SD-71436-003
				THIS DRAWING CONTAINS INFORMATION THAT IS PROPRIETARY TO MOLEX INCORPORATED AND SHOULD NOT BE USED WITHOUT WRITTEN PERMISSION		SHEET NO. 2 OF 2