

Type-C Port Controller (TCPC) with IEC-ESD Protection on SBU/CC/DP/DM, USB2.0 Switch, Charging Port Controller and Power-Path Control

General Description

The RT1718S is a highly integrated TCPC controller which includes IEC-61000-4-2 ESD protection cell for CC/SBU/DP/DM. The RT1718S integrates several high voltage protection switch of SBU1/SBU2/DP/DM from high voltage VBUS touching the adjacent pins. The AMR of SBU OVP switch is 24V. High Voltage USB 2.0 Switches also support HV DCP and fast charging protocols.

The RT1718S can control VBUS sink and source path by internal Charge pump for NMOS FET and GPIO for PMOS FET. The GPIOs of RT1718S can be also configured to control system block such as USB3.0 to DP Mux for alternated mode usage.

VCONN Switch with OVP/OCP/RVP/UVS protection is also integrated. The RPD_CC1/CC2 are the dead battery mode Rd pin which are independent from CC1/CC2 for each customer system flexibility.

The RT1718S is available in a WQFN-32L 4x4 package.

Ordering Information

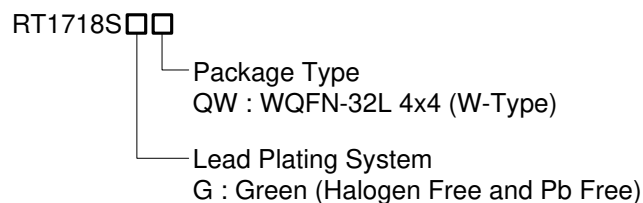

Note :

Richtek products are :

- ▶ RoHS compliant and compatible with the current requirements of IPC/JEDEC J-STD-020.
- ▶ Suitable for use in SnPb or Pb-free soldering processes.

Features

- Supporting TCPC 1.2 Version
- Low Voltage DRP (2V)
- CC AMR = 24V, Meet IEC-61000-4-2 ESD Protection
- SBU AMR = 24V, Meet IEC-61000-4-2 ESD Protection with OVP Switch Function
- DP/DM USB2.0 Switch with 3dB BW of 800MHz & High Voltage of 21V Protection and Meet IEC-61000-4-2 ESD Protection
- DP/DM Supports Charging Port Controller for SINK and SRC Port (USB PD 3.0, BC1.2, Other Proprietary Protocols)
- Control External NMOS and PMOS for Power Path
- Power Path with VBUS OCP of SRC Mode
- 3-GPIO are Configurable
- 4-State ADDR pin for Multiport Application
- Dead Battery Mode Rd is on RPD_CC1/CC2
- Powered by VBUS and VCC

Applications

- Desktop, Notebook, PC
- USB Hub/Dongle
- TV/Monitor
- Server/Data Center

Marking Information

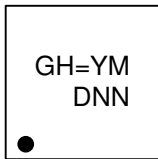

GH= : Product Code
YMDNN : Date Code

Pin Configuration

(TOP VIEW)

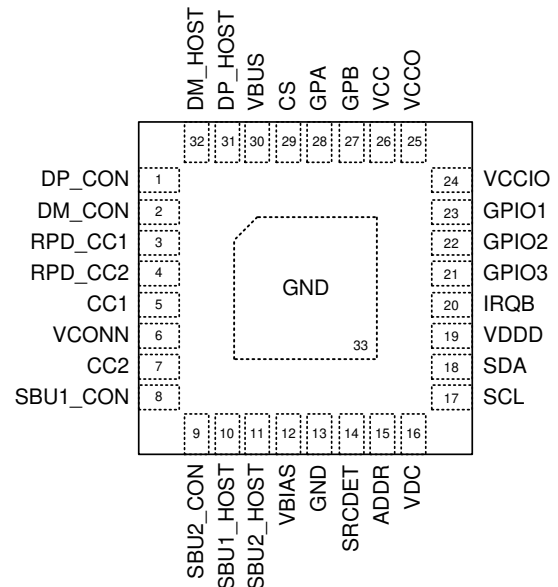

WQFN-32L 4x4

Functional Pin Description

Pin No.	Pin Name	Pin Function
1	DP_CON	Type-C connector side DP. Connect to DP of Type-C USB connector.
2	DM_CON	Type-C connector side DM. Connect to DM of Type-C USB connector.
3	RPD_CC1	Short to CC1 with 200Ω resistor if dead battery resistors are needed.
4	RPD_CC2	Short to CC2 with 200Ω resistor if dead battery resistors are needed.
5	CC1	Type-C connector configuration channel pin. Initially used to determine when an attachment has occurred and what the orientation detected. Put a 560pF (0603/50V) capacitor.
6	VCONN	Regulated power input pin to output VCONN through CC pin for Type-C full-featured cables and other accessories. If the type c port does not support VCONN power, connect this pin to GND with 10kΩ resistor.
7	CC2	Type-C connector configuration channel pin. Initially used to determine when an attachment has occurred and what the orientation detected. Put a 560pF (0603/50V) capacitor.
8	SBU1_CON	Type-C connector side SBU1. Connect to SBU1 of Type-C USB connector.
9	SBU2_CON	Type-C connector side SBU2. Connect to SBU2 of Type-C USB connector.
10	SBU1_HOST	System side SBU1. Connect to SBU1 of System controller.
11	SBU2_HOST	System side SBU2. Connect to SBU2 of System controller.
12	VBIAS	Put a 0.1μF (0402/50V) capacitor. This pin cannot drive external load.
13, 33 (Exposed Pad)	GND (Exposed Pad)	Ground. The exposed pad must be connected to GND and be well soldered to a large copper PCB for maximum power dissipation.

Pin No.	Pin Name	Pin Function
14	SRCDDET	Setting pin for detecting RP level without VCC power. Detect the RP level to control the power path by GPIO3.
15	ADDR	Address selection node when used with multiple Type-C ports.
16	VDC	Barrel jack DC power input detection pin.
17	SCL	I ² C interface serial clock input. Open-drain. An external pull-up resistor is required.
18	SDA	I ² C interface serial data input/output. Open-drain. An external pull-up resistor is required.
19	VDDD	Put a 1μF capacitor. This pin cannot drive external load.
20	IRQB	Interrupt output, active-low open-drain, to prompt the processor to read the registers.
21	GPIO3	Configurable GPIO3 with open-drain or push-pull type, used as switch control, DC-DC enable, audio enable, and accessory unit control.
22	GPIO2	Configurable GPIO2 with open-drain or push-pull type, used as switch control, DC-DC enable, audio enable, and accessory unit control.
23	GPIO1	Configurable GPIO1 with open-drain or push-pull type, used as switch control, DC-DC enable, audio enable, and accessory unit control.
24	VCCIO	Power input for GPIO1/2/3 application.
25	VCCO	Put a 1μF capacitor. This pin cannot drive external load.
26	VCC	Main power input for the RT1718S.
27	GPB	High voltage gate driver B, which may be used to drive an NMOS/PMOS power switch. This pin is connected to the gate of the power switch. (Related to VBUS).
28	GPA	High voltage gate driver A, which may be used to drive an NMOS/PMOS power switch. This pin is connected to the gate of the power switch. (Related to VBUS).
29	CS	VBUS current sense input. Please series 3.3Ω between current sensing resistor and CS pin. Please put a 0.1μF capacitor between CS pin and VBUS pin.
30	VBUS	VBUS input for OCP/OVP/RCP detection and power input for VBUS to 3.3V regulator.
31	DP_HOST	System side DP_HOST. Connect to DP of system controller.
32	DM_HOST	System side DM_HOST. Connect to DM of system controller.

The RT1718S in Sink Application (Sink Only Port)

R12, R13 and C10 are for soft-on of Q5 and Q6. The values depend on the sink path for system.

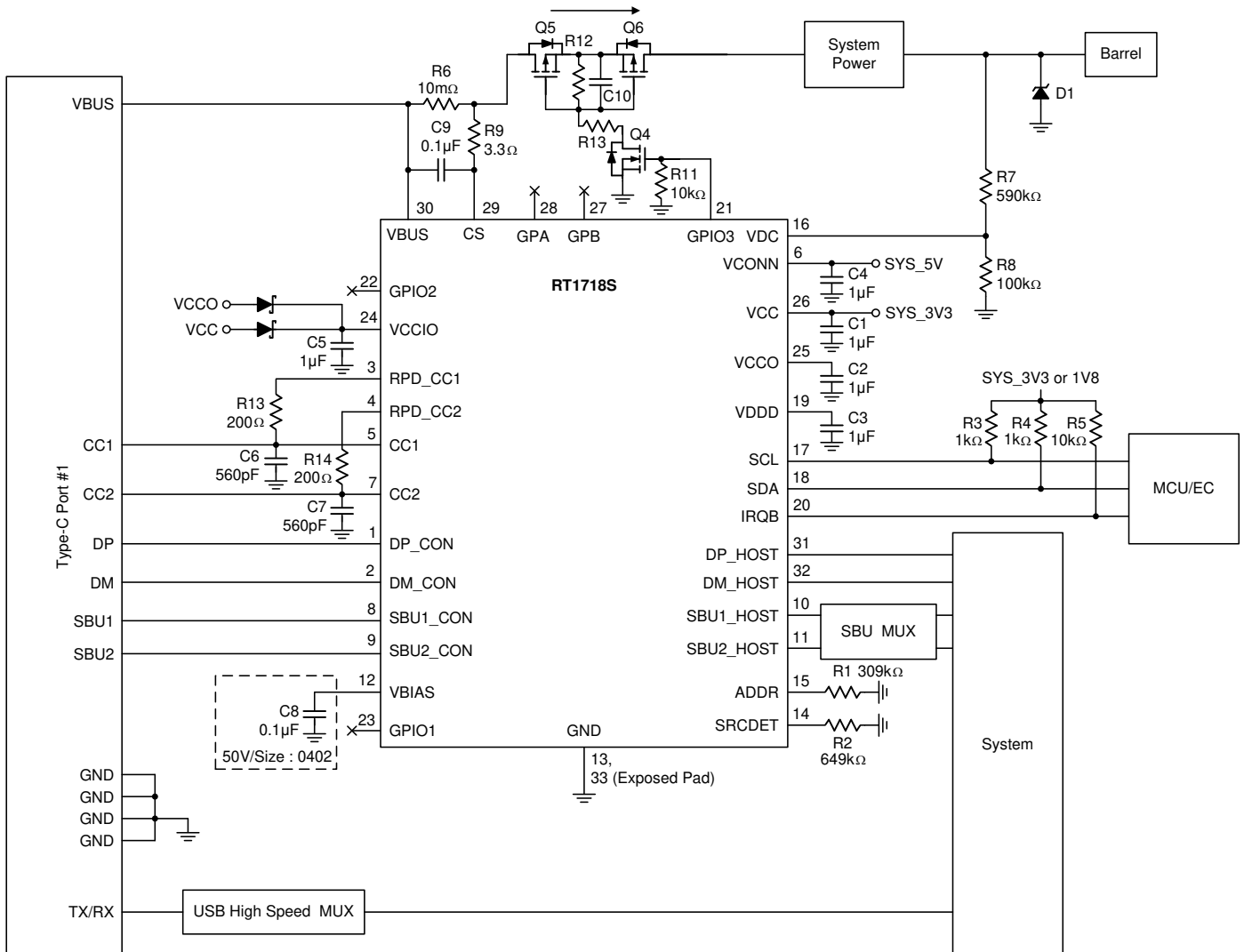

The RT1718S in DRP Application (DRP Port, Source 5V to 20V Output)

R12, R13, C10 are for soft-on of Q5 and Q6. The values depend on the sink path for system.

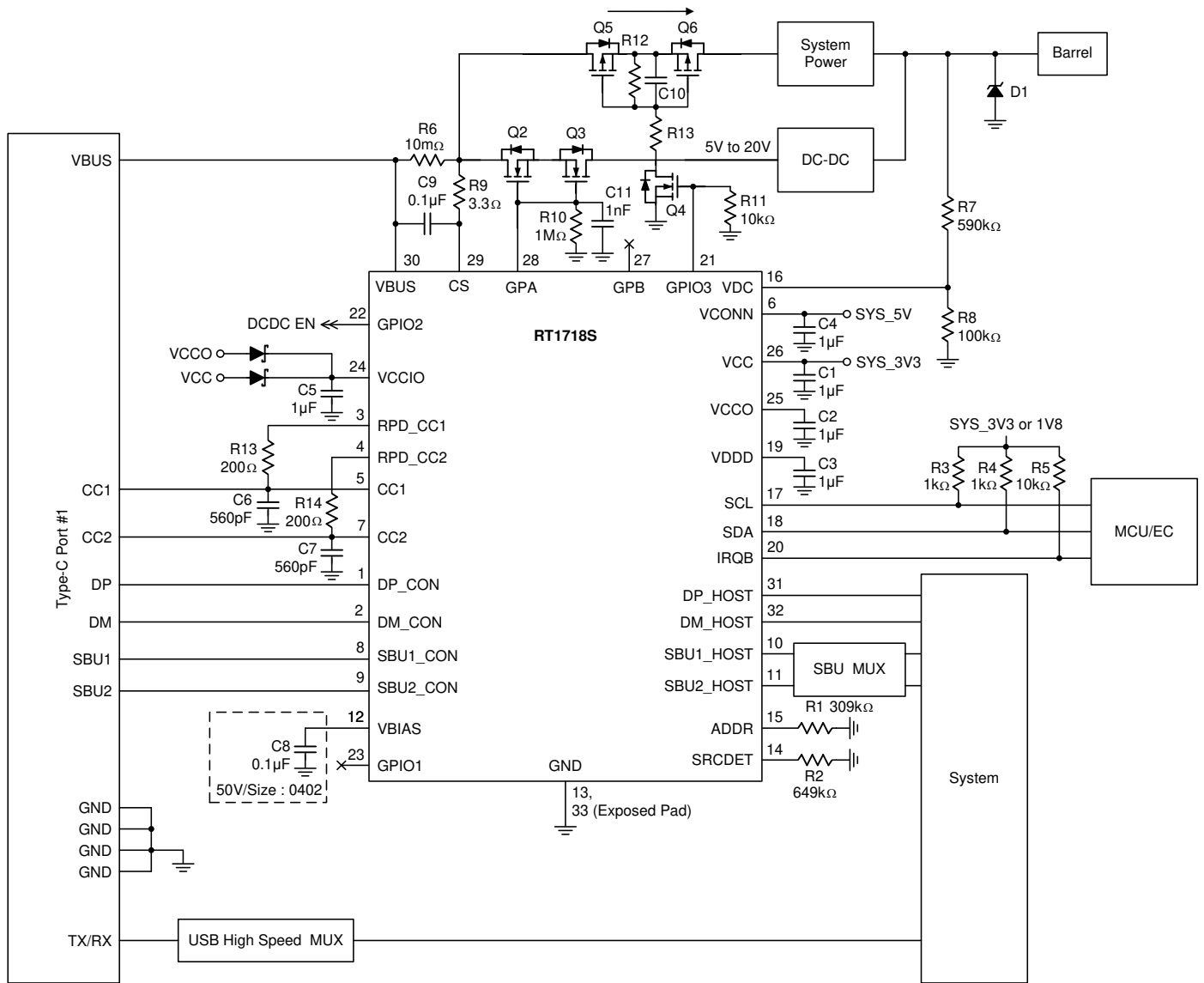

The followings are the recommended components information.

Pin	Part Number	Description	Package	Manufacturer
VBIAS	0402B104K500CT	0.1 μ F/50V/X7R	0402	Walsin
Between VBUS and CS (R6)	RTT25R010FTE	RES SMD 0.01 Ω 1% 1W 2512	2512	RALEC

Functional Block Diagram

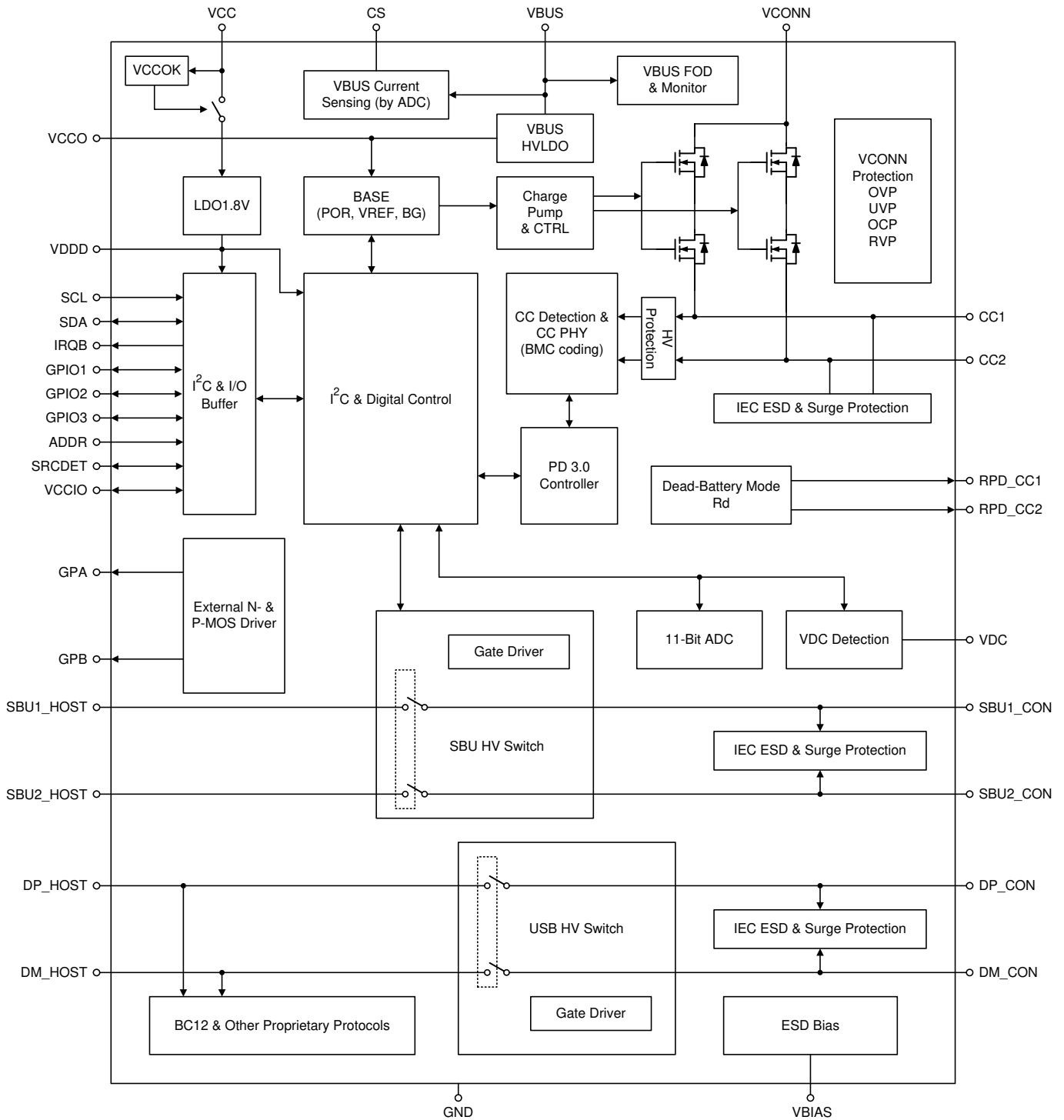

Absolute Maximum Ratings (Note 1)

• VBUS, CS, GPA, GPB	-----	-0.3V to 28V
• CC1, CC2, RPD_CC1, RPD_CC2, VBIAS		
SBU1_CON, SBU2_CON, DP_CON, DM_CON	-----	-0.3V to 24V
• SBU1_HOST, SBU2_HOST, DP_HOST,		
DM_HOST, VCC, VCCO, VCONN, VCCIO	-----	-0.3V to 6V
• SDA, SCL, IRQB, ADDR, GPIO1, GPIO2, GPIO3, VDC, SRCDET	-----	-0.3V to 6V
• VDDD	-----	-0.3V to 2V
• IGPIO1, IGPIO2, IGPIO3	-----	-20mA to 20mA
• Output Current (DP_CON/DM_CON/DP_HOST/DM_HOST)	-----	-100mA to 100mA
• Output Current (SBU1_CON/SBU2_CON/SBU1_HOST/SBU2_HOST)	-----	-100mA to 100mA
• Power Dissipation, P _D @ T _A = 25°C		
• WQFN-32L 4x4	-----	3.59W
• Package Thermal Resistance (Note 2)		
• WQFN-32L 4x4, θ_{JA}	-----	27.8°C/W
• WQFN-32L 4x4, θ_{JC}	-----	7°C/W
• Lead Temperature (Soldering, 10 sec.)	-----	260°C
• Junction Temperature	-----	150°C
• Storage Temperature Range	-----	-65°C to 150°C
• ESD Susceptibility (Note 3)		
HBM (Human Body Model)	-----	±2kV
DP_CON, DM_CON, CC1, CC2, SBU1_CON, SBU2_CON, VBUS		
(IEC 61000-4-2 Contact Discharge)	-----	±8kV
DP_CON, DM_CON, CC1, CC2, SBU1_CON, SBU2_CON, VBUS		
(IEC 61000-4-2 Air Discharge)	-----	±15kV
DP_CON, DM_CON, CC1, CC2, SBU1_CON, SBU2_CON, VBUS		
(IEC 61000-4-5 Surge)	-----	±28V

Recommended Operating Conditions (Note 4)

• Supply Input Voltage, VCC	-----	2.7V to 5.5V
• VBUS	-----	4V to 22V
• VDC	-----	0V to 5.5V
• VCONN Supply Voltage	-----	2.8V to 5.5V
• VCONN Supply Current	-----	100mA to 800mA
• VCCIO	-----	1.5V to 5.5V
• DP_CON/DM_CON/DP_HOST/DM_HOST	-----	0V to 4V
• SBU1_CON/SBU2_CON/SBU1_HOST/SBU2_HOST	-----	0V to 3.4V
• Ambient Temperature Range	-----	-40°C to 85°C
• Junction Temperature Range	-----	-40°C to 125°C

Electrical Characteristics

(V_{CC} = 2.7V to 5.5V, V_{CC} (Typ.) = 3.3V, T_A = -40°C to 85°C and T_A (Typ.) = 25°C, unless otherwise specified)

Parameter	Symbol	Test Conditions	Min	Typ	Max	Unit
Operation Current						
Shut Down Current		Power on state (DPDM, SBU switched off)	--	15	70	μA
Low Power DRP Mode Current		CC toggle at DRP mode when port is unconnected and waiting for connection	--	20	75	μA
Idle Mode Current when attached as Sink		VCONN off SBUx switch is off DP/DM switch is off (0xF23A = 00h) GPA/B charge pump off (0xEC[1:0] = 00b)	--	185	230	μA
Normal Mode Current when attached as Sink		VCONN off SBUx switch is off DP/DM switch is off (0xF23A = 00h) GPA/B charge pump off (0xEC[1:0] = 00b)	--	640	800	μA
More VCC Consumption when DPDM, SBU1/2 Switches On		SBUx switch is on DP/DM switch is on (0xF23A = CFh)	--	70	120	μA
More VCC Consumption when Charge Pumps of GPA and GPB on		GPA/B charge pump on (0xEC[1:0] = 11b)	--	350	380	μA
More VCC consumption when VBUS measurement of ADC on		VBUS measurement of ADC on (0x1C[6] = 0b)	--	160	230	μA
More VCC consumption when VBUS OCP1 on		VBUS OCP1 on (0x1B[2] = 0b)	--	230	300	μA
More VCC consumption when TX Mode with CC Communication			--	2.2	3.1	mA
VBUS Related Parameters						
VBUS_PRESENT Voltage Threshold Rising	VBUS_PRESENT_R	V _{CC} : 2.7V to 5.5V	3.7	3.8	3.9	V
VBUS_PRESENT Voltage Threshold Falling	VBUS_PRESENT_F	V _{CC} : 2.7V to 5.5V	3.4	3.5	3.6	V
VBUS Vsafe0V Falling	VBUS_Vsafe0V_F	V _{CC} : 2.7V to 5.5V	--	0.42	0.8	V
VBUS Vsafe0V Rising	VBUS_Vsafe0V_R	V _{CC} : 2.7V to 5.5V	0.55	0.62	1	V

Parameter	Symbol	Test Conditions	Min	Typ	Max	Unit
VBUS OVP Variation (at VBUS OVP setting *1.2, ie 0xF213[5:4] = 11b)	VBUS_OVP_VAR	V _{CC} : 2.7V to 5.5V	-10	--	10	%
OVP Response Time on the CC Pins. Time from OVP Asserted Until OVP FETs Turn-Off	VBUS_OVP_tResponse	V _{CC} : 2.7V to 5.5V	--	--	12	μs
VBUS OCP1/2	VBUS_OCP1/2	V _{CC} : 2.7V to 5.5V	0.2	--	12.9	A
VBUS OCP1/2_STEP	VBUS_OCP1/2_STEP	V _{CC} : 2.7V to 5.5V	--	100	--	mA
VBUS_OCP1/2_Accuracy	VBUS_OCP1/2_Accuracy	V _{CC} : 2.7V to 5.5V Tested with 10mΩ current sensing resistor. It is not considered the variation from current sensing resistor. LSB is 33.33mA.	-5	--	5	LSB
VBUS OCP3	VBUS_OCP3		7.25	--	15	A
VBUS_OCP3_Accuracy	VBUS_OCP3_Accuracy	V _{CC} : 2.7V to 5.5V Tested with 10mΩ current sensing resistor. It is not considered the variation from current sensing resistor.	-6	--	6	%
VBUS_OCP3_Time	VBUS_OCP3_time		--	--	12	μs
VBUS RCP1/2	VBUS_RCP1/2	V _{CC} : 2.7V to 5.5V	0.2	--	12.9	A
VBUS RCP1/2_STEP	VBUS_RCP1/2_STEP	V _{CC} : 2.7V to 5.5V	--	100	--	mA
VBUS_RCP1/2_Accuracy	VBUS_RCP1/2_Accuracy	V _{CC} : 2.7V to 5.5V Tested with 10mΩ current sensing resistor. It is not considered the variation from current sensing resistor. LSB is 33.33mA.	-5	--	5	LSB
VBUS RCP3	VBUS_RCP3		7.25	--	15	A
VBUS_RCP3_Accuracy	VBUS_RCP3_Accuracy		-20	--	20	%
VBUS_RCP3_Time	VBUS_RCP3_time		--	--	12	μs
VBUS Foreign Object Detection						
FOD Pull-Up Open Voltage	VFOD_LDO		1.9	2	2.1	V
FOD OV Level	VFOD_OV		2.16	2.4	2.64	V
FOD Pre-Charge Current	IFOD_pre		18	20	22	mA
FOD Sense Current1	IFOD_sense1		9.5	10	10.5	mA
FOD Sense Current2	IFOD_sense2		4.5	5	5.5	mA
Sense Resistor Level	RFOD_sense		-10	--	10	%

Parameter	Symbol	Test Conditions	Min	Typ	Max	Unit
Type-C Port Control						
DFP 80 μ A CC Current	INOR_RP80 μ A		64	80	96	μ A
DFP 180 μ A CC Current	INOR_RP180 μ A		166	180	194	μ A
DFP 330 μ A CC Current	INOR_RP330 μ A		304	330	356	μ A
UFP Rd	Rd		4.59	5.1	5.61	k Ω
UFP Pull-Down Voltage in Dead Battery under DFP 80 μ A	V _{DB_80μA}		0.25	--	1.5	V
UFP Pull-Down Voltage in Dead Battery under DFP 180 μ A	V _{DB_180μA}		0.45	--	1.5	V
UFP Pull-Down Voltage in Dead Battery under DFP 330 μ A	V _{DB_330μA}		0.85	--	2.45	V
CC Communication						
Bit Rate	fBitRate_PD		270	300	330	Kbps
Maximum difference between the bit-rate during the part of the packet following the Preamble and the reference bit-rate	pBitRate		--	--	0.25	%
Time from the end of last bit of a Frame until the start of the first bit of the next Preamble	tInterFrameGap		25	--	--	μ s
Time before the start of the first bit of the Preamble when the transmitter shall start driving the line	tStartDrive		-1	--	1	μ s
Time to cease driving the line after the end of the last bit of the Frame	tEndDriveBMC		--	--	23	μ s
Fall Time	tFall		300	--	--	ns
Time to cease driving the line after the final high-to-low transition	tHoldLowBMC		1	--	--	μ s
Rise Time	tRise		300	--	--	ns
Voltage Swing	vSwing		1.05	1.125	1.2	V
Transmitter Output Impedance	zDriver		33	50	75	Ω

Parameter	Symbol	Test Conditions	Min	Typ	Max	Unit
BMC Receiver Input Impedance	zBmcRx		1	--	--	M Ω
VCONN Switch						
VCONN OVP	VCONN_OVP	The rising voltage threshold at the CC pin which outputs Vconn.	5.55	--	6	V
Released VCONN OVP	VCONN_OVP_Released	The falling voltage threshold at the CC pin which outputs Vconn.	5.5	--	5.95	V
VCONN Under-Voltage Threshold	VCONN_UVT		2.4	2.7	3	V
Hysteresis on VCONN UV	VCONN_UVT_HYS		50	100	150	mV
VCONN RVP1	VCONN_RVP1		0.1	0.3	0.55	V
VCONN RVP2	VCONN_RVP2		0.3	0.5	0.85	V
VCONN OCP Range (Shut Down)	VCONN_OCP_range		100	--	800	mA
VCONN OCP Variation (Shut Down)	VCONN_OCP_variation		-10	--	10	%
Ron for VCONN Switch	VCONN_Ron		--	0.7	1	Ω
SBU Switch						
On Leakage Current of SBU Switch	ION_SBU_CON_3.6V	Vcc = 3.3V SBU_CON = 0V to 3.6V, SBU_HOST is floating, SBU Switch On, measure the current of SBU_CON	-3	--	3	μ A
Off Leakage Current of SBU_CON	IOZ_SBU_CON_3.6V	Vcc = 3.3V SBU_CON = 0V to 3.6V, SBU_HOST is floating, SBU Switch Off, measure the current of SBU_CON	-3	--	3	μ A
Off Leakage Current of SBU_CON	IOZ_SBU_CON_24V	Vcc = 3.3V SBU_CON = 24V, SBU_HOST is 0V, SBU Switch OVP, measure the current of SBU_CON	--	--	800	μ A
Power-Off Leakage Current SBU_CON	IOFF_SBU_CON_3.6V	Vcc = 0V SBU_CON = 0V to 3.6V, SBU_HOST is floating, measure the current of SBU_CON	-3	--	3	μ A
On Leakage Current of SBU_HSOT	ION_SBU_HOST_3.6V	Vcc = 3.3V SBU_HOST = 0V to 3.6V, SBU_CON is floating, SBU Switch On, measure the current of SBU_HOST	-3	--	3	μ A
Off Leakage of SBU_HOST	IOZ_SBU_HOST_3.6V	Vcc = 3.3V SBU_HOST = 0V to 3.6V, SBU_CON is floating, SBU Switch Off, measure the current of SBU_HOST	-3	--	3	μ A

Parameter	Symbol	Test Conditions	Min	Typ	Max	Unit
Off Leakage Current of SBU_CON to SBU_HSOT	I _{OFF_SBU_CON_24V} to SBU_HOST	V _{CC} = 0V or 3.3V SBU_CON = 24 V SBU_HOST pins are set to 0 V, SBU Switch OVP, measure leakage out of SBU_HOST pins	-1	--	1	μA
SBU Input OVP Lockout 4.5V	V _{OV_SBU_TRIP_4V5}	V _{CC} = 3.3V, SBU_CON rises from 4V until SBU_HOST goes from H to L	4.4	4.5	4.6	V
SBU Input OVP Lockout 3.8V	V _{OV_SBU_TRIP_3V8}	V _{CC} = 3.3V, SBU_CON rises from 3.3V until SBU_HOST goes from H to L	3.7	3.8	3.9	V
SBU Input OVP Lockout 3.7V	V _{OV_SBU_TRIP_3V7}	V _{CC} = 3.3V, SBU_CON rises from 3.3V until SBU_HOST goes from H to L	3.6	3.7	3.8	V
SBU Input OVP Lockout 3.6V	V _{OV_SBU_TRIP_3V6}	V _{CC} = 3.3V, SBU_CON rises from 3.3V until SBU_HOST goes from H to L	3.5	3.6	3.7	V
SBU Input OVP Hysteresis	V _{OV_SBU_HYS}	V _{CC} = 3.3V, SBU_CON falls from 5V until SBU_HOST goes from L to H	35	60	85	mV
SBU Pins OVP Response Time	t _{OV_P_SBU}	V _{CC} = 3.3V, Hot-Plug with 1m cable voltage SBU_CON = 0 to 24V, 40V/μs. Put a 100nF cap and 40W in series to GND on SBU_HOST. Time from OVP trip voltage predicated to switches to turn OFF	--	60	120	ns
SBU_HOST Switch On Resistance	R _{ON_SBU}	V _{CC} = 3.3V, V _{SBU_CON} = 0V to 3.6 V, I _{sw} = 30mA	--	6	9	Ω
SBU On Resistance Flatness	R _{ON(FLAT)_SBU}	V _{CC} = 3.3V, Sweep SBU_CON voltage between 0 V and 3.6V. -40°C ≤ T _J ≤ 85°C	--	--	0.15	Ω
SBU_HOST Switch Turn-On Time	t _{ON_SBU}	V _{CC} = 3.3V, SBU_CON = 2.5V, Put a 50W in series to GND on SBU_HOST. Time from I ² C turn on command trip SBU_HOST voltage to 90% of SBU_CON	150	250	400	μs
SBU_HOST Switch Turn-Off Time	t _{OFF_SBU}	V _{CC} = 3.3V, SBU_CON = 2.5 V, Put a 50W in series to GND on SBU_HOST. Time from I ² C turn off command trip SBU_HOST voltage to 10% of SBU_CON	--	15	20	μs
-3dB Bandwidth	BW _{SBU}	Single ended, 50W terminal, V _{SBU_CON} = 0.1V to 1.2V	200	--	--	MHz

Parameter	Symbol	Test Conditions	Min	Typ	Max	Unit
Crosstalk for SBU	Xtalk_SBU	Swing 1VPP at 1MHz, measure the SBU_HOST1 to SBU_CON2 or SBU_HOST2 to SBU_CON1 with 50W terminal	-51	-80	--	dB
Short-to-VBUS System-Side Clamping Voltage on the SBU_HOST Pins	VSTBUS_SBUHOST_CLAMP	VCC = 3.3V, Hot-Plug with 1m cable voltage SBU_CON = 0 to 24 V, 40V/us. Put a 100nF cap and 40W in series to GND on SBU_HOST.	--	7	8.5	V
DP/DM HV Switch						
On Leakage Current of USB Switch	ION_CON_USB_3.6V	VCC = 3.3V DP_CON, DM_CON = 0V to 3.6V, DP_HOST, DM_HOST is floating, DP, DM Switch On, measure the current of DP_CON, DM_CON	-3	--	3	μA
Off Leakage Current of DP_CON and DM_CON	IOZ_CON_USB_3.6V	VCC = 3.3V DP_CON, DM_CON = 0V to 3.6V, DP_HOST, DM_HOST is floating, DP,DM Switch Off, measure the current of DP_CON, DM_CON	-3	--	3	μA
Off Leakage Current of DP_CON and DM_CON	IOZ_CON_USB_24V	VCC = 3.3V DP_CON, DM_CON = 24V, DP_HOST, DM_HOS is 0V, DP, DM Switch OVP, measure the current of DP_CON, DM_CON	--	--	800	μA
Power-Off Leakage Current of DP_CON and DM_CON	IOFF_CON_USB_3.6V	VCC = 0V DP_CON, DM_CON = 0V to 3.6V, DP_HOST, DM_HOST is floating, measure the current of SBU_CON	-3	--	3	μA
On Leakage Current of DP_HOST and DM_HOST	ION_USB_HOST_3.6V	VCC = 3.3V DP_HOST, DM_HOST = 0V to 3.6V, DP_CON, DM_CON is floating, SBU Switch On, measure the current of DP_HOST, DM_HOST	-3	--	3	μA
Off Leakage Current of DP_HOST and DM_HOST	IOZ_USB_HOST_3.6V	VCC = 3.3V DP_HOST, DM_HOST = 0V to 3.6V, DP_CON, DM_CON is floating, SBU Switch Off, measure the current of DP_HOST, DM_HOST	-3	--	3	μA
Off Leakage Current of CON_USB to USB_HSOT	IOFF_CON_USB_24V to USB_HOST	VCC = 0V or 3.3V DP_CON, DM_CON = 24V DP_HOST, DM_HOST pins are set to 0 V, SBU Switch OVP, measure leakage out of DP_HOST, DM_HOST pins	-1	--	1	μA

Parameter	Symbol	Test Conditions	Min	Typ	Max	Unit
USB Input OVP Lockout	V _{OV_USB_TRIP}	V _{CC} = 3.3V, DP_CON, DM_CON rises from 4V until DP_HOST, DM_HOST goes from H to L	4.35	4.5	4.7	V
USB Input OVP Hysteresis	V _{OV_USB_HYS}	V _{CC} = 3.3V, DP_CON, DM_CON falls from 5V until DP_HOST, DM_HOST goes from L to H	35	60	85	mV
DP and DM Pins OVP Response Time	t _{OV_USB}	V _{CC} = 3.3V, Hot-Plug with 1m cable voltage DP_CON, DM_CON = 0 to 24V, 40V/μs. Put a 100nF cap and 40W in series to GND on DP_HOST, DM_HOST. Time from OVP trip voltage predicated to switches to turn OFF	--	60	120	ns
USB Switch On Resistance	R _{ON_USB}	V _{CC} = 3.3V, VDP_CON, VDM_CON = 0V to 3.6V, I _{sw} = 8mA	--	6	9	Ω
USB On Resistance Flatness	R _{ON(FLAT)_USB}	V _{CC} = 3.3V, Sweep VDP_CON, VDM_CON voltage between 0 V and 3.6V. -40°C ≤ T _J ≤ 85°C	--	--	0.15	Ω
USB Switch Turn-On Time	t _{ON_USB}	V _{CC} = 3.3V, DP_CON, DM_CON = 2.5V, Put a 50W in series to GND on DP_HOST, DM_HOST. Time from I2C turn on command trip DP_HOST, DM_HOST voltage to 90% of SBU_CON	150	250	400	μs
USB Switch Turn-Off Time	t _{OFF_USB}	V _{CC} = 3.3V, DP_CON, DM_CON = 2.5V, Put a 50W in series to GND on DP_HOST, DM_HOST. Time from I2C turn off command trip DP_HOST, DM_HOST voltage to 10% of DP_CON, DM_CON	--	15	20	μs
-3dB Bandwidth for USB	BW _{USB}	Single ended, 50W terminal, VDP_CON, VDM_CON = 0.1V to 1.2V	700	800	--	MHz
Crosstalk for USB	X _{talk_USB}	Swing 1VPP at 1MHz, measure the DP_HOST to DM_CON or DM_HOST to DP_CON with 50W terminal	-51	-80	--	dB
Off Isolation between DP_HSOT, DM_HOST and Com-mon Node Pins	OIRR _{USB}	Test power 0dBm at 1kHz, measure the DP_CON to DP_HOST or DM_CON to DM_HOST with 50ohm terminal	-90	-100	--	dB

Parameter	Symbol	Test Conditions	Min	Typ	Max	Unit
Short-to-VBUS System-Side Clamping VSB_HOST Pins	VSTBUS_USB_HOST_CLAMP	VCC = 3.3V, Hot-Plug with 1m cable voltage DP_CON, DM_CON = 0 to 24V, 40V/μs. Put a 100nF cap and 40W in series to GND on DP_HOST, DM_HOST.	--	7	8.5	V
DP/DM Detection						
DP Source Voltage	VDP_SRC		0.5	0.6	0.7	V
DM Source Voltage	VDM_SRC		0.5	0.6	0.7	V
Data Detect Voltage	VDAT_REF		0.25	0.325	0.4	V
Logic Threshold Voltage	VLGC_CHG		0.8	--	2	V
DP Sink Current	IDP_SINK		50	100	150	μA
DM Sink Current	IDM_SINK		50	100	150	μA
Data Contract Detect Current Source	IDP_SRC		7	10	13	μA
Dedicated Charging Port Resistance Across DP/DM	RDCP_DAT		--	--	200	Ω
DP Pull-Down Resistance	RDP_DWN		14.25	20	24.8	kΩ
DM Pull-Down Resistance	RDM_DWN		14.25	20	24.8	kΩ
DP Source On Time	tDP_SRC_ON		40	64	80	ms
DM Source On Time	tDM_SRC_ON		40	64	80	ms
DCD Timeout	tDCD_TIMEOUT		300	600	900	ms
IRQB Electrical Characteristics						
IRQB Low-Level Output Voltage	VIRQB_OL	IIRQB_OL = 4mA	--	--	0.4	V
GPIO						
GPIO Input Voltage HIGH Level	VGPIO_IH		VCCIO x 0.7	--	--	V
GPIO Input Voltage LOW Level	VGPIO_IL		--	--	VCCIO x 0.3	V
GPIO Output Voltage HIGH Level	VGPIO_OH	IOH = -2mA at Vcc = 3.3V	VCCIO-0.7V	--	--	V
GPIO Output Voltage LOW Level	VGPIO_OL	IOL = 4mA at Vcc = 3.3V	--	--	0.4	V
GPIO Input Hysteresis	VGPIO_IN_HYS		400	800	1200	mV
Pull-Up Resistor when Enabled	RUP		36	--	120	kΩ
Pull-Down Resistor when Enabled	RDOWN		36	--	120	kΩ
Input Leakage Current	IGPIO_IN_Leakage		-1	--	1	μA

Parameter	Symbol	Test Conditions	Min	Typ	Max	Unit
ADC						
ADC Resolution	RES_ADC		--	11	--	Bit
VBUS_DIV Measurement Range	VVBUS_ADC0_RANGE		0	--	25	V
VBUS_DIV Resolution	VVBUS_ADC0_RES		--	12.5	--	mV
VBUS_DIV Accuracy	VVBUS_ADC0_ACC		-50	--	50	mV
VBUS_DIV Measurement Range	VVBUS_ADC1_RANGE		0	--	5	V
VBUS_DIV Resolution	VVBUS_ADC1_RES		--	4	--	mV
VBUS_DIV Accuracy	VVBUS_ADC1_ACC		-20	--	20	mV
CCx Measurement Range	VCCx_ADC_RANGE		0	--	5	V
CCx Resolution	VCCx_ADC_RES		--	4	--	mV
CCx Accuracy	VCCx_ACC		-20	--	20	mV
SBUx Measurement Range	VSBUx_ADC_RANGE		0	--	5	V
SBUx Resolution	VSBUx_ADC_RES		--	4	--	mV
SBUx Accuracy	VSBUx_ACC		-20	--	20	mV
DP/DM Measurement Range	VDP/DM_ADC_RANGE		0	--	5	V
DP/DM Resolution	VDP/DM_ADC_RES		--	4	--	mV
DP/DM Accuracy	VDP/DM_ACC		-20	--	20	mV
GPA and GPB						
GPA/B Output High	VGPA/B Output High	Gate driver voltage at Vbus = 0V	4.4	4.7	5	V
GPA/B Pull-Up 1	IGPA Pull-up_1		40	55	80	μA
GPA/B Pull-Up 2	IGPA Pull-up_2	Time of GPA/B rising from 0V to 8V with VBUS = 5V and capacitance = 1nF at GPA/B.	30	60	90	μs
GPA/B Pull-Down 1	IGPA Pull-down_1		40	55	70	μA
GPA/B Pull-Down 2	IGPA Pull-down_2		200	250	300	μA
GPA/B Pull-Down 3	RGPA Pull-down_3	GPA/B ≤ 2V.	2	5	8	kΩ
GPA/B Pull-Down 4	IGPA Pull-down_4		150	200	250	μA
VDC						
VDC Detect Threshold Rising 2V	VDC 2V_rising		1.93	2.15	2.37	V
VDC Detect Threshold Falling 2V	VDC 2V_falling		1.8	2	2.2	V
VDC Detect Threshold Rising 1.5V	VDC 1.5V_rising		1.485	1.65	1.815	V
VDC Detect Threshold Falling 1.5V	VDC 1.5V_falling		1.35	1.5	1.65	V

Parameter	Symbol	Test Conditions	Min	Typ	Max	Unit
VDC Detect Threshold Rising 0.9V	VDC_0.9V_rising		0.945	1.05	1.155	V
VDC Detect Threshold Falling 0.9V	VDC_0.9V_falling		0.8	0.9	1.0	V
VDC Detect Threshold Rising 0.55V	VDC_0.55V_rising		0.6	0.7	0.8	V
VDC Detect Threshold Falling 0.55V	VDC_0.55V_falling		0.5	0.55	0.6	V
I²C						
I ² C Bus Supply Voltage	I2C_VCC	VCC = 3V to 5.5V	1.8	--	3.6	V
Low-Level Input Voltage	VIL	VCC = 3V to 5.5V	--	--	0.4	V
High-Level Input Voltage	VIH	VCC = 3V to 5.5V	1.26	--	--	V
Low-Level Output Voltage	VOL	VCC = 3V to 5.5V, open-drain	--	--	0.4	V
Input Current each IO Pin	Ii	VCC = 3V to 5.5V 0.1VCC < VI < 0.9VCCMAX	-10	--	10	μA
SCL Clock Frequency	fSCL	VCC = 3V to 5.5V	100	--	3000	kHz
Pulse width of spikes that must be suppressed by the input filter	tSP	VCC = 3V to 5.5V	--	--	50	ns
Data Hold Time	tHD:DAT	VCC = 3V to 5.5V	30	--	--	ns
Data Set-Up Time	tSU:DAT	VCC = 3V to 5.5V	50	--	--	ns

Note 1. Stresses beyond those listed under “Absolute Maximum Ratings” may cause permanent damage to the device. These are stress ratings only, and functional operation of the device at these or any other conditions beyond those indicated in the operational sections of the specifications is not implied. Exposure to absolute maximum rating conditions may affect device reliability.

Note 2. θ_{JA} is measured under natural convection (still air) at $T_A = 25^\circ\text{C}$ with the component mounted on a high effective-thermal-conductivity four-layer test board on a JEDEC 51-7 thermal measurement standard. θ_{JC} is measured at the exposed pad of the package.

Note 3. Devices are ESD sensitive. Handling precautions are recommended.

Note 4. The device is not guaranteed to function outside its operating conditions.

Register Map

Page 1 of Register Table

Address	Length	Register Name	Bit	Bit Name	Default	Type	Description
0x00	1	VENDOR_ID	7:0	VID[7:0]	0xCF	R	A unique 16-bit unsigned integer. Assigned by the USB-IF to the Vendor.
0x01	1		7:0	VID[15:8]	0x29	R	
0x02	1	PRODUCT_ID	7:0	PID[7:0]	0x18	R	A unique 16-bit unsigned integer. Assigned uniquely by the Vendor to identify the TCPC.
0x03	1		7:0	PID[15:8]	0X17	R	
0x04	1	DEVICE_ID	7:0	DID[7:0]	0x14	R	A unique 16-bit unsigned integer. Assigned by the Vendor to identify the version of the TCPC.
0x05	1		7:0	DID[15:8]	0x45	R	
0x06	1	USBTYPEC_REV	7:0	USBTYPEC_REV	0x12	R	Byte 0 of a 16-bit USB Type-C Revision. Revision 1.2
0x07	1		7:0	Reserved	0	R	Reserved
0x08	1	USBPD_REV_VER	7:0	USBPD_VER	0x11	R	Byte 0 of a 16-bit USB PD version. Version 1.1.
0x09	1		7:0	USBPD_REV	0x30	R	Byte 1 of a 16-bit USB PD Revision. Revision 3.0.
0x0A	1	PD_INTERFACE_REV	7:0	PDIF_VER	0x12	R	Byte 0 of a 16-bit PD Interface (TCPC) Version. Version 1.2
0x0B	1		7:0	PDIF_REV	0x10	R	Byte 1 of a 16-bit PD Interface (TCPC) Revision. Revision 1.0

Address	Length	Register Name	Bit	Bit Name	Default	Type	Description
0x10	1	ALERT	7	ALARM_VBUS_VOLTAGE_H	0	RW	0 : Cleared (default) 1 : A high-voltage alarm has occurred
			6	TX_SUCCESS	0	RW	0 : Cleared (default) 1 : Reset or SOP* message transmission successful.
			5	TX_DISCARD	0	RW	0 : Cleared (default) 1 : Reset or SOP* message transmission not sent due to incoming receive message.
			4	TX_FAIL	0	RW	0 : Cleared (default) 1 : SOP* message transmission not successful, no GoodCRC response received on SOP* message transmission.
			3	RX_HARD_RESET	0	RW	0 : Cleared (default) 1 : Received Hard Reset message
			2	RX_SOP_MSG_STATUS	0	RW	0 : Cleared (default) 1 : Receive status register changed
			1	POWER_STATUS	1	RW	0 : Cleared 1 : Port status changed (default)
			0	CC_STATUS	0	RW	0 : Cleared (default) 1 : CC status changed
0x11	1	ALERT	7	VENDOR_DEFINED_ALERT Reserved	0	RW	0 : Cleared (default) 1 : A vendor defined alert has been detected. Defined in the VENDOR_DEFINED registers. Refer to the vendor datasheet for details. This bit can be cleared, regardless of the current status of the alert source.
			6:4	Reserved	000	R	Reserved
			3	VBUS_SINK_DISCNT	0	RW	0 : Cleared (default) 1 : A VBUS Sink Disconnect Threshold crossing has been detected.
			2	RXBUF_OVFLOW	0	RW	0 : TCPC Rx buffer is functioning properly. (default) 1 : TCPC Rx buffer has overflowed.
			1	FAULT	0	RW	0 : No Fault (default) 1 : A Fault has occurred. Read the FAULT_STATUS register.
			0	ALARM_VBUS_VOLTAGE_L	0	RW	0 : Cleared (default) 1 : A low-voltage alarm has occurred

Address	Length	Register Name	Bit	Bit Name	Default	Type	Description
0x12	1	ALERT_MASK	7	M_ALARM_VBUS_VOLTAGE_H	1	RW	0 : Interrupt masked 1 : Interrupt unmasked (default)
			6	M_TX_SUCCESS	1	RW	0 : Interrupt masked 1 : Interrupt unmasked (default)
			5	M_TX_DISCARD	1	RW	0 : Interrupt masked 1 : Interrupt unmasked (default)
			4	M_TX_FAIL	1	RW	0 : Interrupt masked 1 : Interrupt unmasked (default)
			3	M_RX_HARD_RESET	1	RW	0 : Interrupt masked 1 : Interrupt unmasked (default)
			2	M_RX_SOP_MSG_STATUS	1	RW	0 : Interrupt masked 1 : Interrupt unmasked (default)
			1	M_POWER_STATUS	1	RW	0 : Interrupt masked 1 : Interrupt unmasked (default)
			0	M_CC_STATUS	1	RW	0 : Interrupt masked 1 : Interrupt unmasked (default)
0x13	1	ALERT_MASK	7	M_VENDOR_DEFINED_ALERT	0	R	0 : Interrupt masked (default) 1 : Interrupt unmasked
			6:4	Reserved	000	R	Reserved
			3	M_VBUS_SINK_DISCNT	1	R	0 : Interrupt masked 1 : Interrupt unmasked (default)
			2	M_RXBUF_OVERFLOW	1	RW	0 : Interrupt masked 1 : Interrupt unmasked (default)
			1	M_FAULT	1	RW	0 : Interrupt masked 1 : Interrupt unmasked (default)
			0	M_ALARM_VBUS_VOLTAGE_L	1	R	0 : Interrupt masked 1 : Interrupt unmasked (default)

Address	Length	Register Name	Bit	Bit Name	Default	Type	Description
0x14	1	POWER_STATUS_MASK	7	M_DEBUG_ACCESSORY_CONNECT	1	RW	0 : Interrupt masked 1 : Interrupt unmasked (default)
			6	M_TCPC_INITIAL	1	RW	0 : Interrupt masked 1 : Interrupt unmasked (default)
			5	M_SRC_HV	1	RW	0 : Interrupt masked 1 : Interrupt unmasked (default)
			4	M_SRC_VBUS	1	RW	0 : Interrupt masked 1 : Interrupt unmasked (default)
			3	M_VBUS_PRESENT_DETC	1	RW	0 : Interrupt masked 1 : Interrupt unmasked (default)
			2	M_VBUS_PRESENT	1	RW	0 : Interrupt masked 1 : Interrupt unmasked (default)
			1	M_VCONN_PRESENT	1	RW	0 : Interrupt masked 1 : Interrupt unmasked (default)
			0	M_SINK_VBUS	1	RW	0 : Interrupt masked 1 : Interrupt unmasked (default)
0x15	1	FAULT_STATUS_MASK	7	M_ALL_REGISTERS_RESET_TO_DEFAULT	1	RW	0 : Interrupt masked 1 : Interrupt unmasked (default)
			6	M_FORCE_OFF_VBUS	1	RW	0 : Interrupt masked 1 : Interrupt unmasked (default)
			5	M_AUTO_DISC_FAIL	1	RW	0 : Interrupt masked 1 : Interrupt unmasked (default)
			4	M_FORCE_DISC_FAIL	1	RW	0 : Interrupt masked 1 : Interrupt unmasked (default)
			3	M_VBUS_OC	1	RW	0 : Interrupt masked 1 : Interrupt unmasked (default)
			2	M_VBUS_OV	1	RW	0 : Interrupt masked 1 : Interrupt unmasked (default)
			1	M_VCONN_OC	1	RW	0 : Interrupt masked 1 : Interrupt unmasked (default)
			0	M_I2C_ERROR	1	RW	0 : Interrupt masked 1 : Interrupt unmasked (default)

Address	Length	Register Name	Bit	Bit Name	Default	Type	Description
0x18	1	CONFIG_STANDARD_OUTPUT	7	H_IMPEDENCE	0	R	0 : Standard output control (default) 1 : Force all outputs to high impedance May be used to save power in Sleep Controlled by the TCPM.
			6	DBG_ACC_CONNECT	1	RW	0 : Debug Accessory Connected# output is driven low. Debug Accessory connected 1 : Debug Accessory Connected# output is driven high. No Debug Accessory connected. (default) Controlled by either the TCPM or TCPC. The TCPC shall ignore writes to this bit if TCPC_CONTROL.DebugAccessoryControl = 0.
			5	AUDIO_ACC_CONNECT	1	R	Not support.
			4	ACTIVE_CABLE_CONNECT	0	R	Not support.
			3:2	MUX_CTRL	00	R	Not support.
			1	CONNECT_PRESENT	0	R	0 : No Connection (default) 1 : Connection
			0	CONNECT_ORIENTATION	0	RW	0 : Normal (CC1 = A5, CC2 = B5, TX1=A2/A3, RX1=B10/B11) (default) 1 : Flipped (CC2 = A5, CC1 = B5, TX1 = B2/B3, RX1 = A10/A11) Controlled by the TCPM The TCPC shall ignore writes to this bit if TCPC_CONTROL.DebugAccessoryControl = 0.

Address	Length	Register Name	Bit	Bit Name	Default	Type	Description
0x19	1	TCPC_CONTROL	7:6	Reserved	00	R	Reserved
			5	ENABLE_WATCHDOG_TIMER	0	RW	0 : Watchdog Monitoring is disabled. (default) 1 : Watchdog Monitoring is enabled.
			4	DEBUG_ACCESSORY_CONTROL	0	RW	0 : Controlled by TCPC. (default) 1 : Controlled by TCPM. The TCPM writes 1 to this register to take over control of asserting the DebugAccessoryConnected#.
			3:2	I2C_CK_STRETCH	00	R	Not support.
			1	BIST_TEST_MODE	0	RW	0 : Normal Operation. Incoming messages enabled by RECEIVE_DETECT passed to TCPM via Alert. (default) 1 : BIST Test Mode. Incoming messages enabled by RECEIVE_DETECT result in GoodCRC response but may not be passed to the TCPM via Alert. TCPC may temporarily store incoming messages in the Receive Message Buffer, but this may or may not result in a Receive SOP* Message Status or a Rx Buffer Overflow alert.
			0	PLUG_ORIENT	0	RW	0 : When VCONN is enabled, apply it to the CC2 pin. Monitor the CC1 pin for BMC communications if PD messaging is enabled. (default) 1 : When VCONN is enabled, apply it to the CC1 pin. Monitor the CC2 pin for BMC communications if PD messaging is enabled. Required

Address	Length	Register Name	Bit	Bit Name	Default	Type	Description
0x1A	1	ROLE_CONTROL	7	Reserved	0	R	Reserved
			6	DRP	0	RW	0 : No DRP. Bits B3..0 determine Rp/Rd/Ra settings (default) 1 : DRP
			5:4	RP_VALUE	00	RW	00 : Rp default (default) 01 : Rp 1.5A 10 : Rp 3.0A 11 : Reserved
			3:2	CC2	10	RW	00 : Reserved 01 : Rp (Use Rp definition in B5..4) 10 : Rd(default) 11 : Open (Disconnect or don't care) Set to 11b if enabling DRP in B7..6
			1:0	CC1	10	RW	00 : Reserved 01 : Rp (Use Rp definition in B5..4) 10 : Rd (default) 11 : Open (Disconnect or don't care) Set to 11b if enabling DRP in B7..6
0x1B	1	FAULT_CONTROL	7:5	Reserved	000	R	Reserved
			4	DIS_FORCE_OFF_VBUS	0	R	Not support.
			3	DIS_VBUS_DISC_FAULT_TIMER	0	RW	0 : VBUS discharge Fault detection Timer enabled (default) 1 : VBUS discharge Fault detection Timer disabled
			2	DIS_VBUS_OC	0	RW	0 : Internal and External OCP circuit enabled (default) 1 : Internal and External OCP circuit disabled
			1	DIS_VBUS_OV	0	RW	0 : Internal and External OVP circuit enabled (default) 1 : Internal and External OVP circuit disabled
			0	DIS_VCONN_OC	0	RW	0 : Fault detection circuit enabled (default) 1 : Fault detection circuit disabled

Address	Length	Register Name	Bit	Bit Name	Default	Type	Description
0x1C	1	POWER_CONTROL	7	Reserved	0	R	Reserved
			6	VBUS_VOL_MONITOR	1	RW	0 : VBUS_VOLTAGE Monitoring is enabled. 1 : VBUS_VOLTAGE Monitoring is disabled. (default)
			5	DIS_VOL_ALARM	1	RW	0 : Voltage Alarms Power status reporting is enabled. 1 : Voltage Alarms Power status reporting is disabled. (default)
			4	AUTO_DISC_DISCNCT	0	RW	0 : The TCPC shall not automatically discharge VBUS based on VBUS voltage. (default) 1 : The TCPC shall automatically discharge.
			3	EN_BLEED_DISC	0	RW	0 : Disable bleed discharge. (default) 1 : Enable bleed discharge of VBUS
			2	FORCE_DISC	0	RW	0 : Disable force discharge. (default) 1 : Enable force discharge of VBUS.
			1	VCONN_POWER_SPT	0	RW	0 : TCPC delivers at least 1W on VCONN (default) 1 : TCPC delivers at least the power indicated in DEVICE_CAPABILITIES.VCONNPowerSupported
			0	EN_VCONN	0	RW	0 : Disable VCONN Source (default) 1 : Enable VCONN Source to CC Required

Address	Length	Register Name	Bit	Bit Name	Default	Type	Description
0x1D	1	CC_STATUS	7:6	Reserved	00	R	Reserved
			5	LOOKING4 CONNECTION	0	R	0 : TCPC is not actively looking for a connection. A transition from “1” to “0” indicates a potential connection has been found. (default) 1 : TCPC is looking for a connection (toggling as a DRP or looking for a connection as Sink/Source only condition).
			4	Connect_RESULT	0	R	0 : the TCPC is presenting Rp. (default) 1 : the TCPC is presenting Rd.
			3:2	CC2_STATUS	00	R	If (ROLE_CONTROL.CC2 = Rp) or (Connect_Result = 0) 00 : SRC.Open (Open, Rp) (default) 01 : SRC.Ra (below maximum vRa) 10 : SRC.Rd (within the vRd range) 11 : Reserved If (ROLE_CONTROL.CC2 = Rd) or (Connect_Result = 1) 00 : SNK.Open (Below maximum vRa) (default) 01 : SNK.Default (Above minimum vRd-Connect) 10 : SNK.Power1.5 (Above minimum vRd-Connect) Detects Rp 1.5A 11 : SNK.Power3.0 (Above minimum vRd-Connect) Detects Rp 3.0A If ROLE_CONTROL.CC2 = Ra, this field is set to 00b. If ROLE_CONTROL.CC2 = Open, this field is set to 00b. This field always returns 00b if (Looking4Connection = 1) or (POWER_CONTROL.EnableVCONN = 1 and POWER_CONTROL.PlugOrientation = 0). Otherwise, the returned value depends upon ROLE_CONTROL.CC2.

Address	Length	Register Name	Bit	Bit Name	Default	Type	Description
			1:0	CC1_STATUS	00	R	<p>If (ROLE_CONTROL.CC1 = Rp) or (Connect_Result = 0) 00 : SRC.Open (Open, Rp) (default) 01 : SRC.Ra (below maximum vRa) 10 : SRC.Rd (within the vRd range) 11 : Reserved</p> <p>If (ROLE_CONTROL.CC1 = Rd) or Connect_Result = 1) 00 : SNK.Open (Below maximum vRa) (default) 01 : SNK.Default (Above minimum vRd-Connect) 10 : SNK.Power1.5 (Above minimum vRd-Connect) Detects Rp-1.5A 11 : SNK.Power3.0 (Above minimum vRd-Connect) Detects Rp-3.0A</p> <p>If ROLE_CONTROL.CC1 = Ra, this field is set to 00b If ROLE_CONTROL.CC1 = Open, this field is set to 00b</p> <p>This field always returns 00b if (Looking4Connection = 1) or (POWER_CONTROL.EnableVCONN = 1 and POWER_CONTROL.PlugOrientation = 0). Otherwise, the returned value depends upon ROLE_CONTROL.CC1.</p>

Address	Length	Register Name	Bit	Bit Name	Default	Type	Description
0x1E	1	POWER_STATUS	7	DBG_ACC_CONNECT	0	R	0 : No Debug Accessory connected (default) 1 : Debug Accessory connected Reflects the state of the DebugAccessoryConnected# output if supported.
			6	TCPC_INITIAL	0	R	0 : The TCPC has completed initialization and all registers are valid. (default) 1 : The TCPC is still performing internal initialization and the only registers that are guaranteed to return the correct values are 00h..0Fh.
			5	SRC_HV	0	R	0 : vSafe5V (default) 1 : High voltage This does not control the path, just provides a monitor of the status. Assert as long as supplying voltage greater than vSafe5V.
			4	SRC_VBUS	0	R	0 : Sourcing VBUS is disabled. (default) 1 : Sourcing VBUS is enabled. This does not control the path, just provides a monitor of the status.
			3	VBUS_PRESENT_DETC	1	R	0 : VBUS present detection disabled 1 : VBUS present detection enabled (default)
			2	VBUS_PRESENT	0	R	0 : VBUS Disconnected (default) 1 : VBUS Connected
			1	VCONN_PRESENT	0	R	0 : VCONN is not present (default) 1 : This bit is asserted when VCONN present CC1 or CC2. Threshold is fixed at 2.4V
			0	SINK_VBUS	0	R	0 : Sink is Disconnected (default) 1 : TCPC is sinking VBUS to the system load.

Address	Length	Register Name	Bit	Bit Name	Default	Type	Description
0x1F	1	FAULT_STATUS	7	ALL_REGISTERS_RESET_TO_DEFAULT	1	RW	0 : Bit cleared. 1 : When the TCPC resets all registers to their default value. This happens at initial power up or if an unexpected power reset occurs. (default)
			6	FORCE_OFF_VBUS	0	RW	Not support.
			5	AUTO_DISC_FAIL	0	RW	0 : No discharge failure (default) 1 : Discharge commanded by the TCPM failed
			4	FORCE_DISC_FAIL	0	RW	0 : No discharge failure (default) 1 : Discharge commanded by the TCPM failed.
			3	VBUS_OC	0	RW	0 : Not in an over-current protection state (default) 1 : Over-current fault latched
			2	VBUS_OV	0	RW	0 : Not in an over-voltage protection state (default) 1 : Over-voltage fault latched.
			1	VCONN_OC	0	RW	0 : No fault detected (default) 1 : Over-current VCONN fault latched
			0	I2C_ERROR	0	RW	0 : No Error (default) 1 : I ² C error has occurred.

Address	Length	Register Name	Bit	Bit Name	Default	Type	Description
0x23	1	COMMAND	7:0	COMMAND	00000000	W	<p>0000 0000 : No action (default)</p> <p>0001 0001 : Not support</p> <p>0010 0010 : DisableVbusDetect : Disable Vbus present and vSafe0V detection.</p> <p>0011 0011 : EnableVbusDetect : Enable Vbus present and vSafe0V detection.</p> <p>0100 0100 : DisableSinkVbus: Disable sinking power over Vbus. This COMMAND does not disable POWER_STATUS.VBUSPresent detection.</p> <p>0101 0101 : SinkVbus. Enable sinking power over Vbus and enable Vbus present detection. The TCPC shall ignore this command and assert the FAULT_STATUS.I2CInterfaceError if it has sourcing power over Vbus enabled.</p> <p>0110 0110 : DisableSourceVbus. Disable sourcing power over Vbus. The TCPC shall stop reporting FAULT_STATUS. Internal or External OCP or OVP Faults. This COMMAND does not disable POWER_STATUS.VBUSPresent detection.</p> <p>0111 0111 : SourceVbusDefaultVoltage. Enable sourcing vSafe5V over Vbus and enable Vbus present detection. Source shall transition to vSafe5V if at a high voltage. The TCPC shall ignore this command and assert the FAULT_STATUS.I2CInterfaceError if it has sinking power over Vbus enabled.</p> <p>1000 1000 : SourceVbusHighVoltage. Execute sourcing high voltage over Vbus. The TCPC shall ignore this command and assert the FAULT_STATUS.I2CInterfaceError if it is currently sinking voltage from Vbus or does not have ability to source voltages higher than vSafe5V. The TCPC shall ignore this command and assert the FAULT_STATUS.I2CInterfaceError if not already sourcing vSafe5V.</p> <p>1001 1001b : Start DRP Toggling if ROLE_CONTROL.DRP = 1b. If ROLE_CONTROL.CC1/CC2= 01b start with Rp, if ROLE_CONTROL.CC1/CC2 = 10b start with Rd.</p> <p>Other settings : Reserved</p>

Address	Length	Register Name	Bit	Bit Name	Default	Type	Description
0x24	1	DEVICE_CAPABILITYES_1L	7:5	ROLES_SUPPORT	110	R	000 : Type-C Port Manager can configure the Port as Source only or Sink only (not DRP) 001 : Source only 010 : Sink only 011 : Sink with accessory support (optional) 100 : DRP only 101 : Adapter or Cable (Ra) only 110 : Source, Sink, DRP, Adapter/Cable all supported (default) 111 : Not valid
			4	ALL_SOP_SUPPORT	1	R	0 : All SOP* except SOP*_DBG/SOP*_DBG 1 : All SOP* messages are supported (default)
			3	SOURCE_VCONN	1	R	0 : TCPC is not capable of switching VCONN 1 : TCPC is capable of switching VCONN (default)
			2	CPB_SINK_VBUS	1	R	0 : TCPC is not capable controlling the sink path to the system load. 1 : TCPC is capable of controlling the sink path to the system load. (default)
			1	SOURCE_HV_VBUS	1	R	0 : TCPC is not capable of controlling the source high voltage path to VBUS. 1 : TCPC is capable of controlling the source high voltage path to VBUS. (default)
			0	SOURCE_VBUS	1	R	0 : TCPC is not capable of controlling the source path to VBUS. 1 : TCPC is capable of controlling the source path to VBUS. (default)

Address	Length	Register Name	Bit	Bit Name	Default	Type	Description
0x25	1	DEVICE_CAPABILITYES_1H	7	Reserved	0	R	Reserved
			6	CPB_VBUS_OC	1	R	0 : VBUS OCP is not reported by the TCPC 1 : VBUS OCP is reported by the TCPC (default)
			5	CPB_VBUS_OV	1	R	0 : VBUS OVP is not reported by the TCPC 1 : VBUS OVP is reported by the TCPC (default)
			4	CPB_BLEED_DISC	1	R	0 : No Bleed Discharge implemented in TCPC 1 : Bleed Discharge is implemented in the TCPC (default)
			3	CPB_FORCE_DISC	1	R	0b : No Force discharge implemented in TCPC 1b : Force discharge is implemented in the TCPC (default)
			2	VBUS_MEASURE_ALARM	1	R	0 : No VBUS voltage measurement nor VBUS Alarms 1 : VBUS voltage measurement and VBUS Alarms (default)
			1:0	SOURCE_RP_SUPPORT	10	R	00 : Rp default only 01 : Rp 1.5A and default 10 : Rp 3.0A, 1.5A, and default (default) 11 : Reserved Rp values which may be configured by the TCPM via the ROLE_CONTROL register

Address	Length	Register Name	Bit	Bit Name	Default	Type	Description
0x26	1	DEVICE_CAPABILITY_ES_2L	7	SINK_DISCONNECT_DET	1	R	0 : VBUS_SINK_DISCONNECT_THRESHOLD not implemented (default : Use POWER_STATUS.VbusPresent = 0b to indicate a Sink disconnect) 1 : VBUS_SINK_DISCONNECT_THRESHOLD implemented (default)
			6	STOP_DISC_THD	1	R	0 : VBUS_STOP_DISCHARGE_THRESHOLD not implemented 1 : VBUS_STOP_DISCHARGE_THRESHOLD implemented (default)
			5:4	VBUS_VOL_ALARM_LSB	00	R	00 : TCPC has 25mV LSB for its voltage alarm and uses all 10 bits in VBUS_VOLTAGE_ALARM_HI_CFG and VBUS_VOLTAGE_ALARM_LO_CFG. (default) 01 : TCPC has 50mV LSB for its voltage alarm and uses only 9 bits. VBUS_VOLTAGE_ALARM_HI_CFG[0] and VBUS_VOLTAGE_ALARM_LO_CFG[0] are ignored by TCPC. 10 : TCPC has 100mV LSB for its voltage alarm and uses only 8 bits. VBUS_VOLTAGE_ALARM_HI_CFG[1:0] and VBUS_VOLTAGE_ALARM_LO_CFG[1:0] are ignored by TCPC. 11 : Not support this function.
			3:1	VCONN_POWER	000	R	000 : 1.0W (default) 001 : 1.5W 010 : 2.0W 011 : 3W 100 : 4W 101 : 5W 110 : 6W 111 : External
			0	VCONN_OCF	1	R	0 : TCPC is not capable of detecting a VCONN fault 1 : TCPC is capable of detecting a VCONN fault (default)
			7:1	Reserved	0000000	R	Reserved
0x27	1	DEVICE_CAPABILITY_ES_2H	0	CPB_WATCHDOG	1	R	0 : TCPC_CONTROL.Enable Watchdog Timer not implemented 1 : TCPC_CONTROL.Enable Watchdog Timer implemented (default)
			7:1	Reserved	0000000	R	Reserved

Address	Length	Register Name	Bit	Bit Name	Default	Type	Description
0x28	1	STANDARD_INPUT_CAPABILITIES	7:3	Reserved	00000	R	Reserved
			2	VBUS_EXT_OVF	0	R	0 : Not present in TCPC (default) 1 : Present in TCPC
			1	VBUS_EXT_OCF	0	R	0 : Not present in TCPC (default) 1 : Present in TCPC
			0	FORCE_OFF_VBUS_IN	0	R	0 : Not present in TCPC (default) 1 : Present in TCPC
0x29	1	STANDARD_OUTPUT_CAPABILITIES	7	Reserved	0	R	Reserved
			6	CPB_DBG_ACC_IND	0	R	0 : Not present in TCPC (default) 1 : Present in TCPC
			5	CPB_VBUS_PRESENT_MNT	0	R	0 : Not present in TCPC (default) 1 : Present in TCPC
			4	CPB_AUDIO_ADT_ACC_IND	0	R	0 : Not present in TCPC (default) 1 : Present in TCPC
			3	CPB_ACTIVE_CABLE_IND	0	R	0 : Not present in TCPC (default) 1 : Present in TCPC
			2	CPB_MUX_CFG_CTRL	0	R	0 : Not present in TCPC (default) 1 : Present in TCPC
			1	CPB_CONNECT_PRESENT	0	R	0 : Not present in TCPC (default) 1 : Present in TCPC
			0	CPB_CONNECT_ORIENT	0	R	0 : Not present in TCPC (default) 1 : Present in TCPC
0x2E	1	MESSAGE_HEADER_INFO	7:5	Reserved	000	R	Reserved
			4	CABLE_PLUG	0	RW	0 : Message originated from Source, Sink, or DRP (default) 1 : Message originated from a Cable Plug
			3	DATA_ROLE	0	RW	0 : Sink (default) 1 : Source
			2:1	USBDPD_SPECREV	01	RW	00 : Revision 1.0 01 : Revision 2.0 (default) 10 : Revision 3.0 11 : Reserved
			0	POWER_ROLE	0	RW	0 : Sink (default) 1 : Source

Address	Length	Register Name	Bit	Bit Name	Default	Type	Description
0x2F	1	RECEIVE_DETECT	7	Reserved	0	R	Reserved
			6	EN_CABLE_RST	0	RW	0 : TCPC does not detect Cable Reset signaling (default) 1 : TCPC detects Cable Reset signaling
			5	EN_HARD_RST	0	RW	0 : TCPC does not detect Hard Reset signaling (default) 1 : TCPC detects Hard Reset signaling
			4	EN_SOP2DB	0	RW	0 : TCPC does not detect SOP_DBG' message (default) 1 : TCPC detects SOP_DBG'' message
			3	EN_SOP1DB	0	RW	0 : TCPC does not detect SOP_DBG' message (default) 1 : TCPC detects SOP_DBG' message
			2	EN_SOP2	0	RW	0 : TCPC does not detect SOP'' message (default) 1 : TCPC detects SOP'' message
			1	EN_SOP1	0	RW	0b : TCPC does not detect SOP' message (default) 1b : TCPC detects SOP' message
			0	EN_SOP	0	RW	0 : TCPC does not detect SOP message (default) 1 : TCPC detects SOP message
0x30	1	RX_BYTE_COUNT	7:0	RX_BYTE_COUNT	0x00	RW	Indicates number of bytes in this register that are not stale. The TCPM should read the first RECEIVE_BYTE_COUNT bytes in this register.
0x31	1	RX_BUF_FRAME_TYPE	7:3	Reserved	00000	R	Reserved
			2:0	RX_FRAME_TYPE	000	R	Type of received frame 000 : Received SOP (default) 001 : Received SOP' 010 : Received SOP'' 011 : Received SOP_DBG' 100 : Received SOP_DBG'' 110 : Received Cable Reset All others are reserved.
0x32	1	RX_BUF_HEADER_BYTE_0	7:0	RX_HEAD_0	0x00	R	Byte 0 (bits 7..0) of message header
0x33	1	RX_BUF_HEADER_BYTE_1	7:0	RX_HEAD_1	0x00	R	Byte 1 (bits 15..8) of message header
0x34	1	RX_BUF_OBJ1_BYTE_0	7:0	RX_OBJ1_0	0x00	R	Byte 0 (bits 7..0) of 1st data object
0x35	1	RX_BUF_OBJ1_BYTE_1	7:0	RX_OBJ1_1	0x00	R	Byte 1 (bits 15..8) of 1st data object

Address	Length	Register Name	Bit	Bit Name	Default	Type	Description
0x36	1	RX_BUF_OBJ1_BYTE_2	7:0	RX_OBJ1_2	0x00	R	Byte 2 (bits 23..16) of 1st data object
0x37	1	RX_BUF_OBJ1_BYTE_3	7:0	RX_OBJ1_3	0x00	R	Byte 3 (bits 31..24) of 1st data object
0x38	1	RX_BUF_OBJ2_BYTE_0	7:0	RX_OBJ2_0	0x00	R	Byte 0 (bits 7..0) of 2st data object
0x39	1	RX_BUF_OBJ2_BYTE_1	7:0	RX_OBJ2_1	0x00	R	Byte 1 (bits 15..8) of 2st data object
0x3A	1	RX_BUF_OBJ2_BYTE_2	7:0	RX_OBJ2_2	0x00	R	Byte 2 (bits 23..16) of 2st data object
0x3B	1	RX_BUF_OBJ2_BYTE_3	7:0	RX_OBJ2_3	0x00	R	Byte 3 (bits 31..24) of 2st data object
0x3C	1	RX_BUF_OBJ3_BYTE_0	7:0	RX_OBJ3_0	0x00	R	Byte 0 (bits 7..0) of 3st data object
0x3D	1	RX_BUF_OBJ3_BYTE_1	7:0	RX_OBJ3_1	0x00	R	Byte 1 (bits 15..8) of 3st data object
0x3E	1	RX_BUF_OBJ3_BYTE_2	7:0	RX_OBJ3_2	0x00	R	Byte 2 (bits 23..16) of 3st data object
0x3F	1	RX_BUF_OBJ3_BYTE_3	7:0	RX_OBJ3_3	0x00	R	Byte 3 (bits 31..24) of 3st data object
0x40	1	RX_BUF_OBJ4_BYTE_0	7:0	RX_OBJ4_0	0x00	R	Byte 0 (bits 7..0) of 4st data object
0x41	1	RX_BUF_OBJ4_BYTE_1	7:0	RX_OBJ4_1	0x00	R	Byte 1 (bits 15..8) of 4st data object
0x42	1	RX_BUF_OBJ4_BYTE_2	7:0	RX_OBJ4_2	0x00	R	Byte 2 (bits 23..16) of 4st data object
0x43	1	RX_BUF_OBJ4_BYTE_3	7:0	RX_OBJ4_3	0x00	R	Byte 3 (bits 31..24) of 4st data object
0x44	1	RX_BUF_OBJ5_BYTE_0	7:0	RX_OBJ5_0	0x00	R	Byte 0 (bits 7..0) of 5st data object
0x45	1	RX_BUF_OBJ5_BYTE_1	7:0	RX_OBJ5_1	0x00	R	Byte 1 (bits 15..8) of 5st data object

Address	Length	Register Name	Bit	Bit Name	Default	Type	Description
0x46	1	RX_BUF_OBJ5_BYTE_2	7:0	RX_OBJ5_2	0x00	R	Byte 2 (bits 23..16) of 5st data object
0x47	1	RX_BUF_OBJ5_BYTE_3	7:0	RX_OBJ5_3	0x00	R	Byte 3 (bits 31..24) of 5st data object
0x48	1	RX_BUF_OBJ6_BYTE_0	7:0	RX_OBJ6_0	0x00	R	Byte 0 (bits 7..0) of 6st data object
0x49	1	RX_BUF_OBJ6_BYTE_1	7:0	RX_OBJ6_1	0x00	R	Byte 1 (bits 15..8) of 6st data object
0x4A	1	RX_BUF_OBJ6_BYTE_2	7:0	RX_OBJ6_2	0x00	R	Byte 2 (bits 23..16) of 6st data object
0x4B	1	RX_BUF_OBJ6_BYTE_3	7:0	RX_OBJ6_3	0x00	R	Byte 3 (bits 31..24) of 6st data object
0x4C	1	RX_BUF_OBJ7_BYTE_0	7:0	RX_OBJ7_0	0x00	R	Byte 0 (bits 7..0) of 7st data object
0x4D	1	RX_BUF_OBJ7_BYTE_1	7:0	RX_OBJ7_1	0x00	R	Byte 1 (bits 15..8) of 7st data object
0x4E	1	RX_BUF_OBJ7_BYTE_2	7:0	RX_OBJ7_2	0x00	R	Byte 2 (bits 23..16) of 7st data object
0x4F	1	RX_BUF_OBJ7_BYTE_3	7:0	RX_OBJ7_3	0x00	R	Byte 3 (bits 31..24) of 7st data object
0x50	1	X_BUF_FRAME_TYPE	7:6	Reserved	00	R	Reserved
			5:4	TX_RETRY_CNT	00	RW	00 : No message retry is required (default) 01 : Automatically retry message transmission once 10 : Automatically retry message transmission twice 11 : Automatically retry message transmission three times
			3	Reserved	0	R	Reserved
			2:0	TX_FRAME_TYPE	000	RW	000 : Transmit SOP (default) 001 : Transmit SOP' 010 : Transmit SOP'' 011 : Transmit SOP_DBG' 100 : Transmit SOP_DBG'' 101 : Transmit Hard Reset 110 : Transmit Cable Reset 111 : Transmit BIST Carrier Mode 2 (TCPC shall exit the BIST mode no later than tBISTContMode max)

Address	Length	Register Name	Bit	Bit Name	Default	Type	Description
0x51	1	TX_BYTE_COUNT	7:0	TX_BYTE_COUNT	0x00	RW	The number of bytes the TCPM will write
0x52	1	TX_BUF_HEADER_BYTE_0	7:0	TX_HEAD_0	0x00	RW	Byte 0 (bits 7..0) of message header
0x53	1	TX_BUF_HEADER_BYTE_1	7:0	TX_HEAD_1	0x00	RW	Byte 1 (bits 15..8) of message header
0x54	1	TX_BUF_OBJ1_BYTE_0	7:0	TX_OBJ1_0	0x00	RW	Byte 0 (bits 7..0) of 1st data object
0x55	1	TX_BUF_OBJ1_BYTE_1	7:0	TX_OBJ1_1	0x00	RW	Byte 1 (bits 15..8) of 1st data object
0x56	1	TX_BUF_OBJ1_BYTE_2	7:0	TX_OBJ1_2	0x00	RW	Byte 2 (bits 23..16) of 1st data object
0x57	1	TX_BUF_OBJ1_BYTE_3	7:0	TX_OBJ1_3	0x00	RW	Byte 3 (bits 31..24) of 1st data object
0x58	1	TX_BUF_OBJ2_BYTE_0	7:0	TX_OBJ2_0	0x00	RW	Byte 0 (bits 7..0) of 2st data object
0x59	1	TX_BUF_OBJ2_BYTE_1	7:0	TX_OBJ2_1	0x00	RW	Byte 1 (bits 15..8) of 2st data object
0x5A	1	TX_BUF_OBJ2_BYTE_2	7:0	TX_OBJ2_2	0x00	RW	Byte 2 (bits 23..16) of 2st data object
0x5B	1	TX_BUF_OBJ2_BYTE_3	7:0	TX_OBJ2_3	0x00	RW	Byte 3 (bits 31..24) of 2st data object
0x5C	1	TX_BUF_OBJ3_BYTE_0	7:0	TX_OBJ3_0	0x00	RW	Byte 0 (bits 7..0) of 3st data object
0x5D	1	TX_BUF_OBJ3_BYTE_1	7:0	TX_OBJ3_1	0x00	RW	Byte 1 (bits 15..8) of 3st data object
0x5E	1	TX_BUF_OBJ3_BYTE_2	7:0	TX_OBJ3_2	0x00	RW	Byte 2 (bits 23..16) of 3st data object
0x5F	1	TX_BUF_OBJ3_BYTE_3	7:0	TX_OBJ3_3	0x00	RW	Byte 3 (bits 31..24) of 3st data object
0x60	1	TX_BUF_OBJ4_BYTE_0	7:0	TX_OBJ4_0	0x00	RW	Byte 0 (bits 7..0) of 4st data object

Address	Length	Register Name	Bit	Bit Name	Default	Type	Description
0x61	1	TX_BUF_OBJ4_BYTE_1	7:0	TX_OBJ4_1	0x00	RW	Byte 1 (bits 15..8) of 4st data object
0x62	1	TX_BUF_OBJ4_BYTE_2	7:0	TX_OBJ4_2	0x00	RW	Byte 2 (bits 23..16) of 4st data object
0x63	1	TX_BUF_OBJ4_BYTE_3	7:0	TX_OBJ4_3	0x00	RW	Byte 3 (bits 31..24) of 4st data object
0x64	1	TX_BUF_OBJ5_BYTE_0	7:0	TX_OBJ5_0	0x00	RW	Byte 0 (bits 7..0) of 5st data object
0x65	1	TX_BUF_OBJ5_BYTE_1	7:0	TX_OBJ5_1	0x00	RW	Byte 1 (bits 15..8) of 5st data object
0x66	1	TX_BUF_OBJ5_BYTE_2	7:0	TX_OBJ5_2	0x00	RW	Byte 2 (bits 23..16) of 5st data object
0x67	1	TX_BUF_OBJ5_BYTE_3	7:0	TX_OBJ5_3	0x00	RW	Byte 3 (bits 31..24) of 5st data object
0x68	1	TX_BUF_OBJ6_BYTE_0	7:0	TX_OBJ6_0	0x00	RW	Byte 0 (bits 7..0) of 6st data object
0x69	1	TX_BUF_OBJ6_BYTE_1	7:0	TX_OBJ6_1	0x00	RW	Byte 1 (bits 15..8) of 6st data object
0x6A	1	TX_BUF_OBJ6_BYTE_2	7:0	TX_OBJ6_2	0x00	RW	Byte 2 (bits 23..16) of 6st data object
0x6B	1	TX_BUF_OBJ6_BYTE_3	7:0	TX_OBJ6_3	0x00	RW	Byte 3 (bits 31..24) of 6st data object
0x6C	1	TX_BUF_OBJ7_BYTE_0	7:0	TX_OBJ7_0	0x00	RW	Byte 0 (bits 7..0) of 7st data object
0x6D	1	TX_BUF_OBJ7_BYTE_1	7:0	TX_OBJ7_1	0x00	RW	Byte 1 (bits 15..8) of 7st data object
0x6E	1	TX_BUF_OBJ7_BYTE_2	7:0	TX_OBJ7_2	0x00	RW	Byte 2 (bits 23..16) of 7st data object
0x6F	1	TX_BUF_OBJ7_BYTE_3	7:0	TX_OBJ7_3	0x00	RW	Byte 3 (bits 31..24) of 7st data object
0x70	1	VBUS_VOLTAGE_L	7:0	VBUS_VOLTAGE [7:0]	0x00	R	VBUS voltage [7:0] The LSB is 25mV.

Address	Length	Register Name	Bit	Bit Name	Default	Type	Description
0x71	1	VBUS_VOLTAGE_H	7:4	Reserved	0000	R	Reserved
			3:2	Scale_Factor	00	RW	00 : VBUS measurement not scaled. (default) 01 : VBUS measurement divided by 2 10 : VBUS measurement divided by 4 11 : Reserved
			1:0	VBUS_VOLTAGE[9:8]	00	R	VBUS voltage [9:8]
0x72	1	VBUS_SINK_DISCONNECT_THRESHOLD_L	7:0	VBUS_SINK_DISCNT_THD[7:0]	0x8C	RW	VBUS_SINK_DISCNT_THD[7:0] The LSB is 25mV.
0x73	1	VBUS_SINK_DISCONNECT_THRESHOLD_H	7:2	Reserved	000000	R	Reserved
			1:0	VBUS_SINK_DISCNT_THD[9:8]	00	RW	VBUS_SINK_DISCNT_THD[9:8]
0x74	1	VBUS_STOP_DISCHARGE_THRESHOLD_L	7:0	VBUS_STOP_DISCHARGE_THRESHOLD[7:0]	0x20	RW	VBUS_STOP_DISCHARGE_THRESHOLD[7:0] The LSB is 25mV.
0x75	1	VBUS_STOP_DISCHARGE_THRESHOLD_H	7:2	Reserved	000000	R	Reserved
			1:0	VBUS_STOP_DISCHARGE_THRESHOLD[9:8]	00	RW	VBUS_STOP_DISCHARGE_THRESHOLD[9:8]
0x76	1	VBUS_VOLTAGE_ALARM_HI_L	7:0	VBUS_VOLTAGE_ALARM_HI[7:0]	0x00	RW	VBUS_VOLTAGE_ALARM_HI[7:0] The LSB is 25mV.
0x77	1	VBUS_VOLTAGE_ALARM_HI_H	7:2	Reserved	000000	R	Reserved
			1:0	VBUS_VOLTAGE_ALARM_HI[9:8]	00	RW	VBUS_VOLTAGE_ALARM_HI[9:8]
0x78	1	VBUS_VOLTAGE_ALARM_LO_L	7:0	VBUS_VOLTAGE_ALARM_LO[7:0]	0x00	RW	VBUS_VOLTAGE_ALARM_LO[7:0] The LSB is 25mV.
0x79	1	VBUS_VOLTAGE_ALARM_LO_H	7:2	Reserved	000000	R	Reserved
			1:0	VBUS_VOLTAGE_ALARM_LO[9:8]	00	RW	VBUS_VOLTAGE_ALARM_LO[9:8]

Address	Length	Register Name	Bit	Bit Name	Default	Type	Description
0x8A	1	VCONN_CONTROL_1	7	VCONN_DETECT_EN	0	RW	CC pin (Vconn) detection enable for Vconn_Present, Vconn_safe0V, and Vconn_Invalid. 0 : Disable (default) 1 : Enable
			6	VCONN_SWOFF	0	RW	PD_RP switch control when Vconn enabled 0 : PD_RP switch on when Vconn enabled (default) 1 : PD_RP switch off when Vconn enabled
			5	VCONN_UVP_SEL	0	RW	VCONN UVP level selection 0 : 2.7V (default) 1 : 2.4V
			4:0	Reserved	00000	RW	Reserved
0x8B	1	VCONN_CONTROL_2	7	VCONN_OVP_EN_CC1	0	RW	Enable CC1 OVP. The OVP threshold is 5.75V at CC1. 0 : Disable (default) 1 : Enable
			6	VCONN_OVP_EN_CC2	0	RW	Enable CC2 OVP. The OVP threshold is 5.75V at CC2. 0 : Disable (default) 1 : Enable
			5:4	VCONN_SHT_GND_TIMER	10	RW	When VCONN_EN = 1 (0x1E[0] = 1b), VCONN_SHT_GND will be 1 (0xA0[5] = 1b) if VCONN_PRESENT is always 0 and lasts for VCONN_SHT_GND_TIMER. 00 : 0.5ms 01 : 0.75ms 10 : 1ms (default) 11 : 3ms
			3	VCONN_RVP_EN	0	RW	VCONN RVP Enable. VCONN switch will be off if the voltage at CC (selected for VCONN) is higher than VCONN by VCONN_RVP_SEL (0x8B[2]). 0 : Disable (default) 1 : Enable
			2	VCONN_RVP_SEL	0	RW	VCONN RVP threshold selection 0 : 0.3V (default) 1 : 0.5V
			1	VCONN_RVP_CP_EN	1	RW	VCONN RVP de-bounce time 0 : de-bounce 3.125μs (typical) 1 : No de-bounce (default)
			0	VCONN_SOFTEND_TIMER	0	RW	The time for which VCONN current limit is enabled after VCONN EN (0x1C[0] = 1b). 0 : 3ms (default) 1 : 5ms

Address	Length	Register Name	Bit	Bit Name	Default	Type	Description
0x8C	1	VCONN_CONTROL_3	7:5	VCONN_OCP_SEL	010	RW	PD_VCONN OCP level selection 000 : 100mA 001 : 200mA 010 : 300mA (default) 011 : 400mA 100 : 500mA 101 : 600mA 110 : 700mA 111 : 800mA
			4	Reserved	0	R	Reserved
			3:2	Reserved	00	RW	Reserved
			1	VCONN_OVP_DEG	0	RW	VCONN OVP de-bounce time 0 : No de-bounce (default) 1 : De-bounce 3.125μs (typical)
			0	Reserved	0	RW	Reserved
0x8F	1	SYS_CTRL_1	7	IRQB_SELECT	0	RW	Select IRQB from synchronous to 3M path or original path. 0 : Original asynchronous path. (default) 1 : Synchronous to 3M path.
			6	TCPC_CONN_INVALID	1	RW	Enable TCPC connect invalid state machine to trigger I ² C interface error interrupt. 0 : Disable 1 : Enable (default)
			5	SHIPPING_OFF	0	RW	Only I ² C function works in shipping mode. 0 : Shipping mode (default) 1 : Non shipping mode
			4	Reserved	1	R	Reserved
			3	AUTOIDLE_EN	0	RW	Auto entering idle mode 0 : No entering idle mode (default) 1 : Auto entering idle mode
			2:0	AUTOIDLE_TIMEOUT	010	RW	Auto idle mode timer 000 : 6.4ms 001 : 19.2ms 010 : 32ms (default) 011 : 44.8ms 100 : 57.6ms 101 : 70.4ms 110 : 83.2ms 111 : 96ms

Address	Length	Register Name	Bit	Bit Name	Default	Type	Description
0x90	1	SYS_CTRL_2	7	VBUS_SAFE0V_DET_EN	1	RW	VBUS Safe0V detection 0 : Disable detection 1 : Enable detection (default)
			6	Reserved	0	RW	Reserved
			5	VCONN_DISCHARGE_EN	0	RW	Discharge at VCONN pin (pin 6) when there is VCONN fault. 0 : No discharge (default) 1 : Discharge when there is VCONN fault
			4:3	Reserved	00	RW	Reserved
			2	VBUS_VALID_DET_EN	1	RW	VBUS valid detection 0 : Disable detection 1 : Enable detection (default)
			1	VBUS_PRESENT_DET_EN	1	RW	VBUS present detection 0 : Disable detection 1 : Enable detection (default)
			0	Reserved	1	RW	Reserved
0x91	1	RT_MASK_1	7	M_VBUS_FRS_LOW	0	RW	0 : Interrupt masked (default) 1 : Interrupt unmasked
			6	M_RX_FRS	0	RW	0 : Interrupt masked (default) 1 : Interrupt unmasked
			5	M_VBUS_VALID	0	RW	0 : Interrupt masked (default) 1 : Interrupt unmasked
			4	M_LEGACY_CABLE_CC2	0	RW	0 : Interrupt masked (default) 1 : Interrupt unmasked
			3	M_LEGACY_CABLE_CC1	0	RW	0 : Interrupt masked (default) 1 : Interrupt unmasked
			2	Reserved	0	RW	Reserved
			1	M_VBUS_SAFE0V	0	RW	0 : Interrupt masked (default) 1 : Interrupt unmasked
			0	M_WAKEUP	0	RW	0 : Interrupt masked (default) 1 : Interrupt unmasked

Address	Length	Register Name	Bit	Bit Name	Default	Type	Description
0x92	1	RT_MASK2	7	Reserved	0	RW	Reserved
			6	M_VCONN_SAFE0V	0	RW	0 : Interrupt masked (default) 1 : Interrupt unmasked
			5	M_VCONN_SHT_GND	0	RW	0 : Interrupt masked (default) 1 : Interrupt unmasked
			4	M_VCONN_UVP	0	RW	0 : Interrupt masked (default) 1 : Interrupt unmasked
			3	Reserved	0	RW	Reserved
			2	M_VCONN_RVP	0	RW	0 : Interrupt masked (default) 1 : Interrupt unmasked
			1	M_VCONN_OV_CC2	0	RW	0 : Interrupt masked (default) 1 : Interrupt unmasked
			0	M_VCONN_OV_CC1	0	RW	0 : Interrupt masked (default) 1 : Interrupt unmasked
0x93	1	RT_MASK3	7	M_CMP_VBUS_TO_CC2	0	RW	0 : Interrupt masked (default) 1 : Interrupt unmasked
			6	M_CMP_VBUS_TO_CC1	0	RW	0 : Interrupt masked (default) 1 : Interrupt unmasked
			5	M_TX_DISCARD_TIMEOUT	0	RW	0 : Interrupt masked (default) 1 : Interrupt unmasked
			4	M_CABLE_TYPE	0	RW	0 : Interrupt masked (default) 1 : Interrupt unmasked
			3:0	Reserved	0000	RW	Reserved
0x96	1	RT_MASK6	7	M_BC12_SNK_DONE	0	RW	0 : Interrupt masked (default) 1 : Interrupt unmasked
			6	M_HVDCP_CHK_DONE	0	RW	0 : Interrupt masked (default) 1 : Interrupt unmasked
			5	M_BC12_TA_CHG	0	RW	0 : Interrupt masked (default) 1 : Interrupt unmasked
			4:3	Reserved	00	RW	Reserved
			2	M_SBUDPDM_SW	0	RW	0 : Interrupt masked (default) 1 : Interrupt unmasked
			1	Reserved	0	RW	Reserved
			0	M_ADC_DONE	0	RW	0 : Interrupt masked (default) 1 : Interrupt unmasked
0x97	1	RT_MASK7	7	M_VDC_UVP	0	RW	0 : Interrupt masked (default) 1 : Interrupt unmasked
			6	M_TIMER_TIMEOUT	0	RW	0 : Interrupt masked (default) 1 : Interrupt unmasked
			5:0	Reserved	000000	RW	Reserved

Address	Length	Register Name	Bit	Bit Name	Default	Type	Description
0x98	1	RT_INT1	7	INT_VBUS_FRS_LOW	0	RW	0 : Cleared (default) 1 : Fast role swap Vbus valid falling (< 4.75V)
			6	INT_RX_FRS	0	RW	0 : Cleared (default) 1 : Fast-role swap rx detection alert.
			5	INT_VBUS_VALID	0	RW	0 : Cleared (default) 1 : VBUS VALID Rising or Falling
			4	INT_LEGACY_CABLE_CC2	0	RW	0 : Cleared (default) 1 : Legacy Cable status change
			3	INT_LEGACY_CABLE_CC1	0	RW	0 : Cleared (default) 1 : Legacy cable status change
			2	Reserved	0	RW	Reserved
			1	INT_VBUS_SAFE0V	0	RW	0 : Cleared (default) 1 : VBUS under 0.8V
			0	INT_WAKEUP	0	RW	0 : Cleared (default) 1 : Exit low-power mode
0x99	1	RT_INT2	7	Reserved	0	RW	Reserved
			6	INT_VCONN_SAFE0V	0	RW	0 : Cleared or No VCONN_SAFE0V flag rising (default) 1 : VCONN Voltage drop from greater than 0.8V to lower than 0.8V.
			5	INT_VCONN_SHT_GND	0	RW	0 : Cleared (default) 1 : VCONN Pre short to ground
			4	INT_VCONN_UVP	0	RW	0 : Cleared (default) 1 : VCONN voltage less than VCONN_INVALID (2.7V) when VCONN_UVP_SEL = 0 (0x8A[5]), or VCONN voltage less than VCONN_PRESENT (2.4V) when VCONN_UVP_SEL = 1 (0x8A[5])
			3	Reserved	0	RW	Reserved
			2	INT_VCONN_RVP	0	RW	0 : Cleared (default) 1 : VCONN RVP event is detected.
			1	INT_VCONN_OV_CC2	0	RW	0 : Cleared (default) 1 : CC2 OVP event is detected.
			0	INT_VCONN_OV_CC1	0	RW	0 : Cleared (default) 1 : CC1 OVP event is detected.

Address	Length	Register Name	Bit	Bit Name	Default	Type	Description
0x9A	1	RT_INT3	7	INT_CMP_VBUS_TO_CC2	0	RW	0 : Cleared (default) 1 : VBUS to CC voltage detection (> 3.45V)
			6	INT_CMP_VBUS_TO_CC1	0	RW	0 : Cleared (default) 1 : VBUS to CC voltage detection (> 3.45V)
			5	INT_TX_DISCARD_TIMEOUT	0	RW	Indicate TX_DISCARD interrupt is caused by TXINT_TIMER timeout. 0 : Cleared (default) 1 : TX DISCARD TIMEOUT
			4	INT_CTD	0	RW	0 : Cleared (default) 1 : Cable type detect done indication.
			3:0	Reserved	0000	RW	Reserved
0x9D	1	RT_INT6	7	INT_BC12_SNK_DONE	0	RW	0 : Cleared (default) 1 : BC12 sink flow done
			6	INT_HVDCP_CHK_DONE	0	RW	0 : Cleared (default) 1 : HVDCP flow check done (sink side)
			5	INT_BC12_TA_CHG	0	RW	0 : Cleared (default) 1 : BC12 source flow status change (CDP)
			4:3	Reserved	00	RW	Reserved
			2	INT_SBUDPDM_SW	0	RW	0 : Cleared (default) 1 : SBU/DPDM switch status change
			1	Reserved	0	RW	Reserved
			0	INT_ADC_DONE	0	RW	0 : Cleared (default) 1 : ADC done
0x9E	1	RT_INT7	7	INT_VDC_UVP	0	RW	0 : Cleared (default) 1 : VDC UVP flag rising/falling interrupt
			6	INT_TIMER_TIMEOUT	0	RW	0 : Cleared (default) 1 : Timer count reach
			5:0	Reserved	000000	RW	Reserved

Address	Length	Register Name	Bit	Bit Name	Default	Type	Description
0x9F	1	RT_ST1	7	VBUS_FRS_LOW	0	R	VBUS FRS voltage detection 0 : VBUS < VREF_VBUS_FRS (default) 1 : VBUS > VREF_VBUS_FRS
			6	RX_FRS	0	R	Fast-role swap rx detection alert. 0 : CC > VREF_RX_FR (default) 1 : CC < VREF_RX_FR
			5	VBUS_VALID	0	R	0 : When VBUS voltage is lower than VREF_VBUS_VALID (default) 1 : When VBUS voltage is higher than VREF_VBUS_VALID
			4	LEGACY_CABLE_CC2	0	R	Legacy Cable Detection 0 : No Legacy Cable on CC2 (default) 1 : Legacy Cable on CC2
			3	LEGACY_CABLE_CC1	0	R	Legacy Cable Detection 0 : No Legacy Cable on CC1 (default) 1 : Legacy Cable on CC1
			2	Reserved	0	R	Reserved
			1	VBUS_SAFE0V	0	R	0 : When VBUS voltage is higher than 0.8V. (default) 1 : When VBUS voltage is lower than 0.8V.
			0	Reserved	0	R	Reserved

Address	Length	Register Name	Bit	Bit Name	Default	Type	Description
0xA0	1	RT_ST2	7	Reserved	0	R	Reserved
			6	VCONN_SAFE0V	0	R	VCONN compare to 0.8V result 0 : indicate VCONN Voltage at CC is higher than 0.8V (default) 1 : indicate VCONN Voltage at CC is less than 0.8V
			5	VCONN_SHT_GND	0	R	VCONN-short-to-GND means VCONN at CC is not higher than 2.4V after VCONN_SHT_GND_TIMER when VCONN_EN is enabled. 0 : No VCONN short to GND (default) 1 : VCONN short to GND
			4	VCONN_UVP	0	R	VCONN under-voltage protect 0 : VCONN voltage at CC is higher than VCONN_INVALID (2.7V) when VCONN_UVP_SEL = 0 (0x8A[5]), or VCONN voltage higher than VCONN_PRESENT (2.4V) when VCONN_UVP_SEL = 1 (0x8A[5]) (default) 1 : VCONN voltage at CC is less than VCONN_INVALID (2.7V) when VCONN_UVP_SEL = 0 (0x8A[5]), or VCONN voltage less than VCONN_PRESENT (2.4V) when VCONN_UVP_SEL = 1 (0x8A[5])
			3	VCONN_OCP_FLAG	0	R	0 : VCONN current is lower than VCONN_OCP_SEL setting. (default) 1 : VCONN current is higher than VCONN_OCP_SEL setting.
			2	VCONN_RVP	0	R	When CC (selected for VCONN) voltage is higher than VCONN, VCONN RV event will occur. 0 : No VCONN RV occur (default) 1 : VCONN RV occurs.
			1	VCONN_OV_CC2	0	R	0 : CC2 voltage is lower than 5.7V. (default) 1 : CC2 voltage is higher than 5.75V. Note : This bit works when VCONN_OVP_EN_CC2 is enabled.
			0	VCONN_OV_CC1	0	R	0 : CC1 voltage is lower than 5.7V. (default) 1 : CC1 voltage is higher than 5.75V. Note : This bit works when VCONN_OVP_EN_CC1 is enabled.

Address	Length	Register Name	Bit	Bit Name	Default	Type	Description
0xA1	1	RT_ST3	7	CMP_VBUS_TO_CC2	0	R	Result of VBUS short to CC2 detection. 0 : CC2 voltage is less than 3.45V. (default) 1 : CC2 voltage is higher than 3.45V. Note : This bit works when CMPEN_VBUS_TO_CC2 is set to 1.
			6	CMP_VBUS_TO_CC1	0	R	Result of VBUS short to CC1 detection. 0 : CC1 voltage is less than 3.45V. (default) 1 : CC1 voltage is higher than 3.45V. Note : This bit works when CMPEN_VBUS_TO_CC1 is set to 1.
			5	CABLE_TYPEA	0	R	Cable Type-A detect result. 0 : Not Type-A indication or Cable type detection not done yet (default) 1 : Type-A indication
			4	CABLE_TYPEC	0	R	Cable Type C detect result. 0 : Not Type-C indication or Cable Type Detection not done yet (default) 1 : Type-C
			3:0	Reserved	0000	R	Reserved
0xA4	1	RT_ST6	7	BC12_SNK_DONE	0	R	0 : Cleared (default) 1 : BC12 sink flow done
			6	HVDCP_CHK_DONE	0	R	0 : Cleared (default) 1 : HVDCP flow check done (sink side)
			5	BC12_TA_CHG	0	R	0 : Cleared (default) 1 : BC12 source flow status change (CDP/ private protocol) Note : This flag only keeps 0.33μs.
			4:3	Reserved	00	R	Reserved
			2	SBUDPDM_SW	0	R	0 : Cleared (default) 1 : SBU/DPDM switch status change Note : This flag only keeps 0.33us
			1:0	Reserved	00	R	Reserved
0xA5	1	RT_ST7	7	VDC_UVP	0	R	0 : No action or not done yet (default) 1 : VDC UVP flag
			6:0	Reserved	0000000	R	Reserved

Address	Length	Register Name	Bit	Bit Name	Default	Type	Description
0xA6	1	RT_MASK8	7	MASK_BGOK_CHG	0	RW	0 : Interrupt masked (default) 1 : Interrupt unmasked
			6	MASK_GPIO3_F	0	RW	0 : Interrupt masked (default) 1 : Interrupt unmasked
			5	MASK_GPIO2_F	0	RW	0 : Interrupt masked (default) 1 : Interrupt unmasked
			4	MASK_GPIO1_F	0	RW	0 : Interrupt masked (default) 1 : Interrupt unmasked
			3	Reserved	0	RW	Reserved
			2	MASK_GPIO3_R	0	RW	0 : Interrupt masked (default) 1 : Interrupt unmasked
			1	MASK_GPIO2_R	0	RW	0 : Interrupt masked (default) 1 : Interrupt unmasked
			0	MASK_GPIO1_R	0	RW	0 : Interrupt masked (default) 1 : Interrupt unmasked
0xA7	1	RT_MASK9	7:5	Reserved	000	RW	Reserved
			4	MASK_VBUS_RC3	0	RW	0 : Interrupt masked (default) 1 : Interrupt unmasked
			3	MASK_VBUS_RC2	0	RW	0 : Interrupt masked (default) 1 : Interrupt unmasked
			2	MASK_VBUS_RC1	0	RW	0 : Interrupt masked (default) 1 : Interrupt unmasked
			1	MASK_VBUS_OC3	0	RW	0 : Interrupt masked (default) 1 : Interrupt unmasked
			0	MASK_VBUS_OC2	0	RW	0 : Interrupt masked (default) 1 : Interrupt unmasked
0xA8	1	RT_INT8	7	INT_BGOK_CHG	0	RW	0 : No action (default) 1 : BGOK Status change
			6	INT_GPIO3_F	0	RW	0 : No action (default) 1 : GPIO3 falling
			5	INT_GPIO2_F	0	RW	0 : No action (default) 1 : GPIO2 falling
			4	INT_GPIO1_F	0	RW	0 : No action (default) 1 : GPIO1 falling
			3	Reserved	0	RW	Reserved
			2	INT_GPIO3_R	0	RW	0 : No action (default) 1 : GPIO3 rising
			1	INT_GPIO2_R	0	RW	0 : No action (default) 1 : GPIO2 rising
			0	INT_GPIO1_R	0	RW	0 : No action (default) 1 : GPIO1 rising

Address	Length	Register Name	Bit	Bit Name	Default	Type	Description
0xA9	1	RT_INT9	7:5	Reserved	000	RW	Reserved
			4	INT_VBUS_RC3	0	RW	0 : No action (default) 1 : VBUS RCP3 occur Note : This bit can only be cleared when VBUS RCP3 event disappear
			3	Reserved	0	RW	Reserved
			2	INT_VBUS_RC1	0	RW	0 : No action (default) 1 : VBUS RCP1 occur Note : This bit can only be cleared when VBUS RCP1 event disappear
			1	INT_VBUS_OC3	0	RW	0 : No action (default) 1 : VBUS OCP3 occur Note : This bit can only be cleared when VBUS OCP3 event disappear
			0	INT_VBUS_OC2	0	RW	0 : No action (default) 1 : VBUS OCP2 occur Note : This bit can only be cleared when VBUS OCP2 event disappear
0xAA	1	RT_ST8	7	BGOK	0	R	BGOK status 0 : BG not ok (default) 1 : BG ok
			6	GPIO3_I	0	R	GPIO3 input data 0 : Input low (default) 1 : Input high
			5	GPIO2_I	0	R	GPIO2 input data 0 : Input low (default) 1 : Input high
			4	GPIO1_I	0	R	GPIO1 input data 0 : Input low (default) 1 : Input high
			3	Reserved	0	R	Reserved
			2	GPIO3_I	0	R	GPIO3 input data 0 : Input low (default) 1 : Input high
			1	GPIO2_I	0	R	GPIO2 input data 0 : Input low (default) 1 : Input high
			0	GPIO1_I	0	R	GPIO1 I input data 0 : Input low (default) 1 : Input high

Address	Length	Register Name	Bit	Bit Name	Default	Type	Description
0xAB	1	RT_ST9	7:5	Reserved	000	R	Reserved
			4	VBUS_RC3	0	R	VBUS RCP3 flag 0 : No VBUS RCP3 event occur (default) 1 : VBUS RCP3 occur
			3	Reserved	0	R	Reserved
			2	VBUS_RC1	0	R	VBUS RCP1 flag 0 : No VBUS RCP1 event occur (default) 1 : VBUS RCP1 occur
			1	VBUS_OC3	0	R	VBUS OCP3 flag 0 : No VBUS OCP3 event occur (default) 1 : VBUS OCP3 occur
			0	VBUS_OC2	0	R	VBUS OCP2 flag 0 : No VBUS OCP2 event occur (default) 1 : VBUS OCP2 occur
0xAF	1	TIMER_CTRL	7	TIMER_EN	0	RW	Timer enable 0 : Disable (default) 1 : Enable
			6:4	Reserved	000	R	Reserved
			3:0	TIMER_SEL	1011	RW	Timer count select 0000 : 0.4s 0001 : 0.8s ... 1011 : 4.8s (default) ... 1110 : 6.0s 1111 : 6.4s
0xB0	1	SYS_CTRL3	7:1	Reserved	0000000	R	Reserved
			0	SOFT_RESET	0	W	When writing 1b to this bit, it will trigger soft-reset event, and all register setting will reset to default value.
0xB2	1	TCPC_CTRL2	7:4	Reserved	0000	R	Reserved
			3:0	TDRP	0011	RW	The period a DRP will complete a Source to Sink and back advertisement. (Period = TDRP * 6.4 + 51.2ms) 0000 : 51.2ms 0001 : 57.6ms 0010 : 64ms 0011 : 70.4ms (default) ... 1110 : 140.8ms 1111 : 147.2ms

Address	Length	Register Name	Bit	Bit Name	Default	Type	Description
0xB3	1	TCPC_CTRL3	7:0	DCSRCDRP [7:0]	01000111	RW	The percent of time that a DRP will advertise Source during tDRP. (DUTY = (DCSRCDRP[9:0] + 1) / 1024) 0000000000 : 1/1024 0000000001 : 2/1024 ... 0101000111 : 328/1024 (default) ... 1111111110 : 1023/1024 1111111111 : 1024/1024 Note : Setting with 0xB4[9:8]
0xB4	1	TCPC_CTRL4	7:2	Reserved	000000	R	Reserved
			1:0	DCSRCDRP [9:8]	01	RW	The percent of time that a DRP will advertise Source during tDRP. (DUTY = (DCSRCDRP[9:0] + 1) / 1024) 0000000000 : 1/1024 0000000001 : 2/1024 ... 0101000111 : 328/1024 (default) ... 1111111110 : 1023/1024 1111111111 : 1024/1024 Note : Setting with 0xB4[9:8]
0xB5	1	TCPC_CTRL5	7:4	VBUS_DISCHARGE_TIME	0111	RW	Time for VBUS force/auto discharge 0000 : 6.4ms 0001 : 12.8ms 0010 : 19.2ms 0011 : 25.6ms 0100 : 32ms 0101 : 38.4ms 0110 : 44.8ms 0111 : 51.2ms (default) 1000 : 76.8ms 1001 : 102.4ms 1010 : 153.6ms 1011 : 204.8ms 1100 : 307.2ms 1101 : 409.6ms 1110 : 524.8ms 1111 : 652.8ms
			3:0	Reserved	0000	R	Reserved

Address	Length	Register Name	Bit	Bit Name	Default	Type	Description
0xB6	1	TCPC_CTRL6	7:0	TPDDEBOUNCE	10010110	RW	<p>PD Debounce Time a Sink port shall wait before it can determine it is detached. (tPDDebounce time = TPDDEBOUNCE * 0.1ms)</p> <p>00000000 : Reserved 00000001 : Reserved 00000010 : 0.2ms ... 10010110 : 15ms (default) ... 11111110 : 25.4ms 11111111 : 25.5ms</p>
0xB7	1	TCPC_CTRL7	7:0	TCCDEBOUNCE	10111100	RW	<p>CC Debounce Time a port shall wait before it can determine it is attached. (tCCDebounce time = TCCDEBOUNCE * 0.8ms)</p> <p>00000000 : Reserved 00000001 : Reserved 00000010 : 1.6ms ... 10111100 : 150.4ms (default) ... 11111110 : 203.2ms 11111111 : 204.0ms</p>
0xB8	1	SYS_CTRL4	7:0	RTINI_REG90	00000000	RW	<p>Pre-determined low power mode setting (0x90) for open Source TCPM to enter low power mode when unattached.</p> <p>RT2 0x10[1:0] == 2'b01 : TCPM writes 0x1A[6] = 1 will auto update 0x90 = RTINI_REG90.</p> <p>RT2 0x10[1:0] == 2'b10 : TCPM writes 0x1A will auto update 0x90 = RTINI_REG90 while CCx_STATUS is open or single RA only.</p> <p>RT2 0x10[1:0] == 2'b11 : TCPM writes 0x1A will auto update 0x90 = RTINI_REG90 while CCx_STATUS is open.</p> <p>RT2 0x10[1:0] == 2'b00 : No auto update 0x90 = RTINI_REG90</p>

Address	Length	Register Name	Bit	Bit Name	Default	Type	Description
0xBE	1	WATCHDOG_CTRL	7:4	Reserved	0000	RW	Reserved
			3:0	WATCHDOG_SEL	1011	RW	The watchdog timer shall start when any of the interrupts that are not masked in the Alert register is set or when the IRQB pin is asserted. (watchdog timeout time = (WATCHDOG_SEL + 1) * 0.4sec) 0000 : 0.4s 0001 : 0.8s ... 1011 : 4.8s (default) ... 1110 : 6.0s 1111 : 6.4s
0xBF	1	I2C_TO_RST_CTRL	7	I2C_TO_RST_EN	0	RW	Set this bit to 1b to enable I ² C reset timer. When I ² C reset timer is enabled, it will monitor SCL and SDA. When SCL and SDA both keep low, I ² C reset timer will start to count. I ² C reset timer will be cleared to 0 when SCL or SDA becomes high. When I ² C reset timer gets timeout, it will trigger soft reset event and all registers will be reset to default value. 0 : Disable I ² C reset timer (default) 1 : Enable I ² C reset timer
			6:4	Reserved	000	RW	Reserved
			3:0	I2C_TO_RST_SEL	1000	RW	Timeout time for I ² C reset timer (timeout time = (I2C_TO_RST_SEL+1) * 12.5ms) 0000 : 12.5ms 0001 : 25.0ms ... 1000 : 112.5ms (default) ... 1111 : 200ms
0xC8	1	HILO_CTRL9	7:5	VREF_VBUS_VALID	000	RW	VBUS_VALID threshold : 2.6V to 4.0V, LSB = 0.2V 000 : 2.6V (default) 001 : 2.8V ... 110 : 3.8V 111 : 4.0V
			4:0	Reserved	00000	RW	Reserved

Address	Length	Register Name	Bit	Bit Name	Default	Type	Description
0xCA	1	SHILED_CTRL1	7:2	Reserved	101000	RW	Reserved
			1	CTD_EN	1	RW	Set this bit to 1b to enable auto cable type detection. For auto cable type detection, it will check the cable is Type-C or Type-A every time after cable plug-in when CC act as Sink. 0 : Disable auto cable type detection 1 : Enable auto cable type detection (default)
			0	Reserved	1	RW	Reserved
0xCB	1	FRS_CTRL1	7:4	FRSWAPRX	1100	RW	Initial sink detects FRS Tx signal for at least this amount of time. 3.125μs per step (32k). 0000 : 0μs 0001 : 3.125μs ... 1100 : 37.5μs (default) ... 1111 : 46.875μs
			3:2	VREF_RX_FRS	10	RW	Fast role-swap detection threshold on CC pin 00 : 0.48V 01 : 0.50V 10 : 0.52V (default) 11 : 0.54V
			1:0	Reserved	00	R	Reserved
0xCC	1	FRS_CTRL2	7	Reserved	0	RW	Reserved
			6	RX_FRS_EN	0	RW	Fast-role swap rx detection enable 0 : Disable (default) 1 : Enable
			5	Reserved	0	RW	Reserved
			4	FR_VBUS_SELECT	1	RW	FR_VBUS_FLAG is de-bounced or not. 0 : Not de-bounce FR_VBUS_VALID 1 : De-bounce FR_VBUS_VALID (default)
			3	VBUS_FRS_EN	0	RW	VBUS Fast role-swap detection enable 0 : Disable (default) 1 : Enable
			2:0	VREF_VBUS_FRS	000	RW	VBUS fast role-swap detection threshold selection 000 : 4.8V (default) 001 : 4.9V 010 : 5.0V 011 : 5.1V 100 : 5.2V 101 : 5.3V 110 : 5.4V 111 : 5.5V

Address	Length	Register Name	Bit	Bit Name	Default	Type	Description
0xCE	1	FRS_CTRL3	7:4	Reserved	0000	R	Reserved
			3	FRS_RX_WAIT_GPIO2	0	RW	GPIO2 reload when receive fast role swap event 0 : Reload setting when receive fast role swap event (default) 1 : Reload setting when receive fast role swap event and VBUS < VREF_VBUS_FRS
			2	FRS_RX_WAIT_GPIO1	0	RW	GPIO1 reload when receive fast role swap event 0 : Reload setting when receive fast role swap event (default) 1 : Reload setting when receive fast role swap event and VBUS < VREF_VBUS_FRS
			1	FRS_RX_WAIT_GPB	0	RW	GPB reload when receive fast role swap event 0 : Reload setting when receive fast role swap event (default) 1 : Reload setting when receive fast role swap event and VBUS < VREF_VBUS_FRS
			0	FRS_RX_WAIT_GPA	0	RW	GPA reload when receive fast role swap event 0 : Reload setting when receive fast role swap event (default) 1 : Reload setting when receive fast role swap event and VBUS < VREF_VBUS_FRS
0xDD	1	VBUS_PATH_CTRL	7:4	GPB_CTRL	1000	RW	Path control for GPB 0000 : Pull-down with 50μA 0001 : Pull-down with 250μA 0010 : Pull-down with 8kΩ 0011 : Pull-down with 200μA 01x0 : Pull-up with 50μA 01x1 : Pull-up with 200μA 1xxx : Floating (default)
			3:0	GPA_CTRL	1000	RW	Path control for GPA 0000 : Pull-down with 50μA 0001 : Pull-down with 250μA 0010 : Pull-down with 8kΩ 0011 : Pull-down with 200μA 01x0 : Pull-up with 50μA 01x1 : Pull-up with 200μA 1xxx : Floating (default)

Address	Length	Register Name	Bit	Bit Name	Default	Type	Description
0xDE	1	DIS_SNK_VBUS_CTRL	7:4	DIS_SNK_VBUS_GPB	1000	RW	Path control for GPB when receiving TCPM disable sink VBUS command (0x23 = 44h) 0000 : Pull-down with 50μA 0001 : Pull-down with 250μA 0010 : Pull-down with 8kΩ 0011 : Pull-down with 200μA 01x0 : Pull-up with 50μA 01x1 : Pull-up with 200μA 1xxx : Floating (default)
			3:0	DIS_SNK_VBUS_GPA	1000	RW	Path control for GPA when receiving TCPM disable sink VBUS command (0x23 = 44h) 0000 : Pull-down with 50μA 0001 : Pull-down with 250μA 0010 : Pull-down with 8kΩ 0011 : Pull-down with 200μA 01x0 : Pull-up with 50μA 01x1 : Pull-up with 200μA 1xxx : Floating (default)
0xDF	1	ENA_SNK_VBUS_CTRL	7:4	ENA_SNK_VBUS_GPB	1000	RW	Path control for GPB when receiving TCPM enable sink VBUS command (0x23 = 55h) 0000 : Pull-down with 50μA 0001 : Pull-down with 250μA 0010 : Pull-down with 8kΩ 0011 : Pull-down with 200μA 01x0 : Pull-up with 50μA 01x1 : Pull-up with 200μA 1xxx : Floating (default)
			3:0	ENA_SNK_VBUS_GPA	1000	RW	Path control for GPA when receiving TCPM enable sink VBUS command (0x23 = 55h) 0000 : Pull-down with 50μA 0001 : Pull-down with 250μA 0010 : Pull-down with 8kΩ 0011 : Pull-down with 200μA 01x0 : Pull-up with 50μA 01x1 : Pull-up with 200μA 1xxx : Floating (default)

Address	Length	Register Name	Bit	Bit Name	Default	Type	Description
0xE0	1	DIS_SRC_VBUS_CTRL	7:4	DIS_SRC_VBUS_GPB	1000	RW	Path control for GPB when receiving TCPM disable source VBUS command (0x23 = 66h) 0000 : Pull-down with 50μA 0001 : Pull-down with 250μA 0010 : Pull-down with 8kΩ 0011 : Pull-down with 200μA 01x0 : Pull-up with 50μA 01x1 : Pull-up with 200μA 1xxx : Floating (default)
			3:0	DIS_SRC_VBUS_GPA	1000	RW	Path control for GPA when receiving TCPM disable SINK VBUS command (0x23 = 66h) 0000 : Pull-down with 50μA 0001 : Pull-down with 250μA 0010 : Pull-down with 8kΩ 0011 : Pull-down with 200μA 01x0 : Pull-up with 50μA 01x1 : Pull-up with 200μA 1xxx : Floating (default)
0xE1	1	ENA_SRC_VBUS_CTRL	7:4	ENA_SRC_VBUS_GPB	1000	RW	Path control for GPB when receiving TCPM enable source VBUS command (0x23 = 77h) 0000 : Pull-down with 50μA 0001 : Pull-down with 250μA 0010 : Pull-down with 8kΩ 0011 : Pull-down with 200μA 01x0 : Pull-up with 50μA 01x1 : Pull-up with 200μA 1xxx : Floating (default)
			3:0	ENA_SRC_VBUS_GPA	1000	RW	Path control for GPA when receiving TCPM enable source VBUS command (0x23 = 77h) 0000 : Pull-down with 50μA 0001 : Pull-down with 250μA 0010 : Pull-down with 8kΩ 0011 : Pull-down with 200μA 01x0 : Pull-up with 50μA 01x1 : Pull-up with 200μA 1xxx : Floating (default)

Address	Length	Register Name	Bit	Bit Name	Default	Type	Description
0xE2	1	ENA_SRC_HV_VBUS_CTRL	7:4	ENA_SRC_HV_VBUS_GPB	1000	RW	Path control for GPB when receiving enable source HV VBUS command (0x23 = 88h) 0000 : Pull-down with 50μA 0001 : Pull-down with 250μA 0010 : Pull-down with 8kΩ 0011 : Pull-down with 200μA 01x0 : Pull-up with 50μA 01x1 : Pull-up with 200μA 1xxx : Floating (default)
			3:0	ENA_SRC_HV_VBUS_GPA	1000	RW	Path control for GPA when receiving enable source HV VBUS command (0x23 = 88h) 0000 : Pull-down with 50μA 0001 : Pull-down with 250μA 0010 : Pull-down with 8kΩ 0011 : Pull-down with 200μA 01x0 : Pull-up with 50μA 01x1 : Pull-up with 200μA 1xxx : Floating (default)
0xE3	1	FAULT_OC1_VBUS_CTRL	7:4	FAULT_OC1_VBUS_GPB	1000	RW	Path control for GPB when VBUS OC1 occurred 0000 : Pull-down with 50μA 0001 : Pull-down with 250μA 0010 : Pull-down with 8kΩ 0011 : Pull-down with 200μA 01x0 : Pull-up with 50μA 01x1 : Pull-up with 200μA 1xxx : Floating (default)
			3:0	FAULT_OC1_VBUS_GPA	1000	RW	Path control for GPA when VBUS OC1 occurred 0000 : Pull-down with 50μA 0001 : Pull-down with 250μA 0010 : Pull-down with 8kΩ 0011 : Pull-down with 200μA 01x0 : Pull-up with 50μA 01x1 : Pull-up with 200μA 1xxx : Floating (default)

Address	Length	Register Name	Bit	Bit Name	Default	Type	Description
0xE4	1	FAULT_OC2_VBUS_CTRL	7:4	FAULT_OC2_VBUS_GPB	1000	RW	Path control for GPB when VBUS OC2 occurred 0000 : Pull-down with 50μA 0001 : Pull-down with 250μA 0010 : Pull-down with 8kΩ 0011 : Pull-down with 200μA 01x0 : Pull-up with 50μA 01x1 : Pull-up with 200μA 1xxx : Floating (default)
			3:0	FAULT_OC2_VBUS_GPA	1000	RW	Path control for GPA when VBUS OC2 occurred 0000 : Pull-down with 50μA 0001 : Pull-down with 250μA 0010 : Pull-down with 8kΩ 0011 : Pull-down with 200μA 01x0 : Pull-up with 50μA 01x1 : Pull-up with 200μA 1xxx : Floating (default)
0xE5	1	FAULT_OC3_VBUS_CTRL	7:4	FAULT_OC3_VBUS_GPB	1000	RW	Path control for GPB when VBUS OC3 occurred 0000 : Pull-down with 50μA 0001 : Pull-down with 250μA 0010 : Pull-down with 8kΩ 0011 : Pull-down with 200μA 01x0 : Pull-up with 50μA 01x1 : Pull-up with 200μA 1xxx : Floating (default)
			3:0	FAULT_OC3_VBUS_GPA	1000	RW	Path control for GPA when VBUS OC3 occurred 0000 : Pull-down with 50μA 0001 : Pull-down with 250μA 0010 : Pull-down with 8kΩ 0011 : Pull-down with 200μA 01x0 : Pull-up with 50μA 01x1 : Pull-up with 200μA 1xxx : Floating (default)

Address	Length	Register Name	Bit	Bit Name	Default	Type	Description
0xE6	1	FAULT_OV_VBUS_CTRL	7:4	FAULT_OV_VBUS_GPB	1000	RW	Path control for GPB when VBUS OV occurred 0000 : Pull-down with 50μA 0001 : Pull-down with 250μA 0010 : Pull-down with 8kΩ 0011 : Pull-down with 200μA 01x0 : Pull-up with 50μA 01x1 : Pull-up with 200μA 1xxx : Floating (default)
			3:0	FAULT_OV_VBUS_GPA	1000	RW	Path control for GPA when VBUS OV occurred 0000 : Pull-down with 50μA 0001 : Pull-down with 250μA 0010 : Pull-down with 8kΩ 0011 : Pull-down with 200μA 01x0 : Pull-up with 50μA 01x1 : Pull-up with 200μA 1xxx : Floating (default)
0xE7	1	FAULT_RC_VBUS_CTRL	7:4	FAULT_RC_VBUS_GPB	1000	RW	Path control for GPB when VBUS RC occurred 0000 : Pull-down with 50μA 0001 : Pull-down with 250μA 0010 : Pull-down with 8kΩ 0011 : Pull-down with 200μA 01x0 : Pull-up with 50μA 01x1 : Pull-up with 200μA 1xxx : Floating (default)
			3:0	FAULT_RC_VBUS_GPA	1000	RW	Path control for GPA when VBUS RC occurred 0000 : Pull-down with 50μA 0001 : Pull-down with 250μA 0010 : Pull-down with 8kΩ 0011 : Pull-down with 200μA 01x0 : Pull-up with 50μA 01x1 : Pull-up with 200μA 1xxx : Floating (default)

Address	Length	Register Name	Bit	Bit Name	Default	Type	Description
0xE9	1	FRS_RX_VBUS_CTRL	7:4	FRS_RX_VBUS_GPB	1000	RW	Path control for GPB when receiving fast role swap event 0000 : Pull-down with 50μA 0001 : Pull-down with 250μA 0010 : Pull-down with 8kΩ 0011 : Pull-down with 200μA 01x0 : Pull-up with 50μA 01x1 : Pull-up with 200μA 1xxx : Floating (default)
			3:0	FRS_RX_VBUS_GPA	1000	RW	Path control for GPA when receiving fast role swap event 0000 : Pull-down with 50μA 0001 : Pull-down with 250μA 0010 : Pull-down with 8kΩ 0011 : Pull-down with 200μA 01x0 : Pull-up with 50μA 01x1 : Pull-up with 200μA 1xxx : Floating (default)
0xEA	1	GPIO1_VBUS_CTRL	7	Reserved	0	R	Reserved
			6	FRS_RX_VBUS_GPIO1	0	RW	Path control for GPIO1 when receiving fast role swap event 0 : push-pull output 0 (default) 1 : push-pull output 1
			5	Reserved	0	R	Reserved
			4	ENA_SRC_HV_VBUS_GPIO1	0	RW	Path control for GPIO1 when receiving enable source HV VBUS command (0x23 = 88h) 0 : Push-pull output 0 (default) 1 : Push-pull output 1
			3	ENA_SRC_VBUS_GPIO1	0	RW	Path control for GPIO1 when receiving TCPM enable source VBUS command (0x23 = 77h) 0 : Push-pull output 0 (default) 1 : Push-pull output 1
			2	DIS_SRC_VBUS_GPIO1	0	RW	Path control for GPIO1 when receiving TCPM disable source VBUS command (0x23 = 66h) 0 : Push-pull output 0 (default) 1 : Push-pull output 1
			1	ENA_SNK_VBUS_GPIO1	0	RW	Path control for GPIO1 when receiving TCPM enable sink VBUS command (0x23 = 55h) 0 : Push-pull output 0 (default) 1 : Push-pull output 1
			0	DIS_SNK_VBUS_GPIO1	0	RW	Path control for GPIO1 when receiving TCPM disable sink VBUS command (0x23 = 44h) 0 : Push-pull output 0 (default) 1 : Push-pull output 1

Address	Length	Register Name	Bit	Bit Name	Default	Type	Description
0xEB	1	GPIO2_VBUS_CTRL	7	Reserved	0	R	Reserved
			6	FRS_RX_VBUS_GPIO2	0	RW	Path control for GPIO2 when receiving fast role swap event 0 : Push-pull output 0 (default) 1 : Push-pull output 1
			5	Reserved	0	R	Reserved
			4	ENA_SRC_HV_VBUS_GPIO2	0	RW	Path control for GPIO2 when receiving enable source HV VBUS command (0x23 = 88h) 0 : Push-pull output 0 (default) 1 : Push-pull output 1
			3	ENA_SRC_VBUS_GPIO2	0	RW	Path control for GPIO2 when receiving TCPM enable source VBUS command (0x23 = 77h) 0 : Push-pull output 0 (default) 1 : Push-pull output 1
			2	DIS_SRC_VBUS_GPIO2	0	RW	Path control for GPIO2 when receiving TCPM disable source VBUS command (0x23 = 66h) 0 : Push-pull output 0 (default) 1 : Push-pull output 1
			1	ENA_SNK_VBUS_GPIO2	0	RW	Path control for GPIO2 when receiving TCPM enable sink VBUS command (0x23 = 55h) 0 : Push-pull output 0 (default) 1 : Push-pull output 1
			0	DIS_SNK_VBUS_GPIO2	0	RW	Path control for GPIO2 when receiving TCPM disable sink VBUS command (0x23 = 44h) 0 : Push-pull output 0 (default) 1 : Push-pull output 1

Address	Length	Register Name	Bit	Bit Name	Default	Type	Description
0xEC	1	VBUS_CTRL_EN	7	GPIO2_VBUS_PATH_EN	0	RW	GPIO2 setting (GPIO2_OD_N/GPIO2_OE/GPIO2_O) auto reload with TCPC command and FRS event 0 : GPIO2 setting (GPIO2_OD_N/GPIO2_OE/GPIO2_O) will not auto reload (default) 1 : GPIO2 setting (GPIO2_OD_N/GPIO2_OE/GPIO2_O) will auto reload
			6	GPIO1_VBUS_PATH_EN	0	RW	GPIO1 setting (GPIO1_OD_N/GPIO1_OE/GPIO1_O) auto reload with TCPC command and FRS event 0 : GPIO1 setting (GPIO1_OD_N/GPIO1_OE/GPIO1_O) will not auto reload (default) 1 : GPIO1 setting (GPIO1_OD_N/GPIO1_OE/GPIO1_O) will auto reload
			5	GPB_VBUS_PATH_EN	1	RW	GPB setting (GPB_CTRL) auto reload with TCPC command, VBUS OV/OC/RC event, and FRS event 0 : GPB setting (GPB_CTRL) will not auto reload 1 : GPB setting (GPB_CTRL) will auto reload (default)
			4	GPA_VBUS_PATH_EN	1	RW	GPA setting (GPA_CTRL) auto reload with TCPC command, VBUS OV/OC/RC event, and FRS event 0 : GPA setting (GPA_CTRL) will not auto reload 1 : GPA setting (GPA_CTRL) will auto reload (default)
			3	VBUS_CPGPB_AUTO_OFF	1	RW	Auto disable VBUS Charge-pump for GPB when in low power mode 0 : Not auto disable 1 : Auto disable when in low power mode (default)
			2	VBUS_CPGPA_AUTO_OFF	1	RW	Auto disable VBUS Charge-pump for GPA when in low power mode 0 : Not auto disable 1 : Auto disable when in low power mode (default)
			1	VBUS_CPGPB_EN	1	RW	VBUS charge-pump for GPB 0 : Disable 1 : Enable (default)
			0	VBUS_CPGPA_EN	1	RW	VBUS charge-pump for GPA 0 : Disable 1 : Enable (default)

Address	Length	Register Name	Bit	Bit Name	Default	Type	Description
0xED	1	GPIO1_CTRL	7	GPIO1_DG_EN	0	RW	Deglintch for GPIO1 input 0 : No deglitch (default) 1 : Enable deglitch (3μs)
			6	GPIO1_SMT	0	RW	GPIO1 enable input data detection with Schmitter trigger hysteresis 0 : Disable (default) 1 : Enable
			5	GPIO1_PU	0	RW	GPIO1 internal pull-high enable 0 : Disable (default) 1 : Enable
			4	GPIO1_PD	0	RW	GPIO1 internal pull-low enable 0 : Disable (default) 1 : Enable
			3	GPIO1_OD_N	0	RW	GPIO1 push-pull/open-drain select 0 : Open-drain (default) 1 : Push-pull
			2	GPIO1_OE	0	RW	GPIO1 output data enable 0 : GPIO1 as input (default) 1 : GPIO1 as output
			1	GPIO1_O	0	RW	GPIO1 output data 0 : GPIO1 output low (default) 1 : GPIO1 output high
			0	GPIO1_I	0	R	GPIO1 input data 0 : Input low (default) 1 : Input high

Address	Length	Register Name	Bit	Bit Name	Default	Type	Description
0xEE	1	GPIO2_CTRL	7	GPIO2_DG_EN	0	RW	Deglintch for GPIO2 input 0 : no deglintch (default) 1 : enable deglintch (3 μ s)
			6	GPIO2_SMT	0	RW	GPIO2 enable Input data detection with Schmitter trigger hysteresis 0 : Disable (default) 1 : Enable
			5	GPIO2_PU	0	RW	GPIO2 internal pull-high enable 0 : Disable (default) 1 : Enable
			4	GPIO2_PD	0	RW	GPIO2 internal pull-low enable 0 : Disable (default) 1 : Enable
			3	GPIO2_OD_N	0	RW	GPIO2 push-pull/open-drain select 0 : Open-drain (default) 1 : Push-pull
			2	GPIO2_OE	0	RW	GPIO2 output data enable 0 : GPIO2 as input (default) 1 : GPIO2 as output
			1	GPIO2_O	0	RW	GPIO2 output data 0 : GPIO2 output low (default) 1 : GPIO2 output high
			0	GPIO2_I	0	R	GPIO2 input data 0 : Input low (default) 1 : Input high

Address	Length	Register Name	Bit	Bit Name	Default	Type	Description
0xEF	1	GPIO3_CTRL	7	GPIO3_DG_EN	0	RW	Deglintch for GPIO3 input 0 : No deglitch (default) 1 : Enable deglitch (3us)
			6	GPIO3_SMT	0	RW	GPIO3 enable Input data detection with Schmitter trigger hysteresis 0 : Disable (default) 1 : Enable
			5	GPIO3_PU	0	RW	GPIO3 internal pull-high enable 0 : Disable (default) 1 : Enable
			4	GPIO3_PD	0	RW	GPIO3 internal pull-low enable 0 : Disable (default) 1 : Enable
			3	GPIO3_OD_N	0	RW	GPIO3 Push-pull/open-drain select 0 : open-drain (default) 1 : push-pull
			2	GPIO3_OE	0	RW	GPIO3 output data enable 0 : GPIO3 as input (default) 1 : GPIO3 as output
			1	GPIO3_O	0	RW	GPIO3 output data 0 : GPIO3 output low (default) 1 : GPIO3 output high
			0	GPIO3_I	0	R	GPIO3 input data 0 : Input low (default) 1 : Input high
0xF2	1	RT2_PAGE	7:0	RT2_PAGE	0x00	RW	Access port to RT2 PAGE

Page 2 of Register Table

Address	Length	Register Name	Bit	Bit Name	Default	Type	Description
0x10	1	SYS_CTRL5	7	FOD_DISLMT_EN	1	RW	Enable FOD discharge current limit. 0 : Disable 1 : Enable (default)
			6	LPWR_DRP_ROLE	0	RW	Option to apply LPRW_RPD_CCx (when not toggling) or Toggling Roles(when toggling) to CCx when enabling LPWR DRP and during setup states (st_off, st_start) or stop states (st_stop). When option is offed, LPWR DRP will present CCx open during setup states and stop states. 0 : Disable (default) 1 : Enable
			5:4	AUTO_LPWR_TIMEOUT	00	RW	These bits can be used to set the time before entering into auto low power. 00 : 1.0s (default) 01 : 1.5s 10 : 2.0s 11 : 2.5s
			3	AUTO_OSC_24M_EN	0	RW	Option to auto enable 0x90[0] when IRQB = low. 0 : Disable (default) 1 : Enable
			2:0	AUTO_LPWR_EN	000	RW	For open Source TCPM to enter low power mode when unattached. Auto write low power control register per below scenario. 000 : Disable (default) 100 : HW auto update 0x90 = RTINI_REG90 when reach auto low power timeout. Auto low power timer is enabled when TCPC is in normal mode with CCx_Status are both opened and no IRQB Event and VBUS_PRESENT = 0. 101 : HW auto update 0x90 = RTINI_REG90 when reach auto low power timeout. Auto low power timer is enabled when TCPC is in normal mode with CCx_Status are both opened for Sink or CCx_Status has single RA for Source and no IRQB Event and VBUS_PRESENT = 0. 110/111 : Disable The other settings are reserved.

Address	Length	Register Name	Bit	Bit Name	Default	Type	Description
0x11	1	VCON_CTRL4	7:6	Reserved	00	R	Reserved
			5	VCONN_UVP_CP_EN	1	RW	VCONN_INVALID_FLAG action selection : 0 : After VCONN INVALID, wait digital turn-off VCONN_EN 1 : After VCONN INVALID, VCONN_INVALID_FLAG directly turn-off VCONN_EN (default)
			4	VCONN_OCP_CP_EN	1	RW	VCONN_OCP_FLAG action selection: 0 : After VCONN OCP, wait digital turn-off VCONN_EN 1 : After VCONN OCP, VCONN_OCP_FLAG directly turn-off VCONN_EN (default)
			3:2	Reserved	00	R	Reserved
			1	CMPEN_VBUS_TO_CC2	0	RW	CC2 short to VBUS detection, trigger voltage is 3 x 1.15 = 3.45V 0 : Disable (default) 1 : Enable
			0	CMPEN_VBUS_TO_CC1	0	RW	CC1 short to VBUS detection, trigger voltage is 3 x 1.15 = 3.45V 0 : Disable (default) 1 : Enable
			0x12	1	VDC_CTRL	7:6	Reserved
5:4	VDC_VOL	00				RW	VDC under-voltage level select 00 : 0.55V (default) 01 : 0.9V 10 : 1.5V 11 : 2.0V
3:1	Reserved	000				R	Reserved
0	VDC_DET_EN	0				RW	VDC detection enable 0 : Disable 1 : Enable

Address	Length	Register Name	Bit	Bit Name	Default	Type	Description
0x13	1	VBUS_VOL_CTRL	7	Reserved	0	R	Reserved
			6	VBUS_OVP_NODEB	0	RW	VBUS OVP no debounce 0 : VBUS OVP has 25µs deglitch (default) 1 : VBUS OVP no debounce/deglitch
			5:4	VBUS_OVP_SEL	10	RW	VBUS Over Voltage Protection level percentage. OVP = VBUS x (100+X)% 00 : X = 5 01 : X = 10 10 : X = 15 (default) 11 : X = 20
			3:0	VBUS_VOL_SEL	1000	RW	VBUS voltage range 0000 : 5V 0001 : 6V 1000 : 13V (default) 1110 : 19V 1111 : 20V
0x14	1	VBUS_OCRC_EN	7:5	Reserved	000	R	Reserved
			4	VBUS_OCRC3_EN	0	RW	VBUS OCP3/RCP3 enable 0 : Disable (default) 1 : Enable
			3	Reserved	0	R	Reserved
			2	VBUS_RCP1_EN	0	RW	VBUS RCP1 enable 0 : Disable (default) 1 : Enable
			1	VBUS_OCP2_EN	0	RW	VBUS OCP2 enable 0 : Disable (default) 1 : Enable
			0	VBUS_OCP1_EN	1	R	VBUS OCP1 enable 0 : Disable 1 : Enable (VBUS_OCP1_EN is from TCPC's OCP_EN reg 0x1B) (default)

Address	Length	Register Name	Bit	Bit Name	Default	Type	Description
0x15	1	VBUS_OCRC_STS	7	Reserved	0	R	Reserved
			6	VBUS_RCP3_STS	0	R	VBUS RCP3 status 0 : Not RCP3 occur (default) 1 : RCP3 occur
			5	Reserved	0	R	Reserved
			4	VBUS_RCP1_STS	0	R	VBUS RCP1 status 0 : Not RCP1 occur (default) 1 : RCP1 occur
			3	Reserved	0	R	Reserved
			2	VBUS_OCP3_STS	0	R	VBUS OCP3 status 0 : Not OCP3 occur (default) 1 : OCP3 occur
			1	VBUS_OCP2_STS	0	R	VBUS OCP2 status 0 : Not OCP2 occur (default) 1 : OCP2 occur
			0	VBUS_OCP1_STS	0	R	VBUS OCP1 status 0 : Not OCP1 occur (default) 1 : OCP1 occur
0x16	1	VBUS_OCP_CTRL1	7	Reserved	0	R	Reserved
			6:0	VBUS_OCP1_SEL	0100010	RW	VBUS OCP1 level selection 0000000 : 0.2A 0000001 : 0.3A 0100010 : 3.6A (default) 1111110 : 12.8A 1111111 : 12.9A
0x17	1	VBUS_OCP_CTRL2	7	Reserved	0	R	Reserved
			6:0	VBUS_OCP2_SEL	0100010	RW	VBUS OCP2 level selection 0000000 : 0.2A 0000001 : 0.3A 0100010 : 3.6A (default) 1111110 : 12.8A 1111111 : 12.9A
0x18	1	VBUS_OCP_CTRL3	7:2	Reserved	000000	R	Reserved
			1:0	VBUS_OCP3_SEL	10	RW	VBUS OCP3 level select 00 : 7.25A 01 : 9A 10 : 12A (default) 11 : 15A

Address	Length	Register Name	Bit	Bit Name	Default	Type	Description
0x19	1	VBUS_OCP_CTRL4	7	VBUS_OCP1_50MS	0	RW	VBUS OCP1 Timer Step 0 : 10ms/step(default) 1 : 50ms/Step
			6:0	VBUS_OCP1_TIME	1010000	RW	VBUS OCP1 detect time period When VBUS OCP detect over VBUS_OCP1_SEL and keep over this time period, VBUS_OCP interrupt will be trigger 0000000 : 0 step (trigger interrupt immediately when detect) 0000001 : 1 step (10 or 50ms) 0000010 : 2 step (20 or 100ms) ... 1010000 : 80 step (800 or 4000ms) (default) ... 1111111 : 127 step (1270 or 6350ms)
0x1A	1	VBUS_OCP_CTRL5	7	VBUS_OCP2_50MS	0	RW	VBUS OCP2 timer step 0 : 10ms/step (default) 1 : 50ms/Step
			6:0	VBUS_OCP2_TIME	1010000	RW	VBUS OCP2 detect time period When VBUS OCP detect over VBUS_OCP2_SEL and keep over this time period, VBUS_OCP interrupt will be trigger 0000000 : 0 step (trigger interrupt immediately when detect) 0000001 : 1 step (10 or 50ms) 0000010 : 2 step (20 or 100ms) ... 1010000 : 80 step (800 or 4000ms) (default) ... 1111111 : 127 step (1270 or 6350ms)
0x1B	1	VBUS_RCP_CTRL1	7	Reserved	0	R	Reserved
			6:0	VBUS_RCP1_SEL	0100010	RW	VBUS RCP1 level selection 0000000 : -0.2A 0000001 : -0.3A 0100010 : -3.6A(default) 1111110 : -12.8A 1111111 : -12.9A
0x1D	1	VBUS_RCP_CTRL3	7:2	Reserved	000000	R	Reserved
			1:0	VBUS_RCP3_SEL	10	RW	VBUS RCP3 level select 00 : 7.25A 01 : 9A 10 : 12A (default) 11 : 15A

Address	Length	Register Name	Bit	Bit Name	Default	Type	Description
0x1E	1	VBUS_RCP_CRTL4	7	VBUS_RCP1_50MS	0	RW	VBUS RCP1 timer step 0 : 10ms/step (default) 1 : 50ms/Step
			6:0	VBUS_RCP1_TIME	1010000	RW	VBUS RCP1 detect time period When VBUS RCP detect over VBUS_RCP1_SEL and keep over this time period, VBUS_RCP interrupt will be trigger 0000000 : 0 step (trigger interrupt immediately when detect) 0000001 : 1 step (10 or 50ms) 0000010 : 2 step (20 or 100ms) ... 1010000 : 80 step (800 or 4000ms) (default) ... 1111111 : 127 step (1270 or 6350ms)
0x1F	1	VBUS_RCP_CRTL5	7:1	Reserved	0000000	R	Reserved
			0	HL_VBUS_SEL_OC	0	RW	High/Low VBUS select for OC detection 0 : Low VBUS condition for OC detection (default) 1 : High VBUS condition for OC detection

Address	Length	Register Name	Bit	Bit Name	Default	Type	Description
0x36	1	PATH_TO_CTRL	7:4	Reserved	0000	RW	Reserved
			3	TO_EN_GP2	0	RW	GPIO2 TCPC Watchdog timeout reset to default enable 0 : Disable (GPIO2 not reset to default setting when TCPC watchdog timeout occur) (default) 1 : Enable (GPIO2 will reset to default setting when TCPC watchdog timeout occur)
			2	TO_EN_GP1	0	RW	GPIO1 TCPC Watchdog timeout reset to default enable 0 : Disable (GPIO1 not reset to default setting when TCPC watchdog timeout occur) (default) 1 : Enable (GPIO1 will reset to default setting when TCPC watchdog timeout occur)
			1	TO_EN_GPB	0	RW	GPB TCPC Watchdog timeout reset to default enable 0 : Disable (GPB not reset to default setting when TCPC watchdog timeout occur) (default) 1 : Enable (GPB will reset to default setting when TCPC watchdog timeout occur)
			0	TO_EN_GPA	0	RW	GPA TCPC Watchdog timeout reset to default enable 0 : Disable (GPA not reset to default setting when TCPC watchdog timeout occur) (default) 1 : Enable (GPA will reset to default setting when TCPC watchdog timeout occur)
0x37	1	OTP_CTRL	7:2	Reserved	000000	RW	Reserved
			1	OTP_VCON_OFF	0	RW	VCONN off when OTP occurred 0 : VCONN not off when OTP occurred (default) 1 : VCONN off when OTP occurred
			0	OTP_EN	0	RW	OTP protect enable 0 : Disable OTP protect(default) 1 : Enable OTP protect

Address	Length	Register Name	Bit	Bit Name	Default	Type	Description
0x3A	1	SBU_CTRL_01	7	SBU_VIEN	1	RW	SBU protection VI source enable 0 : Disable 1 : Enable (default)
			6	DPDM_VIEN	1	RW	DPDM protection VI source enable 0 : Disable 1 : Enable (default)
			5:4	Reserved	00	R	Reserved
			3	SBU2_SWEN	1	RW	SBU2 switch enable 0 : Disable 1 : Enable (default)
			2	SBU1_SWEN	1	RW	SBU1 switch enable 0 : Disable 1 : Enable (default)
			1	DM_SWEN	1	RW	DM switch enable 0 : Disable 1 : Enable (default)
			0	DP_SWEN	1	RW	DP switch enable 0 : Disable 1 : Enable (default)
0x3C	1	SBU_CTRL_03	7	DPDM_OV_DEG	0	RW	DPDM OVP deglitch 0 : Deglitch disable (default) 1 : Deglitch enable
			6	SBU_OV_DEG	0	RW	SBU OVP deglitch 0 : Deglitch disable (default) 1 : Deglitch enable
			5:4	SBUDPDM_REC_TIME	00	RW	DPDM OVP recovery time 00 : 400 μ s (default) 01 : 600 μ s 10 : 800 μ s 11 : 1000 μ s Note : \pm 8 μ s
			3	SBUDPDM_REC_TYPE	0	RW	SBU OVP recovery type select 0 : Recovery time compute after OV rising(default) 1 : Recovery time compute after OV falling
			2	VCONN_OV_OFF	0	RW	Switch off when VCONN OV 0 : Turn off VCONN (default) 1 : Turn off SBU1/SBU2/DP/DM/VCONN
			1	DPDM_OV_OFF	0	RW	Switch off when DPDM OV 0 : Turn off DP/DM (default) 1 : Turn off SBU1/SBU2/DP/DM/VCONN
			0	SBU_OV_OFF	0	RW	Switch off when SBU OV 0 : Turn off SBU1/SBU2 (default) 1 : Turn off SBU1/SBU2/DP/DM/VCONN

Address	Length	Register Name	Bit	Bit Name	Default	Type	Description
0x3D	1	SBUDPDM_OV_STS	7	SBU2_OV_FLAG	0	R	SBU2 OVP status 0 : No OVP occurred (default) 1 : OVP occurred
			6	SBU1_OV_FLAG	0	R	SBU1 OVP status 0 : No OVP occurred (default) 1 : OVP occurred
			5	DM_OV_FLAG	0	R	DM OVP status 0 : No OVP occurred (default) 1 : OVP occurred
			4	DP_OV_FLAG	0	R	DP OVP status 0 : No OVP occurred (default) 1 : OVP occurred
			3	STS_SBU2_SWEN	0	R	SBU2 switch status 0 : Switch off (default) 1 : Switch on
			2	STS_SBU1_SWEN	0	R	SBU1 switch status 0 : Switch off (default) 1 : Switch on
			1	STS_DM_SWEN	0	R	DM switch status 0 : Switch off (default) 1 : Switch on
			0	STS_DP_SWEN	0	R	DP switch status 0 : Switch off (default) 1 : Switch on
0x3F	1	SBU_CTRL_04	7:6	SBU_OV_SEL	10	RW	SBU1/SBU2 OVP level select 00 : 3.6V 01 : 3.7V 10 : 3.8V (default) 11 : 4.5V
			5:1	Reserved	00000	R	Reserved
			0	Reserved	1	RW	Reserved
0x53	1	FOD_CTRL_01	7:4	CTD_TIMER	0000	RW	Cable Type Detection delay time to check VBUS_VALID for TYPEC_ST. Range from 70ms to 100ms. 70ms to meet max FOD processing time and 100ms to meet min VBUS ON time. 0000 : 70ms (default) 0001 : 72ms ... 1110 : 98ms 1111 : 100ms
			3:0	FOD_TIMER	1010	RW	FOD delay time for Source role. Setting requires to meet constraints : $TFOD * 0.9 > TCTD * 1.1$ FOD delay time equal to $(CTD_TIMER + FOD_TIMER * 2)$ ms

Address	Length	Register Name	Bit	Bit Name	Default	Type	Description
0x54	1	FOD_CTRL_02	7	FODADC_SNK_EN	0	RW	Enable FOD with ADC trigger control by CC attached as SNK when FOD_SNK_EN = 0. 0 : Disable FOD with ADC HW trigger by CC attached as SNK. (default) 1 : Once cable connected (RPCONNECT_SNK = 1), FOD with ADC operation will be triggered.
			6:4	FODADC_T2	011	RW	FOD with ADC flow to do VBUS ADC measurement after FOD_ON pull-up for T2 time. 000 : 45ms 001 : 50ms 010 : 55ms 011 : 60ms (default) ... 110 : 75ms 111 : 80ms
			3	TM_FOD_DISC_EN	0	RW	Manual enable FOD_DISC_EN when FOD_TM_EN = 1. 0 : Disable FOD_DISC_EN when FOD_TM_EN = 1 (default) 1 : Enable FOD_DISC_EN when FOD_TM_EN = 1
			2:0	FODADC_T1	101	RW	FOD with ADC flow to do VBUS ADC measurement after FOD_ON pull-up for T1 time. 000 : 5ms 001 : 10ms ... 101 : 30ms ... 110 : 35ms 111 : 40ms
0x55	1	FOD_CTRL_03	7:0	FODADC_VTH0_LB	01110000	RW	FOD discharge threshold before pull up to check if initial voltage is around VBUS_SAFE0V. Default is 0.448V. Threshold voltage = {FOD_VTH0_HB, FOD_VTH0_LB} * 4mV.

Address	Length	Register Name	Bit	Bit Name	Default	Type	Description
0x56	1	FOD_CTRL_04	7:6	FODADC_ISEL	10	RW	FOD with ADC flow to select pull-up current source. 00 : 5mA 01 : 10mA 10 : 20mA (default) 11 : 20mA
			5:4	FODADC_ABN_TH	00	RW	FOD with ADC flow to select tolerance when compare FOD_VBUS_T2 and FOD_VBUS_T1 due to ADC measure deviation. If FOD_VBUS_T2 + FODADC_ABN_TH ≥ FOD_VBUS_T1, FOD_VBUS_T2 voltage is considered to be greater or equal than FOD_VBUS_T1. 00 : 2 (default) 01 : 4 10 : 6 11 : 8
			3:2	Reserved	00	R	Reserved
			1:0	FODADC_VTH0_HB	00	RW	High bit of FOD_VTH0.
0x57	1	FOD_CTRL_05	7:0	FODADC_VTH1_LB	01110000	RW	FOD pull-up threshold after T2 to check if LR when VBUS capacitance is over 1000μF. Default is 0.448V. Threshold voltage = {FOD_VTH1_HB, FOD_VTH1_LB} * 4mV.
0x58	1	FOD_CTRL_06	7:2	Reserved	000000	R	Reserved
			1:0	FODADC_VTH1_HB	00	RW	High bit of FOD_VTH1.
0x59	1	FOD_CTRL_05	7:0	FODADC_VTH2_LB	00011011	RW	FOD pull-up threshold after T2 to check if LR when VBUS capacitance is over 1000μF. Default is 0.108V. Threshold voltage = {FOD_VTH2_HB, FOD_VTH2_LB} * 4mV.
0x5A	1	FOD_CTRL_06	7:2	Reserved	000000	R	Reserved
			1:0	FODADC_VTH2_HB	00	RW	High bit of FOD_VTH1.

Address	Length	Register Name	Bit	Bit Name	Default	Type	Description
0x60	1	BC12_SNK_FUNC	7	BC12_SNK_EN	0	RW	Enable BC12 Sink side function 0 : Disable (default) 1 : Enable
			6	SPEC_TA_EN	1	RW	Enable apple TA detection 0 : Disable 1 : Enable (default)
			5:4	DCDT_SEL	10	RW	DCD timeout function select 00 : Disable DCD timeout function 01 : Enable 300ms DCD timeout function 10 : Enable 600ms DCD timeout function (default) 11 : Wait data contact
			3	VLGC_OPT	0	RW	Enable primary detection high reference voltage option 0 : Disable (default) 1 : Enable
			2	VPORT_SEL	1	RW	Voltage select for primary detection, secondary detection and HVDCP detection 0 : 0.6V 1 : Depends on DPDM_VSRC_SEL (default)
			1	BC12_WAIT_VBUS	0	RW	BC12 Sink function wait and check VBUS 0 : Not wait VBUS > 3.8V(default) 1 : Wait and check VBUS When this bit set to 1'b1, BC12 Sink function will be enabled when VBUS > 3.8V. And BC12 Sink function will be disabled when VBUS < 3.6V.
			0	Reserved	0	R	Reserved
			0x61	1	BC12_STAT	7:6	Reserved
5	HVDCP	0				R	0 : TA is not HVDCP (default) 1 : TA is HVDCP
4	DCDT	0				R	0b : DCD without time out (default) 1b : DCD time out
3:0	PORT_STAT	0000				R	0000 : No information (default) 1000 : VBUS = device 1 (2.7V & 2V mode) 1001 : VBUS = device 2 (1.2V & 1.2V mode) 1010 : VBUS = device 3 (2V & 2.7V mode) 1011 : VBUS = device 4 (2.7V & 2.7V mode) 1100 : VBUS = device 5 (2V & 2V mode)/unknown TA (500mA) 1101 : VBUS = SDP (500mA) 1110 : VBUS = CDP (1500mA) 1111 : VBUS = DCP (2400mA)

Address	Length	Register Name	Bit	Bit Name	Default	Type	Description
0x63	1	DPDM_CTR1 DPDM_SET	7	MANUAL_MODE	0	RW	Enable DPDM control by SW manual mode
			6	DPDM_DET_EN	0	RW	Enable DPDM_DET BASE
			5	DPDM_SW_VCP_EN	0	RW	Enable DPDM HVSW and charge-pump, pull gate voltage to VCP
			4	DPDM_SW_EN	0	RW	When DPDM_SW_VCP_EN = 0, Enable DPDM HVSW, pull gate voltage to VDDA (Reg direct out)
			3	DPDM_SHORT_EN	0	RW	DPDM short enable 0 : Not short (default) 1 : Short
			2	Reserved	0	R	Reserved
			1:0	DPDM_VSRC_SEL	10	RW	VDP_SRC/VDM_SRC voltage selection 00 : 0.55V 01 : 0.60V 10 : 0.65V (default) 11 : 0.70V
0x64	1	DPDM_CTR2 LDO_VSET	7	DP_LDO_EN	0	RW	While manual mode = '1', change to manual mode 0 : Disable (default) 1 : Enable
			6:4	DP_LDO_VSEL	000	RW	DP LDO output voltage selection 000 : 0.6V (DPDM_VSRC_SEL MUST = 00b) (default) 001 : 1.8V (DPDM_VSRC_SEL MUST = 01b) 010 : 2.8V (DPDM_VSRC_SEL MUST = 01b) 011 : 3.3V (DPDM_VSRC_SEL MUST = 01b) 100 : 1.2V 101 : 2.7V The other settings are reserved.
			3	DM_LDO_EN	0	RW	While manual mode = '1', change to manual mode 0 : Disable (default) 1 : Enable
			2:0	DM_LDO_VSEL	000	RW	DM LDO output voltage selection 000 : 0.6V (DPDM_VSRC_SEL MUST = 00b) (default) 001 : 1.8V (DPDM_VSRC_SEL MUST = 01b) 010 : 2.8V (DPDM_VSRC_SEL MUST = 01b) 011 : 3.3V (DPDM_VSRC_SEL MUST = 01b) 100 : 1.2V 101 : 2.7V The other settings are reserved.

Address	Length	Register Name	Bit	Bit Name	Default	Type	Description
0x65	1	DPDM_CTR3 DISCHG_SET	7	DP_DISCHG_EN	0	RW	While manual mode = '1', change to manual mode 0 : Disable (default) 1 : Enable
			6:4	DP_DISCHG_RSEL	000	RW	DP discharge resistor selection 000 : 6.0kΩ (default) 001 : 20kΩ 010 : 0.7μA 011 : 100μA 1xx : 900kΩ
			3	DM_DISCHG_EN	0	RW	While manual mode = '1', change to manual mode 0 : Disable (default) 1 : Enable
			2:0	DM_DISCHG_RSEL	000	RW	DM discharge resistor selection 000 : 6.0kΩ (default) 001 : 20kΩ 010 : 0.7μA 011 : 100μA 1xx : 900kΩ
0x66	1	DPDM_CTR4 DP_PULL_SET	7	DP_PULL_REN	0	RW	While manual mode = '1', change to manual mode 0 : Disable (default) 1 : Enable
			6:4	DP_PULL_RSEL	011	RW	DP pull-up resistor selection 000 : 1.2kΩ 001 : 10kΩ 010 : 15kΩ 011 : Bypass (~120Ω) (default) 100 : 30kΩ 101 : 102kΩ The other settings are reserved.
			3	Reserved	0	R	Reserved
			2	DP_PULL_IEN	0	RW	While manual mode = '1', change to manual mode 0 : Disable (default) 1 : Enable
			1:0	DP_PULL_ISEL	01	RW	DP pull-up current selection 01 : 10μA (default) Others : Reserved

Address	Length	Register Name	Bit	Bit Name	Default	Type	Description
0x67	1	DPDM_CTR5 DM_PULL_SET	7	DM_PULL_REN	0	RW	While manual mode = '1', change to manual mode 0 : Disable (default) 1 : Enable
			6:4	DM_PULL_RSEL	011	RW	DM pull-up resistor selection 000 : 1.2kΩ 001 : 10kΩ 010 : 15kΩ 011 : Bypass(~120Ω) (default) 100 : 30kΩ 101 : 102kΩ The other settings are reserved.
			3	Reserved	0	R	Reserved
			2	DM_PULL_IEN	0	RW	While manual mode = '1', change to manual mode 0 : Disable (default) 1 : Enable
			1:0	DM_PULL_ISEL	01	RW	DM pull-up current selection 01 : 10μA (default) Others : Reserved
0x68	1	DPDM_CTR6 DPDM_VREF_HIDET	7:5	Reserved	000	R	Reserved
			4:0	VREF_HIDET	00000	RW	DPDM voltage detection setting (HI/LO) Threshold : 0.1V to 2.6V (LSB = 0.1V) 00000 : 0.1V (default) ... 11001 : 2.6V ----- 11010 : 0.275V (BC1.2 VDAT_REF_MIN) 11011 : 0.375V (BC1.2 VDAT_REF_MAX) 11100 : 0.9V (BC1.2 VLGC_MIN) 11101 : 1.975V (BC1.2 VLGC_MAX) 11110 : 1.5V (A_DET_LO) 11111 : 2.3V (A_DET_HI)
0x69	1	DPDM_CTR7 DPDM_VREF_LODET	7:5	Reserved	000	R	Reserved
			4:0	VREF_LODET	00000	RW	DPDM voltage detection setting (HI/LO) Threshold : 0.1V to 2.6V (LSB = 0.1V) 00000 : 0.1V (default) ... 11001 : 2.6V ----- 11010 : 0.275V (BC1.2 VDAT_REF_MIN) 11011 : 0.375V (BC1.2 VDAT_REF_MAX) 11100 : 0.9V (BC1.2 VLGC_MIN) 11101 : 1.975V (BC1.2 VLGC_MAX) 11110 : 1.5V (A_DET_LO) 11111 : 2.3V (A_DET_HI)

Address	Length	Register Name	Bit	Bit Name	Default	Type	Description
0x6D	1	BC12_SRC_FUNC	7	BC12_SRC_EN	0	RW	BC12 TA function enable 0 : Disable (default) 1 : Enable
			6:4	SRC_MODE_SEL	000	RW	Mode select 000 : BC12 SDP (default) 001 : BC12 CDP 010 : BC12 DCP 011 to 111 : Reserved
			3	Reserved	0	R	Reserved
			2:1	Reserved	00	RW	Reserved
			0	WAIT_VBUS_ON	1	RW	Wait VBUS > 4.0V (VBUS_PRESENT_FLAG = 1) to enable BC12 TA function 0 : Not wait VBUS > 4.0V. BC12 TA function will enable when BC12_SRC_EN = 1b 1 : Wait VBUS > 4.0V. BC12 TA function will enable when BC12_SRC_EN = 1b and VBUS_PRESENT_FLAG = 1 (default)
0x6E	1	SRC_STS_01	7:2	Reserved	000000	R	Reserved
			1	STS_CDP_ERR	0	R	CDP flow error 0 : No CDP flow error (default) 1 : CDP flow error Note : This bit is updated after INT_BC12_TA_CHG have been set to 1b. It will keep until next time INT_BC12_TA_CHG has set to 1b. Check this bit only after INT_BC12_TA_CHG have been set to 1b.
			0	STS_CDP_DONE	0	R	CDP flow done 0 : No CDP flow (default) 1 : CDP flow done Note : This bit is updated after INT_BC12_TA_CHG have been set to 1b. It will keep until next time INT_BC12_TA_CHG has set to 1b. Check this bit only after INT_BC12_TA_CHG have been set to 1b.

Address	Length	Register Name	Bit	Bit Name	Default	Type	Description
0x70	1	SRC_CTRL_01	7:6	DPDM_GLITCH	00	RW	DP/DM deglitch 00 : 100µs (default) 01 : 132µs 10 : 168µs 11 : 200µs
			5:4	USBDET_TIMEOUT_SEL	10	RW	USB device detect timeout 00 : 1.024s 01 : 2.048s 10 : 4.096s (default) 11 : 8.192s
			3:2	PRIMARY_TIMEOUT_SEL	00	RW	Primary detection timeout 00 : 1.0s (default) 01 : 1.3s 10 : 1.6s 11 : 2.0s
			1:0	CDP_VSRC_ON_SEL	10	RW	Vsrc_on time detect 00 : 16ms 01 : 24ms 10 : 32ms (default) 11 : 40ms
0x71	1	SRC_CTRL_02	7	Reserved	0	R	Reserved
			6:5	Reserved	0	RW	Reserved
			4:0	DPDM_VOL_H2	10011	RW	DPDM voltage detection setting (HI/LO) Threshold : 0.1V to 2.6V (LSB = 0.1V) 00000 : 0.1V ... 10011 : 2.0V (default) ... 11001 : 2.6V ----- 11010 : 0.275V (BC1.2 VDAT_REF_MIN) 11011 : 0.375V (BC1.2 VDAT_REF_MAX) 11100 : 0.9V (BC1.2 VLGC_MIN) 11101 : 1.975V (BC1.2 VLGC_MAX) 11110 : 1.5V (A_DET_LO) 11111 : 2.3V (A_DET_HI) Note : In CDP mode, this register is used to check USB attach level. In private protocol mode/Auto TA mode, this register is used to check DPDM high level after device attach.

Address	Length	Register Name	Bit	Bit Name	Default	Type	Description
0x72	1	SRC_CTRL_03	7:6	Reserved	01	RW	Reserved
			5	Reserved	0	R	Reserved
			4:0	DPDM_VOL_H	01001	RW	DPDM voltage detection setting (HI/LO) Threshold : 0.1V to 2.6V (LSB = 0.1V) 00000 : 0.1V ... 01001 : 1.0V(default) ... 11001 : 2.6V ----- 11010 : 0.275V (BC1.2 VDAT_REF_MIN) 11011 : 0.375V (BC1.2 VDAT_REF_MAX) 11100 : 0.9V (BC1.2 VLGC_MIN) 11101 : 1.975V (BC1.2 VLGC_MAX) 11110 : 1.5V (A_DET_LO) 11111 : 2.3V (A_DET_HI) Note : This register is used for CDP/ private protocol to check Vdp_src high level.
0x73	1	SRC_CTRL_04	7:6	Reserved	01	RW	Reserved
			5	Reserved	0	R	Reserved
			4:0	DPDM_VOL_L	11010	RW	DPDM voltage detection setting (HI/LO) Threshold : 0.1V to 2.6V (LSB = 0.1V) 00000 : 0.1V ... 11001 : 2.6V ----- 11010 : 0.275V (BC1.2 VDAT_REF_MIN) (default) 11011 : 0.375V (BC1.2 VDAT_REF_MAX) 11100 : 0.9V (BC1.2 VLGC_MIN) 11101 : 1.975V (BC1.2 VLGC_MAX) 11110 : 1.5V (A_DET_LO) 11111 : 2.3V (A_DET_HI) Note : This register is used for CDP/ private protocol to check Vdp_src high level.

Address	Length	Register Name	Bit	Bit Name	Default	Type	Description
0xA0	1	ADC_CTRL_01	7	ADC_CH07_EN	0	RW	ADC CH07 : SBU2, 4mV/LSB 0 : Disable ADC CH07 (default) 1 : Enable ADC CH07
			6	ADC_CH06_EN	0	RW	ADC CH06 : SBU1, 4mV/LSB 0 : Disable ADC CH06 (default) 1 : Enable ADC CH06
			5	ADC_CH05_EN	0	RW	ADC CH05 : CC2, 4mV/LSB 0 : Disable ADC CH05 (default) 1 : Enable ADC CH05
			4	ADC_CH04_EN	0	RW	ADC CH04 : CC1, 4mV/LSB 0 : Disable ADC CH04 (default) 1 : Enable ADC CH04
			3	ADC_CH03_EN	0	RW	ADC CH03 : VBUS current, 33mA/LSB 0 : Disable ADC CH03 (default) 1 : Enable ADC CH03
			2	ADC_CH02_EN	0	RW	ADC CH02 : VDC, 4mV/LSB 0 : Disable ADC CH02 (default) 1 : Enable ADC CH02
			1	ADC_CH01_EN	0	RW	ADC CH01 : VBUS2, 4mV/LSB 0 : Disable ADC CH01 (default) 1 : Enable ADC CH01
			0	ADC_CH00_EN	0	RW	ADC CH00 : VBUS1, 12.5mV/LSB 0 : Disable ADC CH00 (default) 1 : Enable ADC CH00
0xA1	1	ADC_CTRL_02	7:2	Reserved	000000	R	Reserved
			1	ADC_CH09_EN	0	RW	ADC CH09 : DM, 4mV/LSB 0 : Disable ADC CH09 (default) 1 : Enable ADC CH09
			0	ADC_CH08_EN	0	RW	ADC CH08 : DP, 4mV/LSB 0 : Disable ADC CH08C(default) 1 : Enable ADC CH08
0xA2	1	ADC_CTRL_03	7:4	PRIORITY_CH_SEL	1111	RW	Select priority channel 0000 : CH00 0001 : CH01 1011 : CH11 Other : No priority 1111 : No priority (default)
			3:0	ADC_INT_SEL	0000	RW	Select INT_ADC report channel 0000 : CH00 (default) 0001 : CH01 1011 : CH11 1100 : Reserved 1101 : Reserved 1110 : Reserved 1111 : Report all channel

Address	Length	Register Name	Bit	Bit Name	Default	Type	Description
0xA3	1	ADC_CTRL_04	7:6	EN_TIME	01	RW	ADC enable wait time 00 : 7.33μs 01 : 40μs (default) 10 : 80μs 11 : 160μs
			5	reserved	0	R	Reserved
			4	ADC_CLAMP_EN	1	RW	ADC Clamp enable 0 : Disable clamp (get original ADC output) 1 : Enable clamp (get clamp ADC output) (default)
			3:2	WAIT_TIME	01	RW	ADC channel switch wait time 00 : 7.92μs 01 : 10.66μs(default) 10 : 13.33μs 11 : 16μs
			1:0	AVG_SEL	11	RW	ADC average count select 00 : 1 01 : 2 10 : 4 11 : 8 (default)
0xA4	1	ADC_CTRL_05	7:3	Reserved	00000	R	Reserved
			2	OFF_VRPBUF	0	RW	Select the reference input 0 : aVRP_bfr (default) 1 : aVRP
			1:0	SEL_WIDTH	00	RW	Sample period duration 00 : Sample time is 2T. (default) 01 : Sample time is 4T. 10 : Sample time is 6T. 11 : Sample time is 8T. Where T is a period of clock.

Address	Length	Register Name	Bit	Bit Name	Default	Type	Description
0xA5	1	ADC_CTRL_06	7	Reserved	0	R	Reserved
			6:4	SX_CMP	011	RW	Tuning comparator current 000 : 120 μ A 001 : 160 μ A 010 : 200 μ A 011 : 240 μ A (default) 100 : 280 μ A 101 : 320 μ A 110 : 360 μ A 111 : 400 μ A
			3:2	SX_BUF	01	RW	Tuning input unity-gain buffer bias current 00 : 2.5 μ A 01 : 5 μ A (default) 10 : 7.5 μ A 11 : 10 μ A
			1:0	SX_VREF	00	RW	Tuning aVRP_bfr buffer bias current 00 : 2.5 μ A (default) 01 : 5 μ A 10 : 7.5 μ A 11 : 10 μ A
0xA6	1	ADC_CH00_VOL_L	7:0	ADC_CH00_VOL_L	00000000	R	ADC CH00 (VBUS1) report low byte, 12.5mV/LSB
0xA7	1	ADC_CH00_VOL_H	7:4	Reserved	0000	R	Reserved
			3:0	ADC_CH00_VOL_H	0000	R	ADC CH00 (VBUS1) report high byte, 12.5mV/LSB
0xA8	1	ADC_CH01_VOL_L	7:0	ADC_CH01_VOL_L	00000000	R	ADC CH01 (VBUS2) report low byte, 4mV/LSB
0xA9	1	ADC_CH01_VOL_H	7:4	Reserved	0000	R	Reserved
			3:0	ADC_CH01_VOL_H	0000	R	ADC CH01 (VBUS2) report high byte, 4mV/LSB
0xAA	1	ADC_CH02_VOL_L	7:0	ADC_CH02_VOL_L	00000000	R	ADC CH02 (VDC) report low byte, 4mV/LSB
0xAB	1	ADC_CH02_VOL_H	7:4	Reserved	0000	R	Reserved
			3:0	ADC_CH02_VOL_H	0000	R	ADC CH02 (VDC) report high byte, 4mV/LSB
0xAC	1	ADC_CH03_VOL_L	7:0	ADC_CH03_VOL_L	00000000	R	ADC CH03 (VBUS current) report low byte, 33mA/LSB
0xAD	1	ADC_CH03_VOL_H	7:4	Reserved	0000	R	Reserved
			3:0	ADC_CH03_VOL_H	0000	R	ADC CH03 (VBUS current) report low byte, 33mA/LSB
0xAE	1	ADC_CH04_VOL_L	7:0	ADC_CH04_VOL_L	00000000	R	ADC CH04 (CC1) report low byte, 4mV/LSB

Address	Length	Register Name	Bit	Bit Name	Default	Type	Description
0xAF	1	ADC_CH04_VOL	7:4	Reserved	0000	R	Reserved
			3:0	ADC_CH04_VOL_H	0000	R	ADC CH04 (CC1) report high byte, 4mV/LSB
0xB0	1	ADC_CH05_VOL_L	7:0	ADC_CH05_VOL_L	00000000	R	ADC CH05 (CC2) report low byte, 4mV/LSB
0xB1	1	ADC_CH05_VOL	7:4	Reserved	0000	R	Reserved
			3:0	ADC_CH05_VOL_H	0000	R	ADC CH05 (CC2) report high byte, 4mV/LSB
0xB2	1	ADC_CH06_VOL_L	7:0	ADC_CH06_VOL_L	00000000	R	ADC CH06 (SBU1) report low byte, 4mV/LSB
0xB3	1	ADC_CH06_VOL	7:4	Reserved	0000	R	Reserved
			3:0	ADC_CH06_VOL_H	0000	R	ADC CH06 (SBU1) report high byte, 4mV/LSB
0xB4	1	ADC_CH07_VOL_L	7:0	ADC_CH07_VOL_L	00000000	R	ADC CH07 (SBU2) report low byte, 4mV/LSB
0xB5	1	ADC_CH07_VOL	7:4	Reserved	0000	R	Reserved
			3:0	ADC_CH07_VOL_H	0000	R	ADC CH07 (SBU2) report high byte, 4mV/LSB
0xB6	1	ADC_CH08_VOL_L	7:0	ADC_CH08_VOL_L	00000000	R	ADC CH08 (DP) report low byte, 4mV/LSB
0xB7	1	ADC_CH08_VOL	7:4	Reserved	0000	R	Reserved
			3:0	ADC_CH08_VOL_H	0000	R	ADC CH08 (DP) report high byte, 4mV/LSB
0xB8	1	ADC_CH09_VOL_L	7:0	ADC_CH09_VOL_L	00000000	R	ADC CH09 (DM) report low byte, 4mV/LSB
0xB9	1	ADC_CH09_VOL	7:4	Reserved	0000	R	Reserved
			3:0	ADC_CH09_VOL_H	0000	R	ADC CH09 (DM) report high byte, 4mV/LSB

Address	Length	Register Name	Bit	Bit Name	Default	Type	Description
0xC0	1	IO_CTRL	7	I2C_MODE	1	RW	I ² C max speed 0 : Up to 400kHz 1 : Up to 3.4MHz (default)
			6	Reserved	0	R	Reserved
			5:4	GPIO3_DRV	00	RW	GPIO3 output driving capability ability 00 : 20mV/s (default) 01 : 40mV/s 10 : 60mV/s 11 : 80mV/s
			3:2	GPIO2_DRV	00	RW	GPIO2 output driving capability ability 00 : 20mV/s (default) 01 : 40mV/s 10 : 60mV/s 11 : 80mV/s
			1:0	GPIO1_DRV	00	RW	GPIO1 output driving capability ability 00 : 20mV/s (default) 01 : 40mV/s 10 : 60mV/s 11 : 80mV/s
0xC1	1	SRCDET_CTRL	7:6	Reserved	00	R	Reserved
			5:4	SRCDET_SETTING	00	R	SRCDET Setting 00 : No SRCDET function (default) 01 : Check CC for 1.5A 10 : Check CC for 3.0A 11 : Reserved
			3:2	Reserved	00	R	Reserved
			1	GPIO3_SOFT_RSTN_EN	1	RW	GPIO3_SOFT_RSTN_EN, Reset REG 0xEF[3:1] (GPIO3_OD_N, GPIO3_OE, GPIO3_O), RT2_REG 0xC0[5:4] GPIO3_DRV, when soft reset trigger 0 : Disable 1 : Enable (default)
			0	SRCDET_CTRL_EN	1	RW	SRCDET_CTRL_EN, Turn on VBUS (GPIO3) when special RP level attach, depend on SRCDET PIN 0 : Disable 1 : Enable (default)

Application Information

USB_PD

The PD function of the RT1718S complies with USB Power Delivery spec 3.0 and Type-C Port Controller Interface spec 1.0. Some "Not support" functions are listed in the register table.

Type-C Detection

The USB_PD implements multiple comparators which can be used by software to determine the state of the CC1, CC2 pins. This status information provides the host processor all of the information required to determine attach and detach status of the cable. The USB_PD has three threshold comparators, which match the USB Type-C specification for the three charge current levels, which can be detected by a Type-C device. These comparators can automatically trigger interrupts when there is a state change.

Type-C Role

The RT1718S supports to be as DRP (dual role port), SRC (source) only, or SNK (sink) only port. In DRP, the CC pins of RT1718S will toggle between Rp and Rd periodically.

Dead Battery Mode

The RT1718S supports Dead battery Rd by adding 200Ω resistors between CC1 (pin5) and RPD_CC1 (pin 3) as well as CC2 (pin 7) and RPD_CC2 (pin 4). The CC pins of RT1718S will present Dead Battery Rd and it is for a Source to recognize the Sink and provide VBUS. The dead battery system or UFP powered system with RT1718S inside can be powered on from VBUS. The CC pins of RT1718S will present real Rd (5.1kΩ) when the RT1718S exits shipping mode (0x8F[5] = 1b). Therefore, the RT1718S cannot recognize the source ability until the RT1718S exit shipping mode.

Abbreviations

Term	Description
BMC	Biphase Mark Coding
TCPC	Type-C Port Controller
TCPCI	Type-C Port Controller Interface
TCPM	Type-C Port Manager

Type-C Port Controller (TCPC) Interface

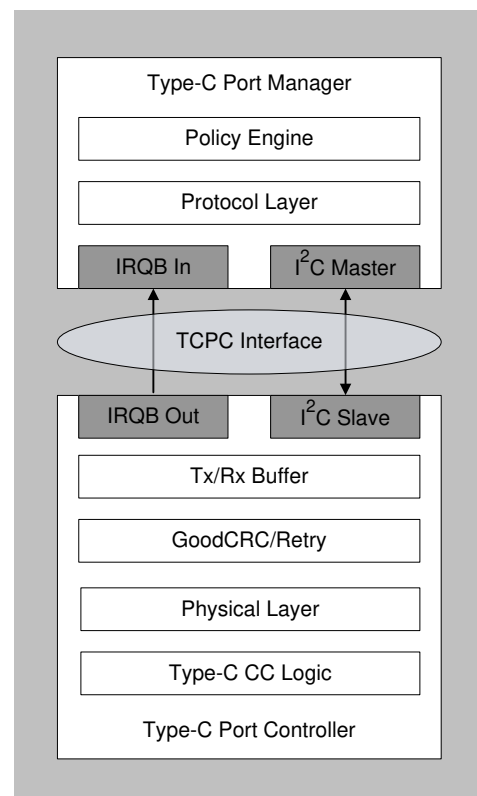

The Type-C Port Controller Interface, TCPCI, is the interface between a Type-C Port Manager and a Type-C Port Controller.

The Controller Interface uses the I²C Protocol

- The TCPM is the only master on this I²C bus
- The TCPC is a slave device on this I²C bus
- Each Type-C port has its own unique I²C slave address. The TCPC shall have equal numbers of unique I²C slave addresses and supported Type-C ports

- The TCPC supports Fast-mode bus speed
- The TCPC has an open drain output, active low IRQB pin. This pin is used to indicate change of state, where IRQB pin is asserted when any Alert Bits are set
- The TCPCI supports an I/O nominal voltage range of 1.8V and 3.3V
- The TCPC can auto-increment the I²C internal register address of the last byte transferred during a read independent of an ACK/NACK from the master

I²C Interface

• Slave Address

The RT1718S can be configured to four slave addresses by setting the resistance between ADDR (pin 15) and GND.

I ² C Address in 7bit	Resistance between ADDR and GND (Unit : kΩ)
0x40	0
0x41	309
0x42	649
0x43	open

Taking the 0x43 in 7bit for example.

RT1718S I ² C Slave Address			
MSB	LSB	R/W bit	R/W
100001	1	1/0	87/86

The I²C interface bus must be connect a resistor 1kΩ to power node and independent connection to processor, individually.

The I²C timing diagrams are listed below.

• Read and Write Function

Read single byte of data from Register

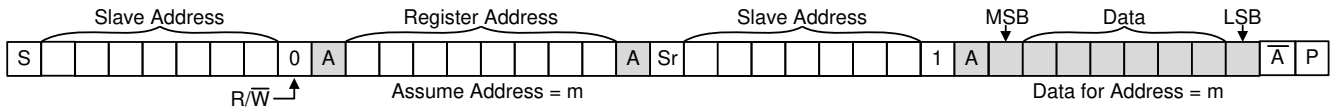

Read N bytes of data from Registers

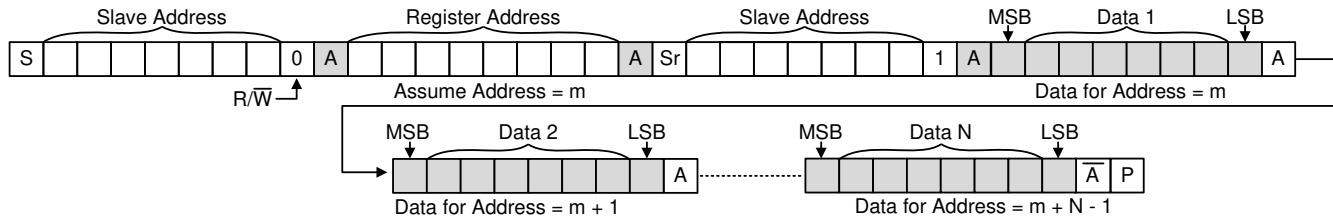

Write single byte of data to Register

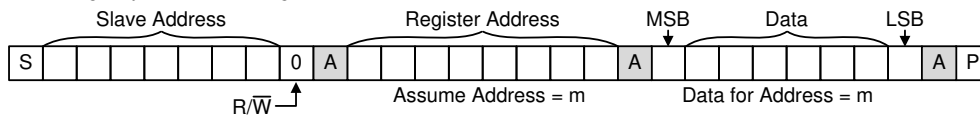

Write N bytes of data to Registers

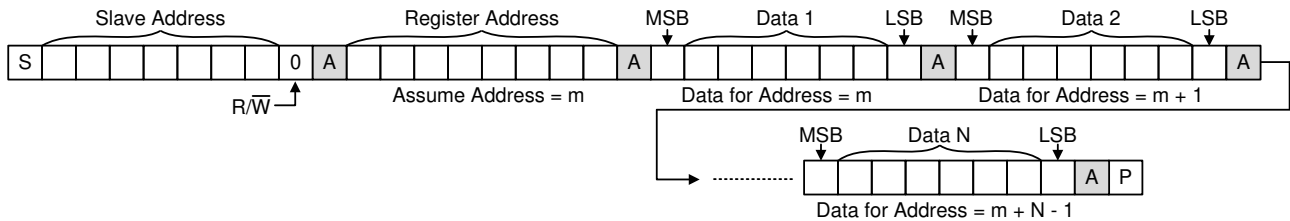

□ Driven by Master, ■ Driven by Slave, □ P Stop, □ S Start, □ Sr Repeat Start

• I²C Waveform Information

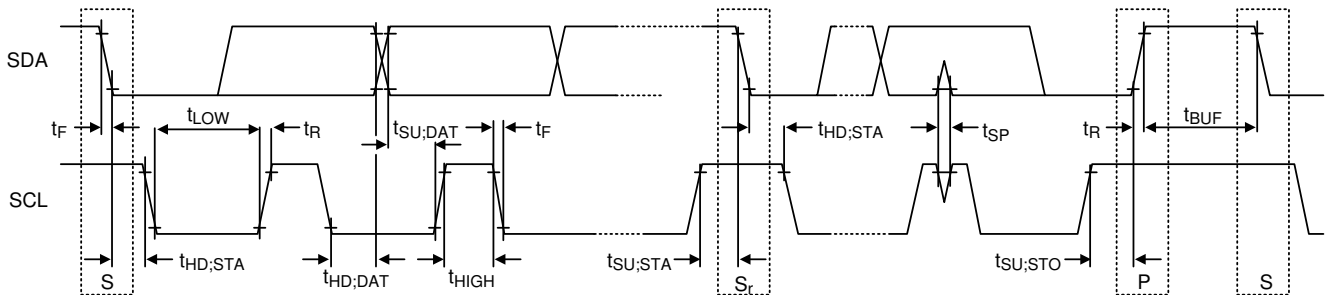

- **Operation for Page 2 of Register Map**

If the registers in page 2 are read/written, 0xF2 has to be increased between slave address and the register address of page 2. The following are the example patterns of read and write for 0xA2 in page 2 with slave address 0x43.

Example pattern to write 0xA0 = 01h in page 2.

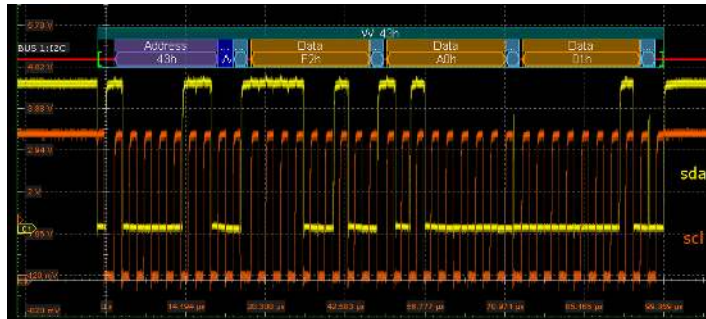

Example pattern to read 0xA0 in page 2.

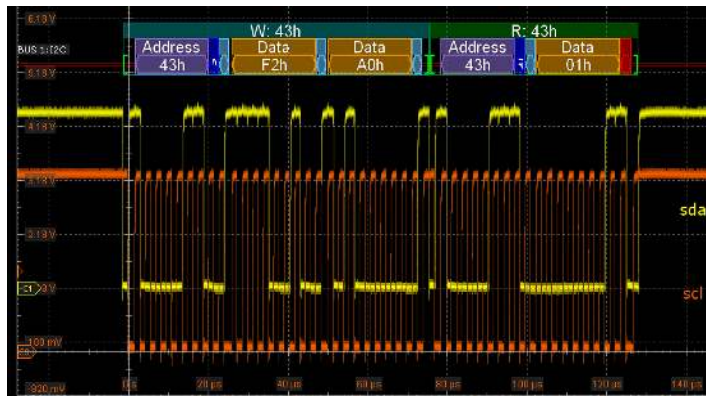

USB PD Power Mode

There are four power modes in RT1718S during operation. Shipping mode after power on, normal operation after exiting shipping mode, auto idle mode mainly for attached, and auto low power mode for non-attached. The following diagram shows the power mode transition between each mode.

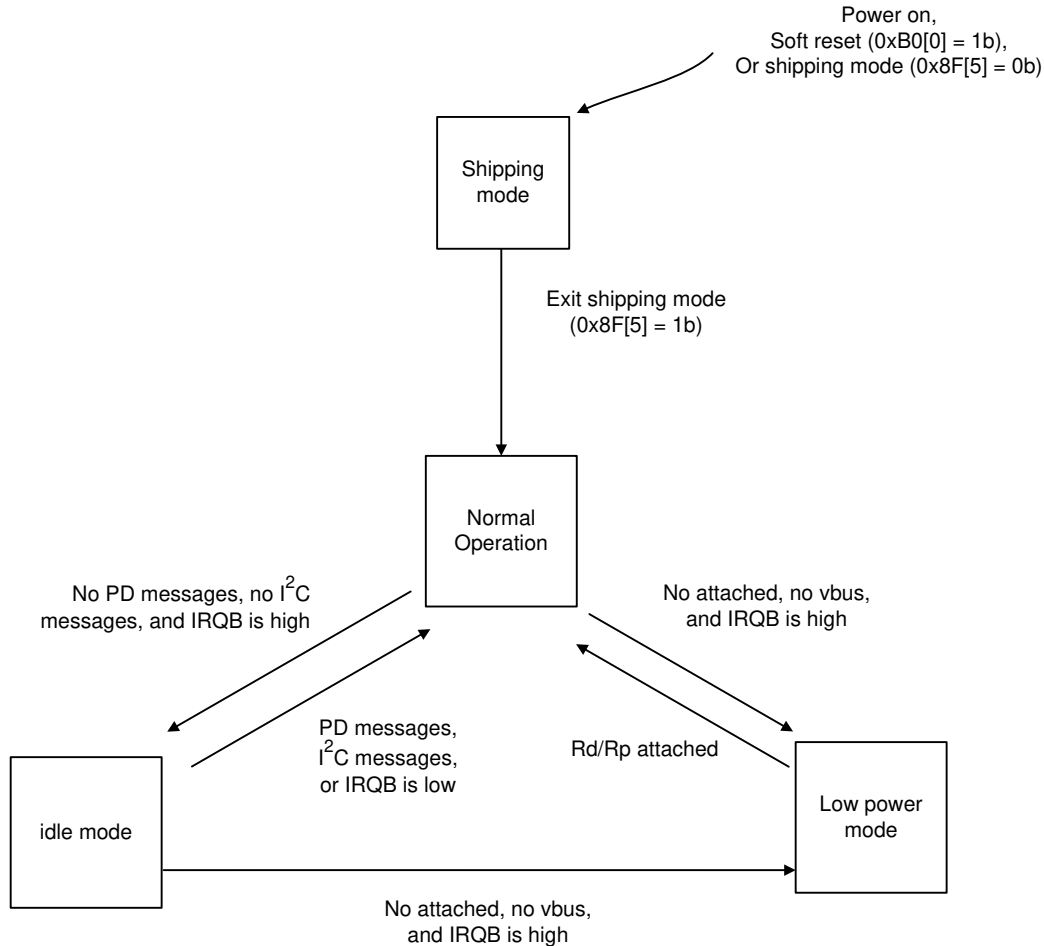

Shipping Mode

The RT1718S will be in shipping mode after power on. RT1718S will not response to the I²C commands for 3ms after VCC > 2.7V.

In shipping mode, only I²C function work.

0x8F[5] = 1b :

The RT1718S will exit from shipping mode to normal operation. Please do not send I²C commands after writing 0x8F[5] = 1b by 2ms. In this 2ms, RT1718S will not response to the I²C commands.

0x8F[5] = 0b :

Writing 0x8F[5] = 0b to return into shipping mode.

Address	Length	Bit	Bit Name	Default	Type	Description
0x8F	1	5	SHIPPING_OFF	0	RW	0 : Shipping mode 1 : Non-shipping mode

Auto Idle Mode

When auto idle function is enabled, auto idle mode timer starts to count if there is no RX or TX of PD commands, no I²C commands, and the IRQB (pin 20) is high. If there is RX or TX of PD commands, I²C commands, or the IRQB (pin 20) is low, auto idle mode timer will be reset. The RT1718S will enter idle mode automatically after auto idle timer expired. In idle mode, only the 24MHz oscillator for RX of PD commands is off. However, if there is RX of PD commands transmitted from port partner, the RT1718S can still catch the commands and inform TCPM by IRQB low due to 0x10[2] = 1b.

The RT1718S will also exit from idle mode to normal operation when there is I²C processing, PD commands or IRQB is low.

0x8F[3] = 1b :

Auto idle mode is enabled.

0x8F[3] = 0b :

Auto idle mode is disabled. The RT1718S will be in normal operation if there is no other power saving mode set.

Address	Length	Bit	Bit Name	Default	Type	Description
0x8F In Page 1	1	3	AUTOIDLE_EN	0	RW	The auto idle mode control 0 : Auto enter idle mode disable (default) 1 : Auto enter idle mode enable
	3	2:0	AUTOIDLE_TIMEOUT	000	RW	These bits can be used to set the time before entering into auto idle And the time setting is based on : (AUTOIDLE_TIMEOUT * 2 + 1) * 6.4ms 000 : 6.4ms (default) 001 : 19.2ms 010 : 32ms 111 : 96ms

Auto Low Power Mode

When auto low power function is enabled, auto low power timer starts to count if there is no attachment on CC, the vbus is not present (0x1E[2] = 0b), and the IRQB (pin 20) is high. If there is attachment on CC, the vbus is present (0x1E[2] = 0b), or the IRQB (pin 20) is low, auto low power timer will be reset. 0x90 at page1 will be updated by 0xB8 in page1 when auto low power timer is expired. The main recommended updated bits in 0x90 are 0x90[3] and 0x90[0]. There are no RX and TX functions of PD when the RT1718S is in low power mode. The RT1718S will exit from low power mode to normal operation (0x90[3] = 0b) when there is Rd or Rp attachment. RX and TX functions of PD can be active again (0x90[0] = 1b) only when there are attach events except for single Ra attached.

0xF210[5:4] is the setting for auto low power timer.

0xF210[2:0] = 000b :

Auto low power mode is disabled.

0xF210[2:0] = 101b :

Auto low power mode is enabled.

The recommended 0xB8 value is 1Ah.

0xB8[4] = 1b :

When auto low power mode timer is expired, 0x90[4] is updated by 0xB8[4] = 1b and then the bandgap reference current is on in low power mode for VBUS detection.

0xB8[3] = 1b :

When auto low power mode timer is expired, 0x90[3] is updated by 0xB8[3] = 1b and then the RT1718S enters low power mode.

0xB8[1] = 1b :

When auto low power mode timer is expired, 0x90[1] is updated by 0xB8[1] = 1b and then VBUS detection is on.

0xB8[0] = 0b :

When auto low power mode timer is expired, 0x90[0] is updated by 0xB8[0] = 0b and then 24MHz oscillator is off.

Address	Bit	Bit Name	Default	Type	Description
0xB8 at Page 1	7:0	RTINI_REG90	00000000	RW	Update to 0x90 when auto low power timer is expired with 0xF210[2:0] = 101b.
0x10 at Page 2	5:4	AUTO_LPWR_TIMEOUT	00	RW	These bits can be used to set the time before entering into auto low power. 00 : 1.0s (default) 01 : 1.5s 10 : 2.0s 11 : 2.5s
	2:0	AUTO_LPWR_EN	000	RW	For open Source TCPM to enter low power mode when unattached. Auto write low power control register per below scenario. 000 : Disable (default) 100 : HW auto update 0x90 = RTINI_REG90 when reach auto low power timeout. Auto low power timer is enabled when TCPC is in normal mode with CCx_Status are both opened and no IRQB Event and VBUS_PRESENT = 0. 101 : HW auto update 0x90 = RTINI_REG90 when reach auto low power timeout. Auto low power timer is enabled when TCPC is in normal mode with CCx_Status are both opened for Sink or CCx_Status has single RA for Source and no IRQB Event and VBUS_PRESENT = 0. 110/111 : Disable The other settings are reserved.

Soft Reset

The all registers of RT1718S can be reset to default value by writing SOFT_RESET (0xB0[0]) as 1b, except for SRCDET function. Please refer to the SRCDET section for more detail information. RT1718S will not response to the I²C commands for 2ms after writing SOFT_RESET (0xB0[0]) as 1b.

Address	Bit	Bit Name	Default	Type	Description
0xB0	0	SOFT_RESET	0	W	When writing 1b to this bit, it will trigger soft-reset event, and all register setting will reset to default value.

Fast Role Swap (Initial Sink)

As initial sink in FRS, here is the introduction to the settings.

0xCC[6] = 1b : Set FRS RX detection enabled.

0xCB[3:2] : Set the FRS RX detection threshold

When the voltage level of CC pin is lower than 0xCB[3:2] for 40 μ s, the INT_RX_FRS (0x98[6]) will be 1b. The RX_FRS (0x9F[6]) will be 1b only between FRS signal received (0x98[6] = 0b \rightarrow 1b) and the voltage level of CC higher than 0xCB[3:2] again.

0xCC[3] = 1b : Set FRS VBUS detection enabled.

0xCC[2:0] : Set the FRS VBUS detection threshold.

When the voltage level of VBUS pin is lower than 0xCC[2:0], the INT_VBUS_FRS_LOW (0x98[7]) will be 1b and the VBUS_RX_FRS_LOW (0x9F[7]) will be 0b. When the voltage level of VBUS pin is higher than 0xCC[2:0] again, the VBUS_RX_FRS_LOW (0x9F[7]) will be 1b.

0xCE[3:0] : Set the reload condition of GPIO2, GPIO1, GPB, and GPB for FRS RX events.

For controlling sink path, it is recommended to set as 0b. It means turning off sink path right after FRS signal received.

For controlling source path, it is recommended to set as 1b. It means turning on source path after FRS signal is received and VBUS is low enough.

Please refer to GPA/B or GPIO1/2 for reload values setting.

Address	Bit	Bit Name	Default	Type	Description
0xCB	3:2	VREF_RX_FRS	10	RW	Fast role-swap detection threshold on CC pin 00 : 0.48V 01 : 0.50V 10 : 0.52V (default) 11 : 0.54V
0xCC	6	RX_FRS_EN	0	RW	Fast-role swap rx detection enable 0 : Disable (default) 1 : Enable
0xCC	4	FR_VBUS_SELECT	1	RW	FR_VBUS_FLAG is de-bounced or not. 0 : Not de-bounce FR_VBUS_VALID 1 : De-bounce FR_VBUS_VALID (default)
	3	VBUS_FRS_EN	0	RW	VBUS Fast Role-Swap detection enable 0 : Disable (default) 1 : Enable
	2:0	VREF_VBUS_FRS	000	RW	VBUS Fast Role-Swap detection threshold selection 000 : 4.8V (default) 001 : 4.9V 010 : 5.0V 011 : 5.1V 100 : 5.2V 101 : 5.3V 110 : 5.4V 111 : 5.5V
0xCE	3	FRS_RX_WAIT_GPIO2	0	RW	GPIO2 reload when receive fast role swap event 0 : Reload setting when receive fast role swap event (default) 1 : Reload setting when receive fast role swap event and VBUS < VREF_VBUS_FRS
	2	FRS_RX_WAIT_GPIO1	0	RW	GPIO1 reload when receive fast role swap event 0 : Reload setting when receive fast role swap event (default) 1 : Reload setting when receive fast role swap event and VBUS < VREF_VBUS_FRS
	1	FRS_RX_WAIT_GPB	0	RW	GPB reload when receive fast role swap event 0 : Reload setting when receive fast role swap event (default) 1 : Reload setting when receive fast role swap event and VBUS < VREF_VBUS_FRS
	0	FRS_RX_WAIT_GPA	0	RW	GPA reload when receive fast role swap event 0 : Reload setting when receive fast role swap event (default) 1 : Reload setting when receive fast role swap event and VBUS < VREF_VBUS_FRS
0x91	7	M_VBUS_FRS_LOW	0	RW	0 : Interrupt masked (default) 1 : Interrupt unmasked
	6	M_RX_FRS	0	RW	0 : Interrupt masked (default) 1 : Interrupt unmasked

Address	Bit	Bit Name	Default	Type	Description
0x98	7	INT_VBUS_FRS_LOW	0	WC	0 : Cleared (default) 1 : Fast Role Swap Vbus Valid Falling (< 4.75V)
	6	INT_RX_FRS	0	WC	0 : Cleared (default) 1 : Fast-role swap rx detection alert.
0x9F	7	VBUS_FRS_LOW	0	R	VBUS FRS voltage detection 0 : VBUS < VREF_VBUS_FRS (default) 1 : VBUS > VREF_VBUS_FRS
	6	RX_FRS	0	R	Fast-role swap rx detection alert. 0 : CC > VREF_RX_FR (default) 1 : CC < VREF_RX_FR

Gate Control

• General Setting

The output voltage high level of GPA and GPB is up to VBUS + 4.5V and the low level is GND. GPA and GPB are recommended to control the paths for VBUS only. The charge pumps (0xEC[1:0]) of GPB and GPA default to being on after the RT1718S exits shipping mode. There is an option to disable the charge pump of GPB or GPA (0xEC[3:2]) when RT1718S enters low power mode. When the RT1718S enters normal operation from low power mode, the status of charge pump of GPB or GPA depends on 0xEC[1:0] and 0xDD. If 0xEC[5] = 1b or 0xEC[4] = 1b, GPB or GPA can be controlled by 0x23 and be updated due to VBUS fault events and FRS.

Address	Bit	Bit Name	Default	Type	Description
0xEC	5	GPB_VBUS_PATH_EN	1	RW	GPB setting (GPB_CTRL) auto reload with TCPC command, VBUS OV/OC/RC event, and FRS event 0 : GPB setting (GPB_CTRL) will not auto reload 1 : GPB setting (GPB_CTRL) will auto reload (default)
	4	GPA_VBUS_PATH_EN	1	RW	GPA setting (GPA_CTRL) auto reload with TCPC command, VBUS OV/OC/RC event, and FRS event 0 : GPA setting (GPA_CTRL) will not auto reload 1 : GPA setting (GPA_CTRL) will auto reload (default)
	3	VBUS_CPGPB_AUTO_OFF	1	RW	Auto disable VBUS Charge-pump for GPB when in low power mode 0 : Not auto disable 1 : Auto disable when in low power mode (default)
	2	VBUS_CPGPA_AUTO_OFF	1	RW	Auto disable VBUS Charge-pump for GPA when in low power mode 0 : Not auto disable 1 : Auto disable when in low power mode (default)
	1	VBUS_CPGPB_EN	1	RW	VBUS Charge-pump for GPB 0 : Disable 1 : Enable (default)
	0	VBUS_CPGPA_EN	1	RW	VBUS Charge-pump for GPA 0 : Disable 1 : Enable (default)

• **GPB/GPA Auto Reloaded**

GPB and GPA can be controlled directly by writing 0xDD with 0xEC[1:0] = 11b no matter what 0xEC[5:4] is. If 0xEC[5] = 1b, 0xDD[7:4] will be updated according to the relative events. If 0xEC[4] = 1b, 0xDD[3:0] will be updated according to the relative events. 0xEC[5:4] = 11b in the following tables.

Writing 0x23 with	0xDD is updated by
44h (Disable Sink Vbus)	The value of 0xDE
55h (Sink Vbus)	The value of 0xDF
66h (Disable Source Vbus)	The value of 0xE0
77h (Source Vbus Default Voltage)	The value of 0xE1
88h (Source Vbus High Voltage)	The value of 0xE2

VBUS fault	0xDD is updated by
VBUS OCP1	The value of 0xE3
VBUS OCP2	The value of 0xE4
VBUS OCP3	The value of 0xE5
VBUS OVP	The value of 0xE6
VBUS RCP1/3	The value of 0xE7

FRS	0xDD is updated by
FRS signal received	The value of 0xE9

GPIO

• **General Setting**

As output, the output voltage high level of GPIOx is up to VCCIO and the low level is GND. If 0xEC[7] = 1b or 0xEC[6] = 1b, GPIO2 or GPIO1 can be controlled by 0x23 and be updated due to FRS.

Address	Bit	Bit Name	Default	Type	Description
0xEC	7	GPIO2_VBUS_PATH_EN	0	RW	GPIO2 setting (GPIO2_OD_N/GPIO2_OE/GPIO2_O) auto reload with TCPC command and FRS event 0 : GPIO2 setting (GPIO2_OD_N/GPIO2_OE/GPIO2_O) will not auto reload (default) 1 : GPIO2 setting (GPIO2_OD_N/GPIO2_OE/GPIO2_O) will auto reload
	6	GPIO1_VBUS_PATH_EN	0	RW	GPIO1 setting (GPIO1_OD_N/GPIO1_OE/GPIO1_O) auto reload with TCPC command and FRS event 0 : GPIO1 setting (GPIO1_OD_N/GPIO1_OE/GPIO1_O) will not auto reload (default) 1 : GPIO1 setting (GPIO1_OD_N/GPIO1_OE/GPIO1_O) will auto reload

• GPIO1/GPIO2 Auto Reloaded

GPIO1 and GPIO2 can be controlled directly by writing 0xED and 0xEE matter what 0xEC[7:6] is. If 0xEC[7] = 1b, 0xEE[3:1] will be updated according to the relative events. If 0xEC[6] = 1b, 0xED[3:1] will be updated according to the relative events. 0xEC[7:6] = 11b in the following tables.

Writing 0x23 with	GPIO2 : 0xEE[3:2] = 11b 0xEE[1] is updated by	GPIO1 : 0xED[3:2] = 11b 0xED[1] is updated by
44h (Disable Sink Vbus)	0xEB[0]	0xEA[0]
55h (Sink Vbus)	0xEB[1]	0xEA[1]
66h (Disable Source Vbus)	0xEB[2]	0xEA[2]
77h (Source Vbus Default Voltage)	0xEB[3]	0xEA[3]
88h (Source Vbus High Voltage)	0xEB[4]	0xEA[4]

FRS	GPIO2 : 0xEE[3:2] = 11b 0xEE[1] is updated by	GPIO1 : 0xED[3:2] = 11b 0xED[1] is updated by
FRS signal received	0xEB[6]	0xEA[6]

VBUS OCP

There are three VBUS OCP functions in RT1718S. The sensing current is through the sensing resistor between CS pin (pin 29) and VBUS pin (pin 30). The current direction is from CS to VBUS. The resistance should be 10mΩ.

With GPA_VBUS_PATH_EN (0xEC[4]) and GPB_VBUS_PATH_EN (0xEC[5])

• VBUS OCP1

When the VBUS current through the sensing resistor is over the threshold (0x16 in page 2) and for the de-bounce time (0x19 in page 2), Vbus_OC of fault status (0x1F[3]) will be 1b and GPA as well as GPB (0xDD) will be updated by Fault_OC1_VBUS_CTRL (0xE3) with VBUS_OC enabled (0x1B[2] = 0b).

For example, if the VBUS OCP1 is designed at 3A for keeping 400ms, then 0x16 in page 2 is set as 1Ch and 0x19 in page 2 is set as 28h or 88h.

Address	Bit	Bit Name	Default	Type	Description
0x1B	2	DIS_VBUS_OC	0	RW	0 : Vbus OCP1 enabled. (default) 1 : Vbus OCP1 disabled
0x16 in Page 2	6:0	VBUS_OCP1_SEL	0100010	RW	0000000 : 0.2A 0000001 : 0.3A ... 0100010 : 3.6A (default) ... 1111111 : 12.9A
0x19 in Page 2	7	VBUS_OCP1_50MS	0	RW	0b : 10ms/step (default) 1b : 50ms/step
	6:0	VBUS_OCP1_TIME	1010000	RW	0000000 : 0 step 0000001 : 1 step ... 1010000 : 80 step (default) ... 1111111 : 127 steps
0x15	3	M_VBUS_OC	1	RW	0 : Interrupt masked 1 : Interrupt unmasked (default)
0x1F	3	VBUS_OC	0	RW	0 : Not in an OC protection state (default) 1 : Over-current fault latched

• VBUS OCP2

When the VBUS current through the sensing resistor is over the threshold (0x17 in page 2) and for the de-bounce time (0x1A in page 2), INT_Vbus_OC2 (0xA9[0]) will be 1b and GPA as well as GPB (0xDD) will be updated by Fault_OC2_VBUS_CTRL (0xE4) with VBUS_OC2 enabled (0x14[1] in page 2 as 1b).

For example, if the VBUS OCP2 is designed at 6A for keeping 50ms, then 0x17 in page 2 is set as 3Ah and 0x1A in page 2 is set as 05h or 81h.

Address	Bit	Bit Name	Default	Type	Description
0x14 in Page 2	1	VBUS_OC2_EN	0	RW	0 : Vbus OCP2 disabled (default) 1 : Vbus OCP2 enabled
0x17 in page2	6:0	VBUS_OCP2_SEL	0100010	RW	0000000 : 0.2A 0000001 : 0.3A ... 0100010 : 3.6A (default) ... 1111111 : 12.9A
0x1A in page2	7	VBUS_OCP2_50MS	0	RW	0b : 10ms/step (default) 1b : 50ms/step
	6:0	VBUS_OCP2_TIME	1010000	RW	0000000 : 0 step 0000001 : 1 step ... 1010000 : 80 step ... 1111111 : 127 steps
0xA7	0	MASK_VBUS_OC2	0	RW	0 : Interrupt masked (default) 1 : Interrupt unmasked
0xA9	0	INT_VBUS_OC2	0	RW	0 : No action (default) 1 : VBUS OCP2 occurred Note : This bit cannot be cleared until VBUS OCP2 events disappeared.

• VBUS OCP3

When the VBUS current through the sensing resistor is over the threshold (0x18 in page 2), INT_VBUS_OC3 (0xA9[1]) will be 1b and GPA as well as GPB (0xDD) will be updated by Fault_OC3_VBUS_CTRL (0xE5) with VBUS_OC3 enabled (0x14[4] in page 2 as 1b).

Address	Bit	Bit Name	Default	Type	Description
0x14 in Page 2	4	VBUS_OC3_EN	0	RW	0 : Vbus OCP3 disabled (default) 1 : Vbus OCP3 enabled
0x18 in Page 2	1:0	VBUS_OCP3_SEL	10	RW	00 : 7.25A 01 : 9A 10 : 12A (default) 11 : 15A
0xA7	1	MASK_VBUS_OC3	0	RW	0 : Interrupt masked (default) 1 : Interrupt unmasked
0xA9	1	INT_VBUS_OC3	0	RW	0 : No action (default) 1 : VBUS OCP3 occurred Note : This bit cannot be cleared until VBUS OCP3 events disappeared.

VBUS OVP

When the VBUS is higher than the threshold (0x13 in page2) for the de-bounce time (0x13[6] in page 2), Vbus_OV of fault status (0x1F[2]) will be 1b and GPA as well as GPB (0xDD) will be updated by Fault_OV_VBUS_CTRL (0xE6) with VBUS_OV enabled (0x1B[1] = 0b). For example, if the VBUS = 15V and the VBUS OVP is designed at more 20% than VBUS, then 0x13 in page 2 is set as 7Ah. No de-bounce for VBUS OVP is recommended (0x13[6] in page 2 as 1b).

Address	Bit	Bit Name	Default	Type	Description
0x1B	1	DIS_VBUS_OV	0	RW	0 : VBUS OVP enabled (default) 1 : VBUS OVP disabled
0x13 in Page 2	6	VBUS_OVP_NODEB	0	RW	0 : 25 μ s deglitch for VBUS OVP (default) 1 : No deglitch for VBUS OVP
	5:4	VBUS_OVP_SEL	10	RW	VBUS over-voltage protection level percentage. $OVP = VBUS_VOL_SEL * (100 + X)\%$ 00 : X = 5 01 : X = 10 10 : X = 15 (default) 11 : X = 20
	3:0	VBUS_VOL_SEL	1000	RW	VBUS voltage range 0000 : 5V 0001 : 6V 1000 : 13V (default) 1110 : 19V 1111 : 20V
0x15	2	M_VBUS_OV	1	RW	0 : Interrupt masked 1 : Interrupt unmasked (default)
0x1F	2	VBUS_OV	0	RW	0 : Not in an OV protection state (default) 1 : Over-Voltage fault latched

VCONN

• VCONN OCP

When VCONN_EN (0x1C[0] = 1b) and VCONN_OC enabled (0x1B[0] = 0b), VCONN_OC of fault status (0x1F[1]) will be 1b and there is no VCONN output if VCONN current (from VCONN to CC pin) is over the threshold (0x8C[7:5]).

Address	Bit	Bit Name	Default	Type	Description
0x1B	0	DIS_VCONN_OC	0	RW	0 : Fault detection circuit enabled (default) 1 : Fault detection circuit disabled
0x8C	7:5	VCONN_OCP_SEL	010	RW	PD_VCONN OCP level selection 000 : 100mA 001 : 200mA 010 : 300mA (default) 011 : 400mA 100 : 500mA 101 : 600mA 110 : 700mA 111 : 800mA
0x15	1	M_VCONN_OC	1	RW	0 : Interrupt masked 1 : Interrupt unmasked (default)
0x1F	1	VCONN_OC	0	RW	0 : No fault detected (default) 1 : Over-current VCONN fault latched

• VCONN OVP

When VCONN_OVP_EN_CC1 is enabled (0x8B[7] = 1b), VCONN_OV_CC1 (0xA0[0]) and INT_VCONN_OV_CC1 (0x99[0]) will be 1b and there is no VCONN output if the voltage at CC1 is higher than 5.75V (typical). VCONN_OV_CC1 becomes 0b when the voltage at CC1 is lower than 5.7V. When VCONN_OVP_EN_CC2 is enabled (0x8B[6] = 1b), VCONN_OV_CC2 (0xA0[1]) and INT_VCONN_OV_CC2 (0x99[1]) will be 1b and there is no VCONN output if the voltage at CC2 is higher than 5.75V (typical). VCONN_OV_CC2 becomes 0b when the voltage at CC2 is lower than 5.7V.

Address	Bit	Bit Name	Default	Type	Description
0x8B	7	VCONN_OVP_EN_CC1	0	RW	Enable CC1 OVP. The OVP threshold is 5.75V at CC1. 0 : Disable (default) 1 : Enable
	6	VCONN_OVP_EN_CC2	0	RW	Enable CC2 OVP. The OVP threshold is 5.75V at CC2. 0 : Disable (default) 1 : Enable
0x92	1	M_VCONN_OV_CC2	0	RW	0 : Interrupt masked (default) 1 : Interrupt unmasked
	0	M_VCONN_OV_CC1	0	RW	0 : Interrupt masked (default) 1 : Interrupt unmasked

Address	Bit	Bit Name	Default	Type	Description
0x99	1	INT_VCONN_OV_CC2	0	RW	0 : Cleared (default) 1 : CC2 OVP event is detected.
	0	INT_VCONN_OV_CC1	0	RW	0 : Cleared (default) 1 : CC1 OVP event is detected.
0xA0	1	VCONN_OV_CC2	0	R	0 : CC2 voltage is lower than 5.7V. (default) 1 : CC2 voltage is higher than 5.75V. Note : This bit works when VCONN_OVP_EN_CC2 is enabled.
	0	VCONN_OV_CC1	0	R	0 : CC1 voltage is lower than 5.7V. (default) 1 : CC1 voltage is higher than 5.75V. Note : This bit works when VCONN_OVP_EN_CC1 is enabled.

• **VCONN RVP**

When VCONN_RVP_EN is enabled (0x8B[3] = 1b), VCONN_RVP (0xA0[2]) and INT_VCONN_RVP (0x99[2]) will be 1b and there is no VCONN output if the voltage at CC (depending on 0x19[0]) is higher than VCONN by the voltage (0x8B[2]). VCONN_RVP becomes 0b when the voltage at CC is lower than VCONN by 50mV.

Address	Bit	Bit Name	Default	Type	Description
0x8B	5:4	VCONN_SHT_GND_TIMER	10	RW	When VCONN_EN = 1 (0x1E[0] = 1b), VCONN_SHT_GND will be 1 (0xA0[5] = 1b) if VCONN_PRESENT is always 0 and lasts for VCONN_SHT_GND_TIMER. 00 : 0.5ms 01 : 0.75ms 10 : 1ms (default) 11 : 3ms
	0	VCONN_SOFTEND_TIMER	0	RW	The time for which VCONN current limit is enabled after VCONN EN (0x1C[0] = 1b) 0 : 3ms (default) 1 : 5ms
0x92	5	M_VCONN_SHT_GND	0	RW	0 : Interrupt masked (default) 1 : Interrupt unmasked
0x99	5	INT_VCONN_SHT_GND	0	RW	0 : Cleared (default) 1 : VCONN RVP event is detected.
0xA0	5	VCONN_SHT_GND	0	R	VCONN-short-to-GND means VCONN at CC is not higher than 2.4V after VCONN_SHT_GND_TIMER when VCONN_EN is enabled. 0 : No VCONN short to GND (default) 1 : VCONN short to GND

• VCONN Short to GND

INT_VCONN_SHT_GND (0x99[5]) will be 1b and there is no VCONN output if the voltage at CC (depending on 0x19[0]) is lower than VCONN present (2.4V) with the timeout of VCONN_SHT_GND_TIMER (0x8B[5:4]) which started from VCONN_EN = 1b. Even though the voltage at CC (depending on 0x19[0]) is higher than VCONN present (2.4V) with the timeout of VCONN_SHT_GND_TIMER (0x8B[5:4]), INT_VCONN_SHT_GND (0x99[5]) will still be 1b and there is no VCONN output if the voltage at CC (depending on 0x19[0]) is lower than VCONN present (2.4V) with the timeout of VCONN_SOFTEND_TIMER (0x8B[0]) which started from VCONN_EN = 1b.

Address	Bit	Bit Name	Default	Type	Description
0x8B	5:4	VCONN_SHT_GND_TIMER	10	RW	When VCONN_EN = 1 (0x1E[0] = 1b), VCONN_SHT_GND will be 1 (0xA0[5] = 1b) if VCONN_PRESENT is always 0 and lasts for VCONN_SHT_GND_TIMER. 00 : 0.5ms 01 : 0.75ms 10 : 1ms (default) 11 : 3ms
	0	VCONN_SOFTEND_TIMER	0	RW	The time for which VCONN current limit is enabled after VCONN EN (0x1C[0] = 1b.) 0 : 3ms (default) 1 : 5ms
0x92	5	M_VCONN_SHT_GND	0	RW	0 : Interrupt masked (default) 1 : Interrupt unmasked
0x99	5	INT_VCONN_SHT_GND	0	RW	0 : Cleared (default) 1 : VCONN Pre short to ground
0xA0	5	VCONN_SHT_GND	0	R	VCONN-short-to-GND means VCONN at CC is not higher than 2.4V after VCONN_SHT_GND_TIMER when VCONN_EN is enabled. 0 : No VCONN short to GND (default) 1 : VCONN short to GND

• **VCONN UVP**

INT_VCONN_UVP (0x99[4]) will be 1b and there is no VCONN output if the voltage at CC (depending on 0x19[0]) is between 2.4V and VCONN_UVP_SEL (0x8A[5]) with the timeout of VCONN_SOFTEND_TIMER (0x8B[0]) which started from VCONN_EN = 1b. VCONN output is successful if the voltage at CC is higher than VCONN_UVP_SEL (0x8A[5]) with the timeout of VCONN_SOFTEND_TIMER (0x8B[0]). After that, INT_VCONN_UVP (0x99[4]) will be 1b and there is no VCONN output if the voltage at CC is lower than VCONN_UVP_SEL (0x8A[5]).

Address	Bit	Bit Name	Default	Type	Description
0x8A	5	VCONN_UVP_SEL	0	RW	VCONN UVP level selection 0 : 2.7V (default) 1 : 2.4V
0x8B	0	VCONN_SOFTEND_TIMER	0	RW	The time for which VCONN current limit is enabled after VCONN EN (0x1C[0] = 1b). 0 : 3ms (default) 1 : 5ms
0x92	4	M_VCONN_UVP	0	RW	0 : Interrupt masked (default) 1 : Interrupt unmasked
0x99	4	INT_VCONN_UVP	0	RW	0 : Cleared (default) 1 : VCONN voltage less than VCONN_INVALID (2.7V) when VCONN_UVP_SEL = 0 (0x8A[5]), or VCONN voltage less than VCONN_PRESENT (2.4V) when VCONN_UVP_SEL = 1 (0x8A[5])
0xA0	4	VCONN_UVP	0	R	VCONN under voltage protect 0 : VCONN voltage at CC is higher than VCONN_INVALID (2.7V) when VCONN_UVP_SEL = 0 (0x8A[5]), or VCONN voltage higher than VCONN_PRESENT (2.4V) when VCONN_UVP_SEL = 1 (0x8A[5]) (default) 1 : VCONN voltage at CC is less than VCONN_INVALID(2.7V) when VCONN_UVP_SEL = 0 (0x8A[5]), or VCONN voltage less than VCONN_PRESENT (2.4V) when VCONN_UVP_SEL = 1 (0x8A[5])

SBU and DPDM Switches

- SBU and DPDM Switches Control**

SBU and DPDM switches are on and the OVP function is on as VCC powers on. To control the DP/DM Switch and SBU Switch, the RT1718S must be in Non-SHIPPING Mode (0x8F[5] = 1b).

To turn on SBU switches, the SBU switches OVP source must be on (0xF23A[7] = 1b). SBU2 switch and SBU1 switch can be controlled independently (0xF23A[3] for SBU2 and 0xF23A[2] for SBU1).

To turn on DPDM switches, the DPDM switches OVP source must be on (0xF23A[6] = 1b). DM switch and DP switch can be controlled independently (0xF23A[1] for DM and 0xF23A[0] for DP).

Addr	Length	RegName	Bit	BitName	Default	Type	Description
0x3A in Page 2	1	SBU_CTRL_01	7	SBU_VIEN	1	RW	SBU protection VI source enable 0 : Disable 1 : Enable (default)
			6	DPDM_VIEN	1	RW	DPDM protection VI source enable 0 : Disable 1 : Enable (default)
			5:4	Reserved	00	R	Reserved
			3	SBU2_SWEN	1	RW	SBU2 switch enable 0 : Disable 1 : Enable (default)
			2	SBU1_SWEN	1	RW	SBU1 switch enable 0 : Disable 1 : Enable (default)
			1	DM_SWEN	1	RW	DM switch enable 0 : Disable 1 : Enable (default)
			0	DP_SWEN	1	RW	DP switch enable 0 : Disable 1 : Enable (default)

• 4-Channels USB and SBU Switch Input Over-Voltage Protection

The RT1718S has 4-channels of Short to VBUS overvoltage protection for the DP, DM, SBU1 and SBU2 pins of the USB Type-C receptacle via internal OVP level. When the input voltage exceeds the OVP level, the RT1718S will ultra-fast turn off internal switches around 60ns to prevent the high input voltage from damaging the end system. When the DPDM/SBU input voltage returns to normal operation voltage range with hysteresis 60mV, the will turn on the switches to turn on channel.

The switch turned off by OVP will recover to being on after the recovery time (0xF23C[5:4].) As the recovery time expires and there is no OV fault at the switch, the switch will be on automatically. The recovery time can be started at rising or falling of OV event (0xF23C[3]).

If any one of channel voltage exceeds OVP threshold, the channel switch will be turned off and the others switches status depend on the register setting 0xF23C[2:0].

Addr	Length	RegName	Bit	BitName	Default	Type	Description
0x3C in Page 2	1	SBU_ CTRL_03	5:4	SBUDPDM_REC_ TIME	00	RW	DPDM OVP recovery time 00 : 400μs (default) 01 : 600μs 10 : 800μs 11 : 1000μs Note : ±8μs
			3	SBUDPDM_REC_ TYPE	0	RW	SBU OVP recovery type select 0 : Recovery time starts at OV rising (default) 1 : Recovery time starts at OV falling
			2	VCONN_OV_OFF	0	RW	Switch off when VCONN OV 0 : Turn off VCONN (default) 1 : Turn off SBU1/SBU2/DP/DM/VCO NN
			1	DPDM_OV_OFF	0	RW	Switch off when DPDM OV 0 : Turn off DP/DM (default) 1 : Turn off SBU1/SBU2/DP/DM/VCO NN
			0	SBU_OV_OFF	0	RW	Switch off when SBU OV 0 : Turn off SBU1/SBU2 (default) 1 : Turn off SBU1/SBU2/DP/DM/VCO NN

The OVP status and switch status can be checked in register 0xF23D. If one of switch OVP status (0xF23D[7:4]) changes, the INT_SBUDPDM_SW will be 1b (0x9D[2] = 1b).

Addr	Length	RegName	Bit	BitName	Default	Type	Description
0x3D in Page 2	1	SBUDPDM_OV_STS	7	SBU2_OV_FLAG	0	R	SBU2 OVP status 0 : No OVP occur (default) 1 : OVP occur
			6	SBU1_OV_FLAG	0	R	SBU1 OVP status 0 : No OVP occur (default) 1 : OVP occur
			5	DM_OV_FLAG	0	R	DM OVP status 0 : No OVP occur (default) 1 : OVP occur
			4	DP_OV_FLAG	0	R	DP OVP status 0 : No OVP occur (default) 1 : OVP occur
			3	STS_SBU2_SWEN	0	R	SBU2 switch status 0 : Switch off (default) 1 : Switch on
			2	STS_SBU1_SWEN	0	R	SBU1 switch status 0 : Switch off (default) 1 : Switch on
			1	STS_DM_SWEN	0	R	DM switch status 0 : Switch off (default) 1 : Switch on
			0	STS_DP_SWEN	0	R	DP switch status 0 : Switch off (default) 1 : Switch on
0x96	1	RT_MASK6	2	M_SBUDPDM_SW	0	RW	0 : Interrupt masked (default) 1 : Interrupt unmasked
0x9D	1	RT_INT6	2	INT_SBUDPDM_SW	0	RW	0 : Cleared (default) 1 : SBU/DPDM switch status change

The OVP threshold range of the SBU switch is from 3.6V to 4.5V, which can be set at register 0xF23F[7:6]. It is recommended that set OVP threshold of SBU switch as 4.5V (0xF23F[7:6] = 11b) for better compliance. The OVP threshold of DPDM switches is 4.5V.

Addr	Length	RegName	Bit	BitName	Default	Type	Description
0x3F in Page 2	1	SBU_CTRL_04	7:6	SBU_OV_SEL	10	RW	SBU1/SBU2 OVP level select 00 : 3.6V 01 : 3.7V 10 : 3.8V (default) 11 : 4.5V

Source Detection

The source detection function is used in UFP-powered application. The GPIO3 (for sink path) will be high (0xEF = 0Eh) if the Rp level is 1.5A or 3A. The setting is according to the resistance on SRCDET (pin 14). The setting status is reported in SRCDET_SETTING (0xF2C1[5:4]). For Source detection function, the power of VCCIO (pin 24) is recommended from VCCO and VCC as shown in sink application circuit. If the RT1718S is soft-reset (0xB0[0] = 1b) during the general operation after power on, the GPIO3 setting (0xEF) and the driving ability of GPIO3 (0xF2C0[5:4]) are able to not reset depending on GPIO3_SOFT_RSTN_EN (0xF2C1[1] = 0b). The Source detection function can be disabled in SRCDET_CTRL_EN (0xF2C1[0] = 0b) even though the setting on SRCDET (pin 14) is enabled.

Resistance between SRCDET and GND (Unit : kΩ)	Function	0xF2C1[5:4]
0	SRCDET disabled	00b
309	GPIO3 is high if 1.5A or 3A Rp attached	01b
649	GPIO3 is high if 3A Rp attached	10b
open	Disabled	00b

Addr	Length	Bit	BitName	Default	Type	Description
0xC1 in Page 2	1	5:4	SRCDET_SETTING	00	R	SRCDET setting 00 : No SRCDET function (default) 01 : Check CC for 1.5A 10 : Check CC for 3.0A 11 : Reserved
		1	GPIO3_SOFT_RSTN_EN	1	RW	GPIO3_SOFT_RSTN_EN, Reset REG 0xEF[3:1] (GPIO3_OD_N, GPIO3_OE, GPIO3_O), RT2_REG 0xC0[5:4] GPIO3_DRV, when soft reset trigger 0 : Disable 1 : Enable (default)
		0	SRCDET_CTRL_EN	1	RW	SRCDET_CTRL_EN, Turn on VBUS (GPIO3) when special RP level attach, depend on SRCDET PIN 0 : Disable 1 : Enable (default)

BC1.2 General Description

The BC1.2 specification defines the mechanisms to permit USB devices to draw current higher than standard USB current : 900mA for USB3.0 and 500mA for USB2.0. According to BC1.2 spec, the devices can draw up to 1.5 A of current. The detection and the advertisement of the higher current capable port are through USB2.0 D+ and D- lines upon connection. There are three charging ports defined in the BC1.2 spec : Dedicated Charging Port (DCP), Charging Downstream Port (CDP) and Standard Downstream Port (SDP). The RT1718S supports both portable device role (sink role) and downstream port or charging downstream port (source role.) BC1.2 function can work only with DPDM switches on (0xF23A[6] = 1b and 0xF23A[1:0] = 11b).

- **DPDM BC1.2 Sink Role**

The RT1718S supports BC1.2 Sink Role, Data Contact Detection (DCD) and DP 2.7V to 1.2V TA detection (TA detection for short.) DCD and TA detection can work only with BC1.2 sink role enabled (0xF260[7] = 1b). The detection results are reported in BC12_STAT (0xF261[5:0].) This status register will be set to 00h after detachment. If the BC1.2 sink flow is done, it will be reported in RT_ST6 (0xA4[7]) and inform the master by IRQB (0x9D[7]). The HVDCP is also particularly reported in RT_ST6 (0xA4[6]) and inform the master by IRQB (0x9D[6]). The BC1.2 sink flow status and HVDCP status (0xA4[7:6]) will be 00b after detachment. The following four diagrams show the detection flows depending on the enabled detection functions.

BC12 Enable, Reg 0xF260[7] = 1b
 SPEC_TA_EN, Reg 0xF260[6] = 1b
 DCD SEL, Reg 0xF260[5:4] = 10b & 01b
 Wait Vbus, Reg 0xF260[1] = 1b

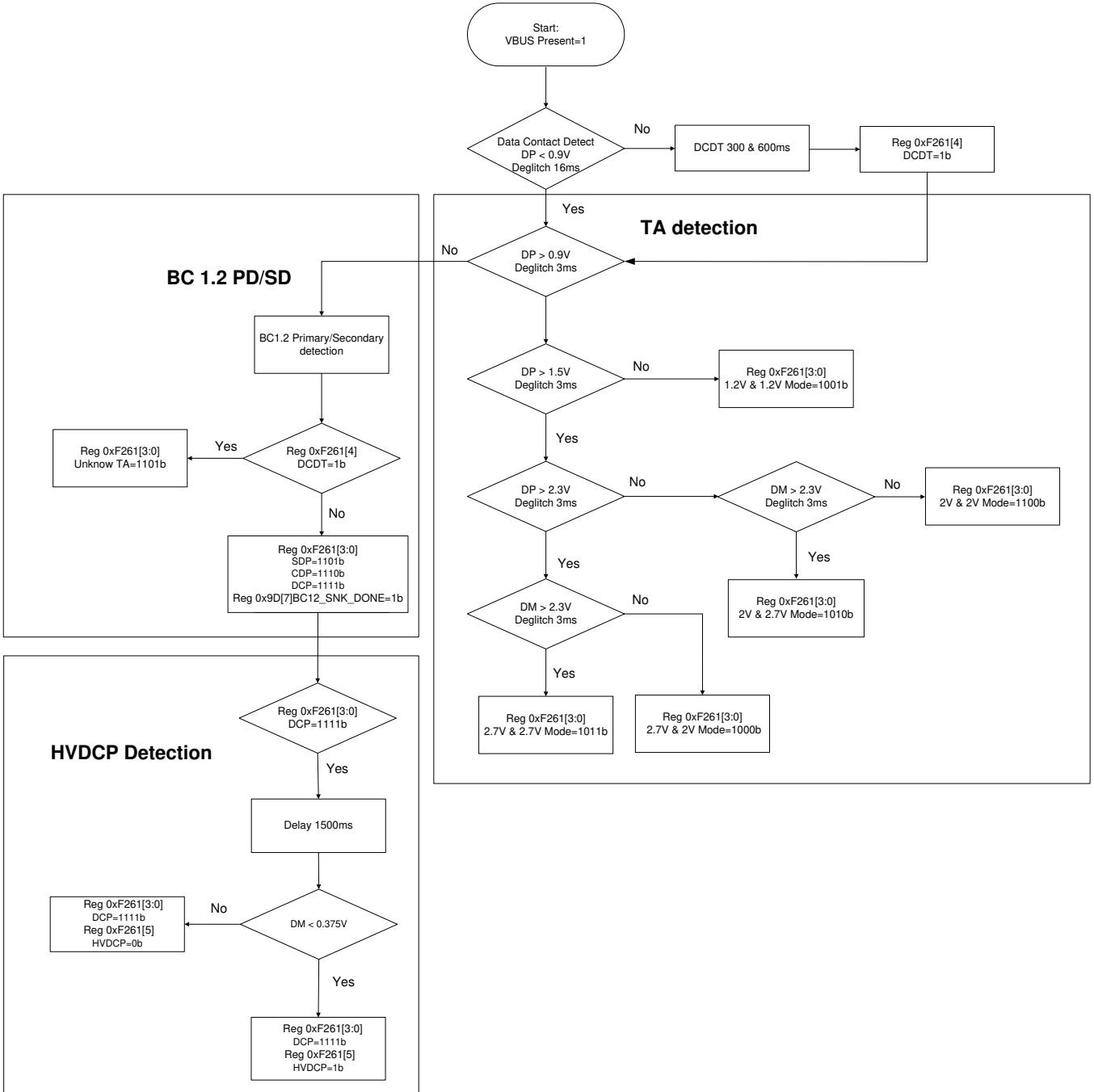

BC12 Enable, Reg 0xF260[7] = 1
 SPEC_TA_EN, Reg 0xF260[6] = 1
 DCD SEL, Reg 0xF260[5:3] = 00
 (DCD disable)
 Wait Vbus, Reg 0xF260[1] = 1b

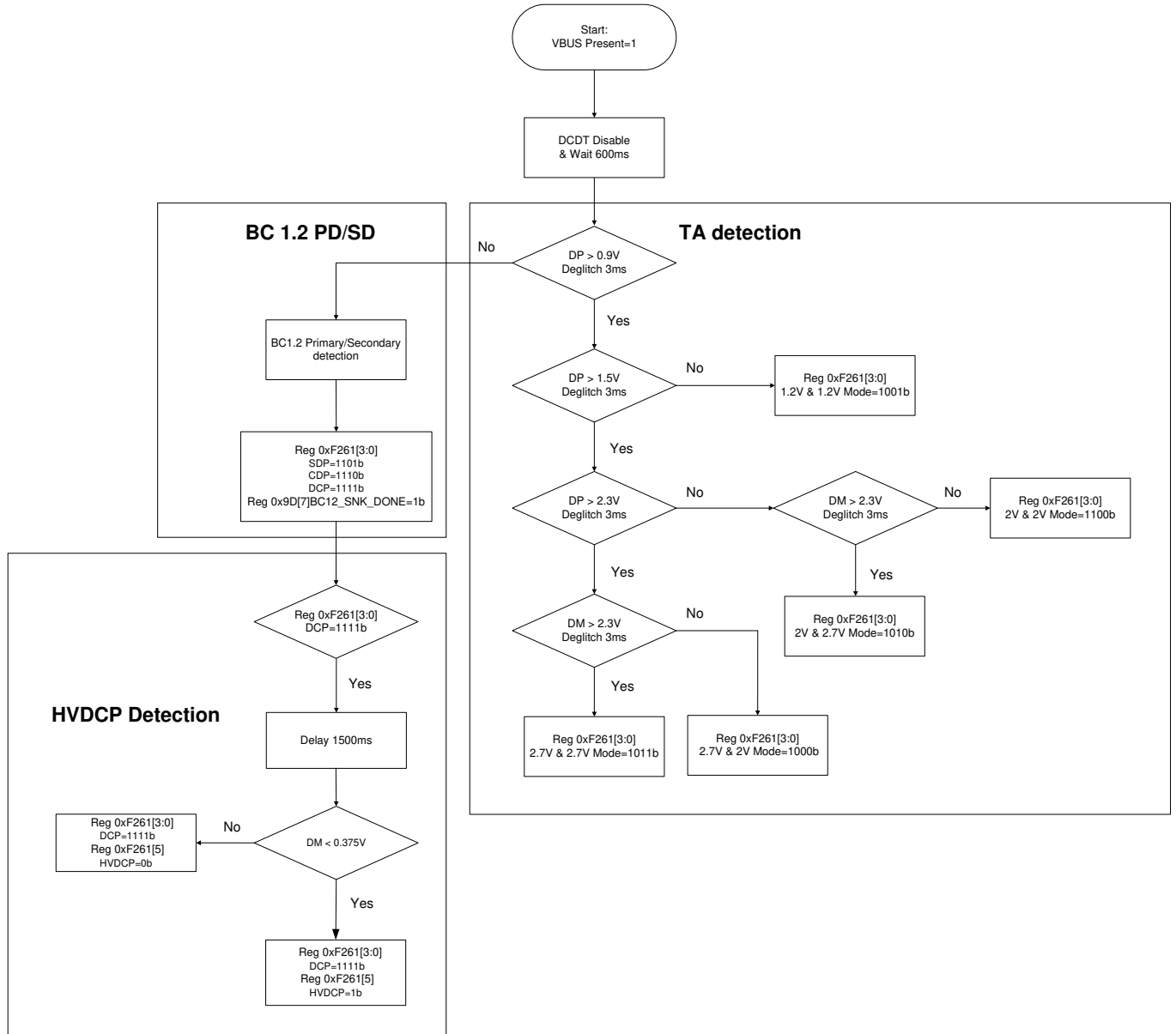

**BC12 Enable , Reg 0xF260[7] = 1
 SPEC_TA_EN , Reg 0xF260[6] = 0
 DCD SEL , Reg 0xF260[5:3] = 10 & 01
 Wait Vbus, Reg 0xF260[1] = 1b**

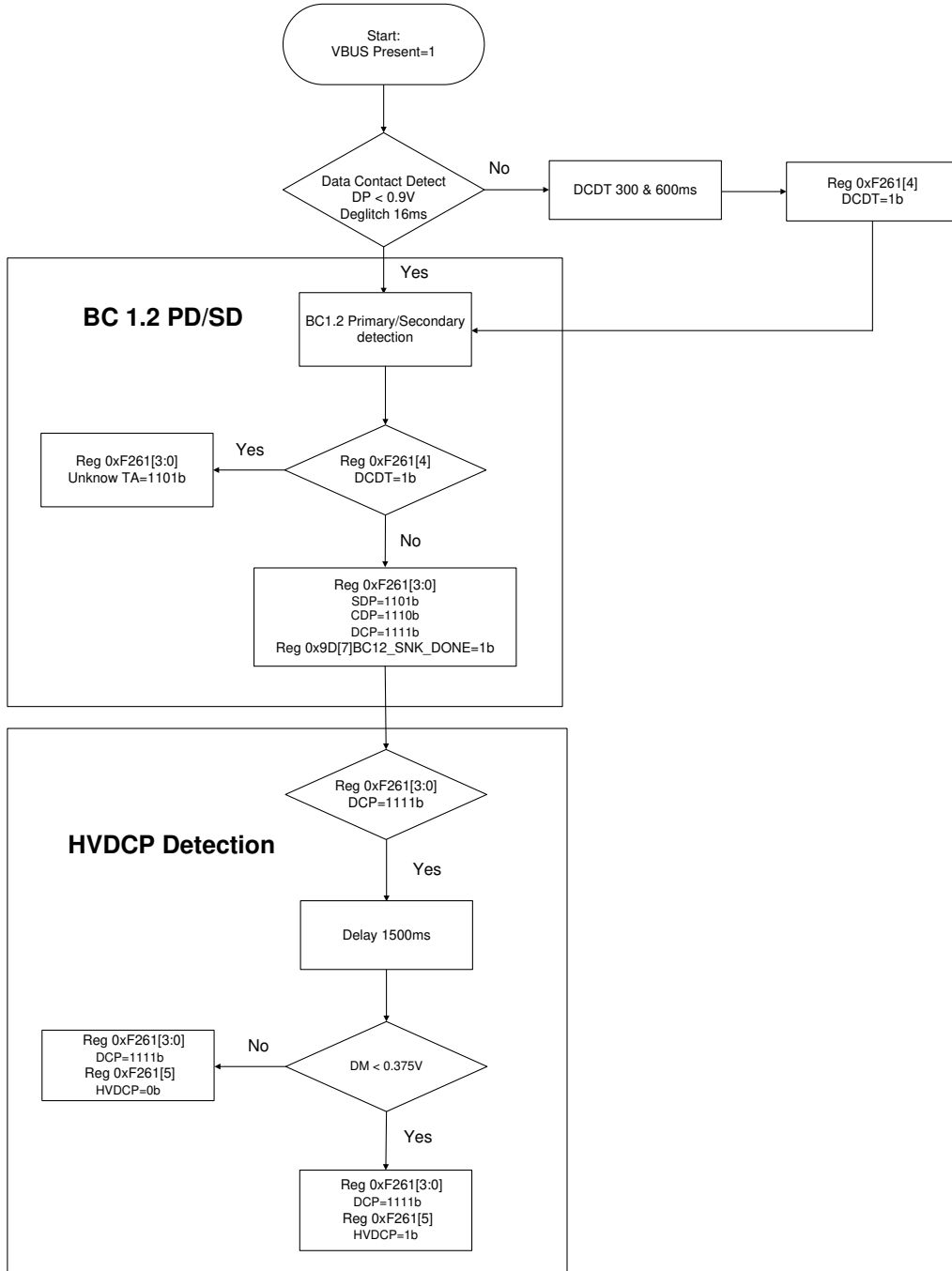

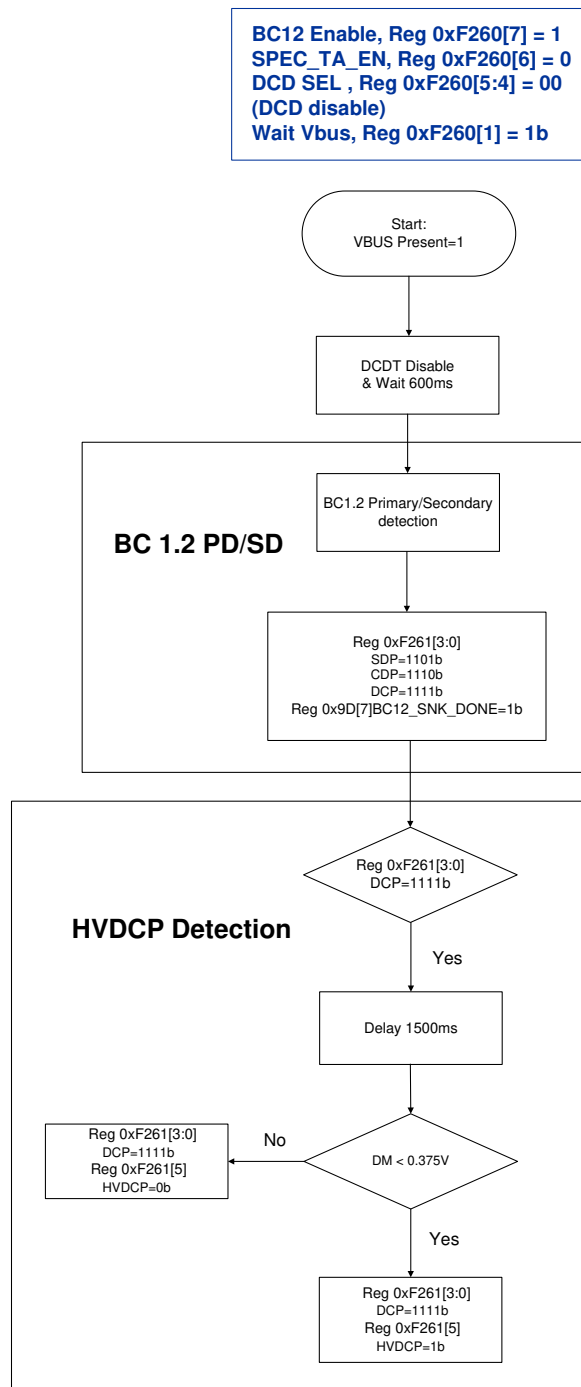

Addr	Length	Bit	BitName	Default	Type	Description
0x3A in Page 2	1	6	DPDM_VIEN	0	RW	DPDM protection VI source enable 0 : Disable (default) 1 : Enable
		1	DM_SWEN	0	RW	DM switch enable 0 : Disable (default) 1 : Enable
		0	DP_SWEN	0	RW	DP switch enable 0 : Disable (default) 1 : Enable
0x60 in Page 2	1	7	BC12_SNK_EN	0	RW	Enable BC12 Sink side function 0 : Disable (default) 1 : Enable
		6	SPEC_TA_EN	0	RW	Enable DPDM 2.7V ,1.2V mode TA detection 0 : Disable (default) 1 : Enable
		5:4	DCDT_SEL	10	RW	DCD timeout function select 00 : Disable dcd timeout function 01 : Enable 300ms dcd timeout function 10 : Enable 600ms dcd timeout function (default) 11 : Wait data contact
		1	BC12_WAIT_VBUS	0	RW	BC12 sink function wait and check VBUS 0 : Not wait VBUS > 3.8V (default) 1 : Wait and check VBUS When this bit set to 1'b1, BC12 sink function will be enabled when VBUS > 3.8V. And BC12 Sink function will be disabled when VBUS < 3.6V.

Addr	Length	Bit	BitName	Default	Type	Description
0x61 In Page 2	1	5	HVDCP	0	R	0 : TA is not HVDCP (default) 1 : TA is HVDCP
		4	DCDT	0	R	0 : DCD without time out (default) 1 : DCD time out
		3:0	PORT_STAT	0000	R	0000 : No information (default) 1000 : VBUS = device 1 (2.7V & 2V mode) 1001 : VBUS = device 2 (1.2V & 1.2V mode) 1010 : VBUS = device 3 (2V & 2.7V mode) 1011 : VBUS = device 4 (2.7V & 2.7V mode) 1100 : VBUS = device 5 (2V & 2V mode)/unknown TA (500mA) 1101 : VBUS = SDP (500mA) 1110 : VBUS = CDP (1500mA) 1111 : VBUS = DCP (2400mA)
0x96	1	7	M_BC12_SNK_DONE	0	RW	0 : Interrupt masked (default) 1 : Interrupt unmasked
		6	M_HVDCP_CHK_DONE	0	RW	0 : Interrupt masked (default) 1 : Interrupt unmasked
0x9D	1	7	INT_BC12_SNK_DONE	0	RW	0 : Cleared (default) 1 : BC12 sink flow done
		6	INT_HVDCP_CHK_DONE	0	RW	0 : Cleared (default) 1 : HVDCP flow check done (sink side)
0xA4	1	7	BC12_SNK_DONE	0	R	0 : Cleared (default) 1 : BC12 sink flow done
		6	HVDCP_CHK_DONE	0	R	0 : Cleared (default) 1 : HVDCP flow check done (sink side)

• **2.7V & 1.2V Mode Chargers Detection**

The following table shows the source ability if the source advertisement is according to the voltages of DP and DM.

0xF261[3:0]	Voltage on D+ (V)	Voltage on D- (V)	Charging Current (A)	Comments
1000b	2.7	2	2	2.7V & 2V Mode
1001b	1.2	1.2	2	1.2V & 1.2V Mode
1010b	2	2.7	1	2V & 2.7V Mode
1011b	2.7	2.7	2.4	2.7V & 2.7V Mode
1100b	2	2	0.5	2V & 2V Mode

• **DPDM BC1.2 SRC Role**

The RT1718S supports BC1.2 source role (SDP, CDP, and DCP.) To enable BC1.2 source role, set BC12_SRC_EN as 1b (0xF26D[7] = 1b). Set the source role mode in SRC_MODE_SEL (0xF26D[6:4]).

As a CDP, the DP voltage should be between DPDM_VOL_L (0xF273[4:0]) and DOPDM_VOL_H (0xF272[4:0]) as well as the time width of DP should be between the CDP_VSRC_ON_SEL (0xF270[1:0]) and PRIMARY_TIMEOUT_SEL (0xF270[3:2]) during the primary detection, or the STS_CDP_DONE (0xF26[0]) will be 0b. The time width of DM of RT1718S will be equal to that of DP if the time width of DP is less than PRIMARY_TIMEOUT_SEL (0xF270[3:2]). After the valid primary detection (DP falling), the USBDET_TIMEOUT_SEL (0xF270[5:4]) timer will start. If DP is not higher than DPDM_VOL_H2 (0xF271[4:0]) between secondary detection done and USBDET_TIMEOUT_SEL timeout, the STS_CDP_ERR (0xF26[1]) will be 1b and the STS_CDP_DONE (0xF26[0]) will be 0b. If DP is higher than DPDM_VOL_H2 (0xF271[4:0]) between secondary detection done and USBDET_TIMEOUT_SEL timeout, the STS_CDP_ERR (0xF26[1]) will be 0b and the STS_CDP_DONE (0xF26[0]) will be 1b.

Any changes in STS_CDP_ERR (0xF26[1]) or STS_CDP_DONE (0xF26[0]) will set INT_BC12_TA_CHG (0x9D[5]) as 1b.

Addr	Length	Bit	BitName	Default	Type	Description
0x6D in Page 2	1	7	BC12_SRC_EN	0	RW	BC12 TA function enable 0 : Disable (default) 1 : Enable
		6:4	SRC_MODE_SEL	000	RW	Mode select 000 : BC12 SDP (default) 001 : BC12 CDP 010 : BC12 DCP 011 to 111 : Reserved
		0	WAIT_VBUS_ON	1	RW	Wait VBUS > 4.0V (VBUS_PRESENT_FLAG = 1) to enable BC12 TA function 0 : Not wait VBUS > 4.0V. BC12 TA function will enable when BC12_SRC_EN = 1b 1 : Wait VBUS > 4.0V. BC12 TA function will enable when BC12_SRC_EN = 1b and VBUS_PRESENT_FLAG = 1 (default)
0x70 in Page 2	1	5:4	USBDET_TIMEOUT_SEL	10	RW	USB device detect timeout 00 : 1.024s 01 : 2.048s 10 : 4.096s (default) 11 : 8.192s
		3:2	PRIMARY_TIMEOUT_SEL	00	RW	Primary detection timeout 00 : 1.0s (default) 01 : 1.3s 10 : 1.6s 11 : 2.0s
		1:0	CDP_VSRC_ON_SEL	10	RW	Vsrc_on time detect 00 : 16ms 01 : 24ms 10 : 32ms (default) 11 : 40ms

Addr	Length	Bit	BitName	Default	Type	Description
0x71 in Page 2	1	4:0	DPDM_VOL_H2	10011	RW	<p>DPDM voltage detection setting (HI/LO) Threshold : 0.1V to 2.6V (LSB = 0.1V) 00000 : 0.1V ... 10011 : 2.0V (default) ... 11001 : 2.6V ----- 11010 : 0.275V (BC1.2 VDAT_REF_MIN) 11011 : 0.375V (BC1.2 VDAT_REF_MAX) 11100 : 0.9V (BC1.2 VLGC_MIN) 11101 : 1.975V (BC1.2 VLGC_MAX) 11110 : 1.5V (A_DET_LO) 11111 : 2.3V (A_DET_HI) Note : In CDP mode, this register is used to check USB attach level. In private protocol mode/Auto TA mode, this register is used to check DPDM high level after device attach.</p>
0x72 in Page 2	1	4:0	DPDM_VOL_H	01001	RW	<p>DPDM voltage detection setting (HI/LO) Threshold : 0.1V to 2.6V (LSB = 0.1V) 00000 : 0.1V ... 01001 : 1.0V(default) ... 11001 : 2.6V ----- 11010 : 0.275V (BC1.2 VDAT_REF_MIN) 11011 : 0.375V (BC1.2 VDAT_REF_MAX) 11100 : 0.9V (BC1.2 VLGC_MIN) 11101 : 1.975V (BC1.2 VLGC_MAX) 11110 : 1.5V (A_DET_LO) 11111 : 2.3V (A_DET_HI) Note : This register is used for CDP/private protocol to check Vdp_src high level.</p>

Addr	Length	Bit	BitName	Default	Type	Description
0x73 in Page 2	1	4:0	DPDM_VOL_L	11010	RW	DPDM voltage detection setting (HI/LO) Threshold : 0.1V to 2.6V (LSB = 0.1V) 00000 : 0.1V ... 11001 : 2.6V ----- 11010 : 0.275V (BC1.2 VDAT_REF_MIN) (default) 11011 : 0.375V (BC1.2 VDAT_REF_MAX) 11100 : 0.9V (BC1.2 VLGC_MIN) 11101 : 1.975V (BC1.2 VLGC_MAX) 11110 : 1.5V (A_DET_LO) 11111 : 2.3V (A_DET_HI) Note : This register is used for CDP/ private protocol to check Vdp_src high level.
0x6E in Page 2	1	1	STS_CDP_ERR	0	R	CDP flow error 0 : No CDP flow error (default) 1 : CDP flow error Note : This bit is updated after INT_BC12_TA_CHG have been set to 1b. It will keep until next time INT_BC12_TA_CHG has set to 1b. Check this bit only after INT_BC12_TA_CHG have been set to 1b.
		0	STS_CDP_DONE	0	R	CDP flow done 0 : No CDP flow (default) 1 : CDP flow done Note : This bit is updated after INT_BC12_TA_CHG have been set to 1b. It will keep until next time INT_BC12_TA_CHG has set to 1b. Check this bit only after INT_BC12_TA_CHG have been set to 1b.
0x96	1	5	M_BC12_TA_CHG	0	RW	0 : Interrupt masked (default) 1 : Interrupt unmasked
0x9D	1	5	INT_BC12_TA_CHG	0	RW	0 : Cleared (default) 1 : BC12 source flow status change (CDP)
0xA4	1	5	BC12_TA_CHG	0	R	0 : Cleared (default) 1 : BC12 source flow status change (CDP/ private protocol) Note : This flag only keeps 0.33μs.

Outline Dimension

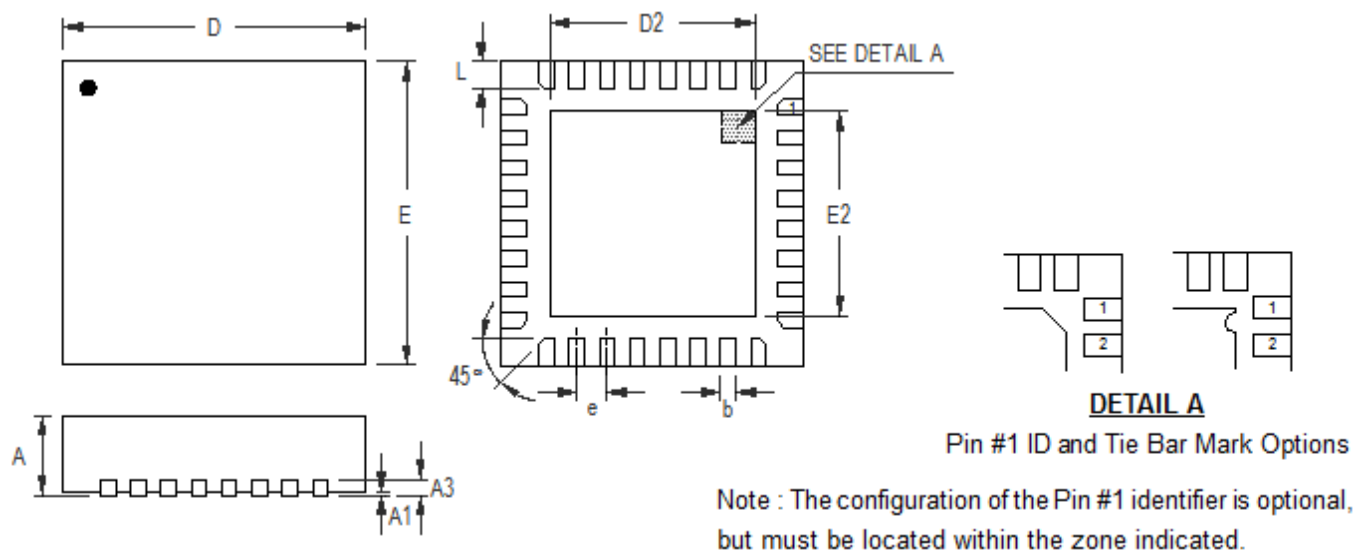

Symbol	Dimensions In Millimeters		Dimensions In Inches	
	Min	Max	Min	Max
A	0.700	0.800	0.028	0.031
A1	0.000	0.050	0.000	0.002
A3	0.175	0.250	0.007	0.010
b	0.150	0.250	0.006	0.010
D	3.900	4.100	0.154	0.161
D2	2.650	2.750	0.104	0.108
E	3.900	4.100	0.154	0.161
E2	2.650	2.750	0.104	0.108
e	0.400		0.016	
L	0.300	0.400	0.012	0.016

W-Type 32L QFN 4x4 Package

Footprint Information

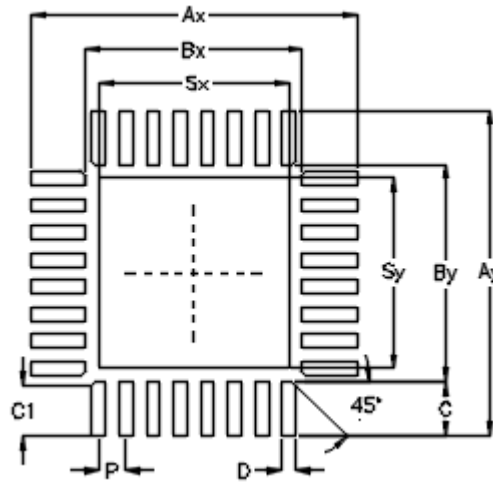

Package	Number of Pin	Footprint Dimension (mm)										Tolerance
		P	Ax	Ay	Bx	By	C*32	C1*8	D	Sx	Sy	
V/W/U/XQFN4*4-32	32	0.40	4.80	4.80	3.20	3.20	0.80	0.75	0.20	2.80	2.80	±0.05

Richtek Technology Corporation

14F, No. 8, Tai Yuen 1st Street, Chupei City

Hsinchu, Taiwan, R.O.C.

Tel: (8863)5526789

Richtek products are sold by description only. Richtek reserves the right to change the circuitry and/or specifications without notice at any time. Customers should obtain the latest relevant information and data sheets before placing orders and should verify that such information is current and complete. Richtek cannot assume responsibility for use of any circuitry other than circuitry entirely embodied in a Richtek product. Information furnished by Richtek is believed to be accurate and reliable. However, no responsibility is assumed by Richtek or its subsidiaries for its use; nor for any infringements of patents or other rights of third parties which may result from its use. No license is granted by implication or otherwise under any patent or patent rights of Richtek or its subsidiaries.

Copyright © 2022 Richtek Technology Corporation. All rights reserved. **RICHTEK** is a registered trademark of Richtek Technology Corporation.