

NOTES:

- MATERIALS AND FINISHES:
  - COVER - BRASS, GOLD PLATING
  - FERRULE - BRASS, GOLD PLATING
  - RETAINER RING - BERYLLIUM COPPER, NATURAL
  - HOUSING - ZINC ALLOY, GOLD PLATING
  - BODY - BRASS, GOLD PLATING
  - CONTACT - BERYLLIUM COPPER, GOLD PLATING
  - INSULATOR - PTFE, NATURAL

- ELECTRICAL:
  - A. IMPEDANCE: 50 OHM
  - B. FREQUENCY RANGE: 0-4 GHz
  - C. VSWR (RETURN LOSS): 1.500 (-13.979 dB) MAX.
  - D. D.W.V: 1000 VRMS, MIN.

- MECHANICAL:
  - A. DURABILITY: 500 CYCLES MIN.
  - B. TEMPERATURE RANGE: -65°C TO +165°C

4. CRIMPED FERRULE HEX CRIMP SIZE .128"

5. CONTACT PIN TO SOLDER.

6. SHOWS CABLE ENTRY DIMENSIONS.

THIRD ANGLE PROJ.

REVISIONS

REV	DESCRIPTION	DATE	ECO	APPR
A	UPDATED PART DIMENSIONS / DRAWING FORMAT	20-Mar-03	-----	GRS
B	REVISE BARREL, FERRULE DIMENSIONS	08-May-07	-----	GRS
C	REVISE HOUSING, BODY, FERRULE, COVER PLATING TO GOLD	12-Nov-08	-----	GRS
D	SYNC, THE HOUSING WAS RE-TOOLED\RD-DMI7042701M	05-May-17	03587	SH

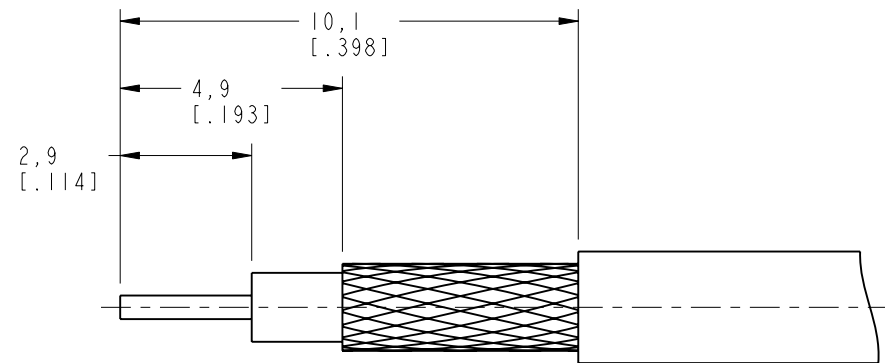

RECOMMENDED  
CABLE STRIPPING DIM'S

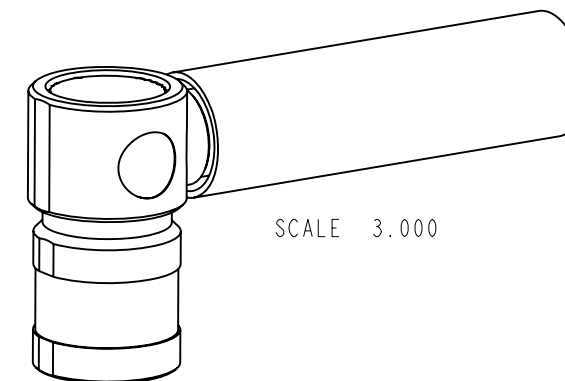

SCALE 3.000

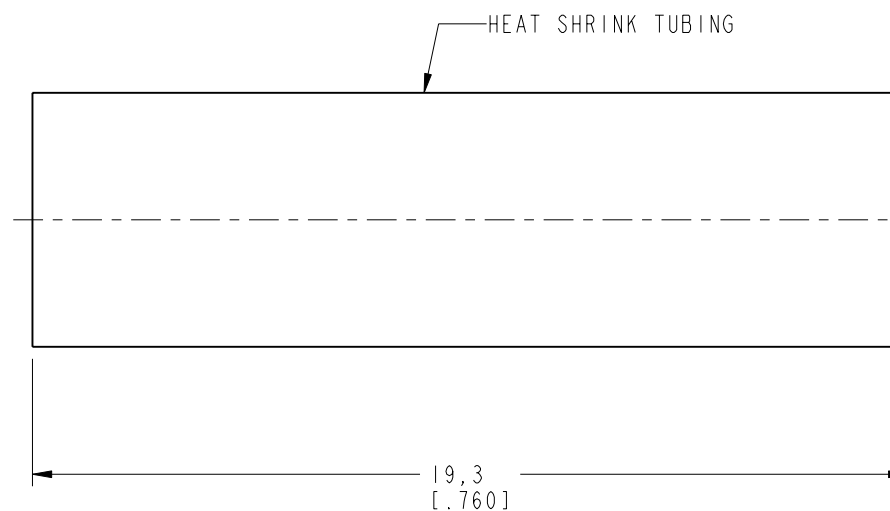
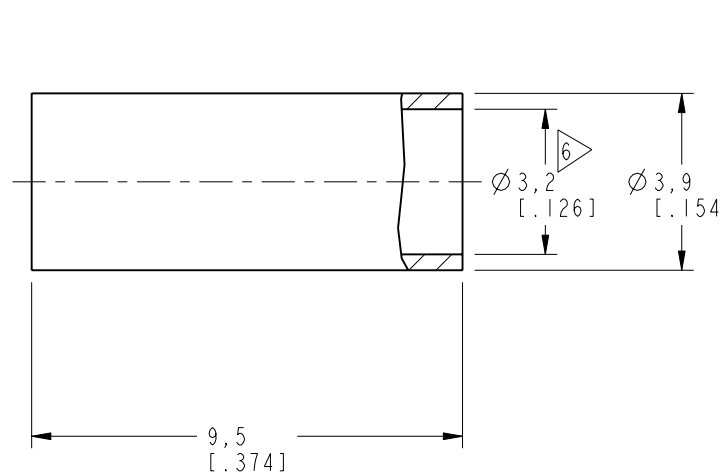
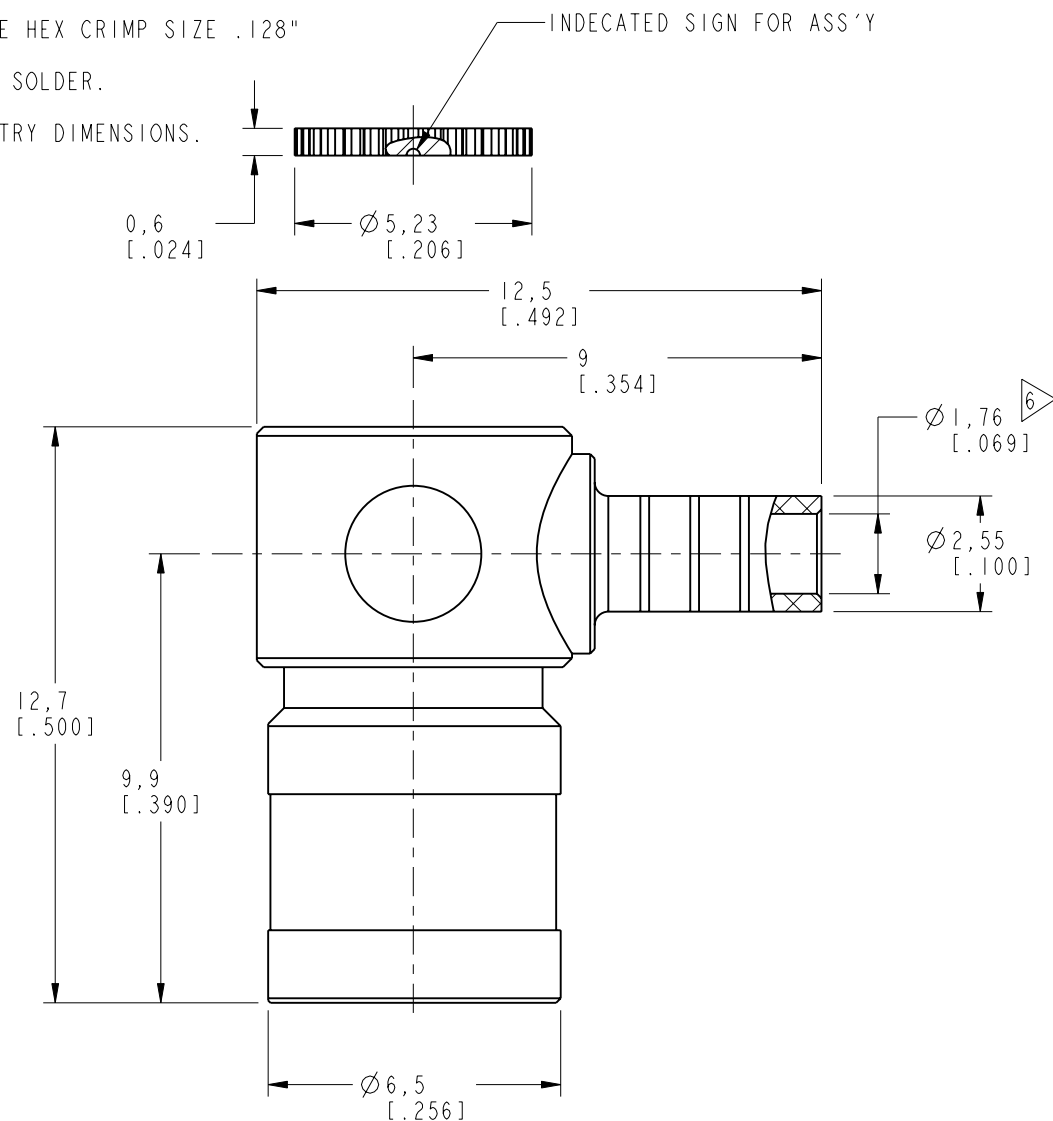

**CUSTOMER OUTLINE DRAWING**

ALL OTHER SHEETS ARE FOR INTERNAL USE ONLY

UNLESS OTHERWISE SPECIFIED, DIMENSIONS ARE IN METRIC AND TOLERANCES ARE:  
 < 0.5mm ± 0.05mm    0.5 - 6mm ± 0.1mm    6 - 30mm ± 0.2mm    30 - 120mm ± 0.3mm    ANGLES ± 1°

NOTICE - These drawings, specifications, or other data (1) are, and remain the property of Amphenol corp. (2) must be returned upon request; and (3) are confidential and not to be disclosed to any person other than those to whom they are given by Amphenol Corp. the furnishing of these drawings, specifications, or other data by Amphenol Corp., or to any other person to anyone for any purpose is not to be regarded by implication or otherwise in any manner licensing, granting rights to permitting such holder or any other person to manufacture, use or sell any product, process or design, patented or otherwise, that may in any way be related to or disclosed by said drawings, specifications, or other data.

MATERIAL	
REFERENCE AND CONFIGURATION LEVEL: In Work	
FINISH	

DRAWN M. ZHANG	DATE 05-May-17
ENGINEER C. WANG	DATE 20-Aug-07
APPROVED S. HSIEH	DATE 05-May-17
CAD FILE	

TITLE SMB R/A CRIMP PLUG (FOR RG-174/U, 188A/U 316/U CABLE)	
SCALE: 6.0:1.0	SHEET 2 OF 2
DWG SIZE B	REV D

Amphenol RF www.amphenolrf.com	
DRAWING NO. SMB6112D1-013-3GT30G-50	
ITEM NO.	126112AAT36GE5F
PART NO.	142194