

LTC3810 Current Mode Synchronous Switching Regulator Controller

DESCRIPTION

Demonstration circuit 952 is a current mode synchronous switching regulator featuring the LTC3810. The circuit is configured as a synchronous step-down regulator operating at 230kHz switching frequency. Output voltage is 12V at 6A maximum load. The input voltage range is 13V – 80V.

The operating mode can be selected with jumper JP1. Depending on the position of this jumper, at low load the circuit will operate in forced continuous mode (for best load transient response at low current) or in pulse skip mode (for best efficiency at low current). With jumper JP1 in the mid position the circuit can synchronize to an external clock signal on the Mode/Sync pin.

A Power Good output is provided. The PGOOD output is normally high, with a pull up resistor to VLOGIC. If the output voltage is not within $\pm 10\%$ of nominal value the PGOOD signal will go low.

The circuit can be synchronized to an external clock signal.

Design files for this circuit board are available. Call the LTC factory.

L, LTC, LTM, LT, Burst Mode, OPTI-LOOP, Over-The-Top and PolyPhase are registered trademarks of Linear Technology Corporation. Adaptive Power, C-Load, DirectSense, Easy Drive, FilterCAD, Hot Swap, LinearView, μ Module, Micropower SwitcherCAD, Multimode Dimming, No Latency $\Delta\Sigma$, No Latency Delta-Sigma, No R_{SENSE} , Operational Filter, PanelProtect, PowerPath, PowerSOT, SmartStart, SoftSpan, Stage Shedding, SwitcherCAD, ThinSOT, UltraFast and VLDO are trademarks of Linear Technology Corporation. Other product names may be trademarks of the companies that manufacture the products.

PERFORMANCE SUMMARY Specifications are at TA = 25°C

SYMBOL	PARAMETER	CONDITIONS	MIN	TYP	MAX	UNITS
V_{IN}	Input Supply Range		13		80	V
V_{OUT}	Output Voltage	$V_{IN} = 24V, I_{LOAD} = 100mA$	11.8	12	12.2	V
I_{OUT}	Output Current	$V_{IN} = 24V$	0		6	A
I_Q	Input Current In Shutdown	$V_{IN} = 24V, RUN/SS = 0V$		288	648	μA
I_{IN}	V_{IN} Current In Pulse Skip Mode (No Load)	$V_{IN} = 24V, V_{FCB} = INTVCC, \text{No Load}$		3.5		mA
I_{IN}	V_{IN} Current In Forced Continuous Mode (No Load)	$V_{IN} = 24V, V_{FCB} = 0V, \text{No Load}$		26		mA
Efficiency	Efficiency	$V_{IN} = 24V, I_{OUT} = 6A$		96.4		%

OPERATING PRINCIPLES

The LTC3810 is a synchronous step-down switching regulator controller that can directly step down voltages from up to 100V input, making it ideal for telecom and automotive applications.

The LTC3810 uses a constant on-time valley current control architecture to deliver very low duty

cycles with accurate cycle-by-cycle current limit without requiring a current sense resistor. The current limit is adjustable and the operating frequency is selected by an external resistor.

The LTC3810 has a precise (0.5%) internal reference, a 25MHz error amplifier, large gate drivers,

LTC3810

programmable softstart, a shutdown pin, a Sync input and a Power Good output.

The LTC3810 has a flexible bias regulator circuit that can be configured in many different ways to fit the application. The 10V bias regulator can control an external series transistor that allows the bias voltage to be generated from the input voltage. The demo board provides different footprints for this external series transistor.

An internal low dropout regulator can be used to provide the bias voltage if a 6.7V...15V voltage source is available. For example, in Demonstration Circuit 952 the bias voltage is generated from the input voltage during startup and from the output voltage during normal operation.

The demonstration circuit can be configured to use current sense resistor by moving a couple of zero ohm resistors to different locations.

EQUIPMENT

- 4 DMMs
- 1 DC Supply 0-80V capable of delivering at least 85W
- 1 Adjustable load 0-6A

QUICK START PROCEDURE

Demonstration circuit 952 is easy to set up to evaluate the performance of the LTC3810. Refer to Figure 1 for proper measurement equipment setup and follow the procedure below:

1. Place jumpers in the following positions:
 - JP1** Forced continuous mode operation
 - JP2** ON
2. With power off, connect the input power supply to Vin and GND.
3. Set the power supply to 24V and turn on the power at the input.
 - NOTE.** Make sure that the input voltage does not exceed 80V.
4. Check for the proper output voltage. $V_{out} = 11.8V$ to $12.2V$.
 - NOTE.** If there is no output, temporarily disconnect the load to make sure that the load is not set too high.
5. Once the proper output voltages are established, adjust input voltage and load within the operating range and observe the output voltage regulation, ripple voltage, efficiency and other parameters.

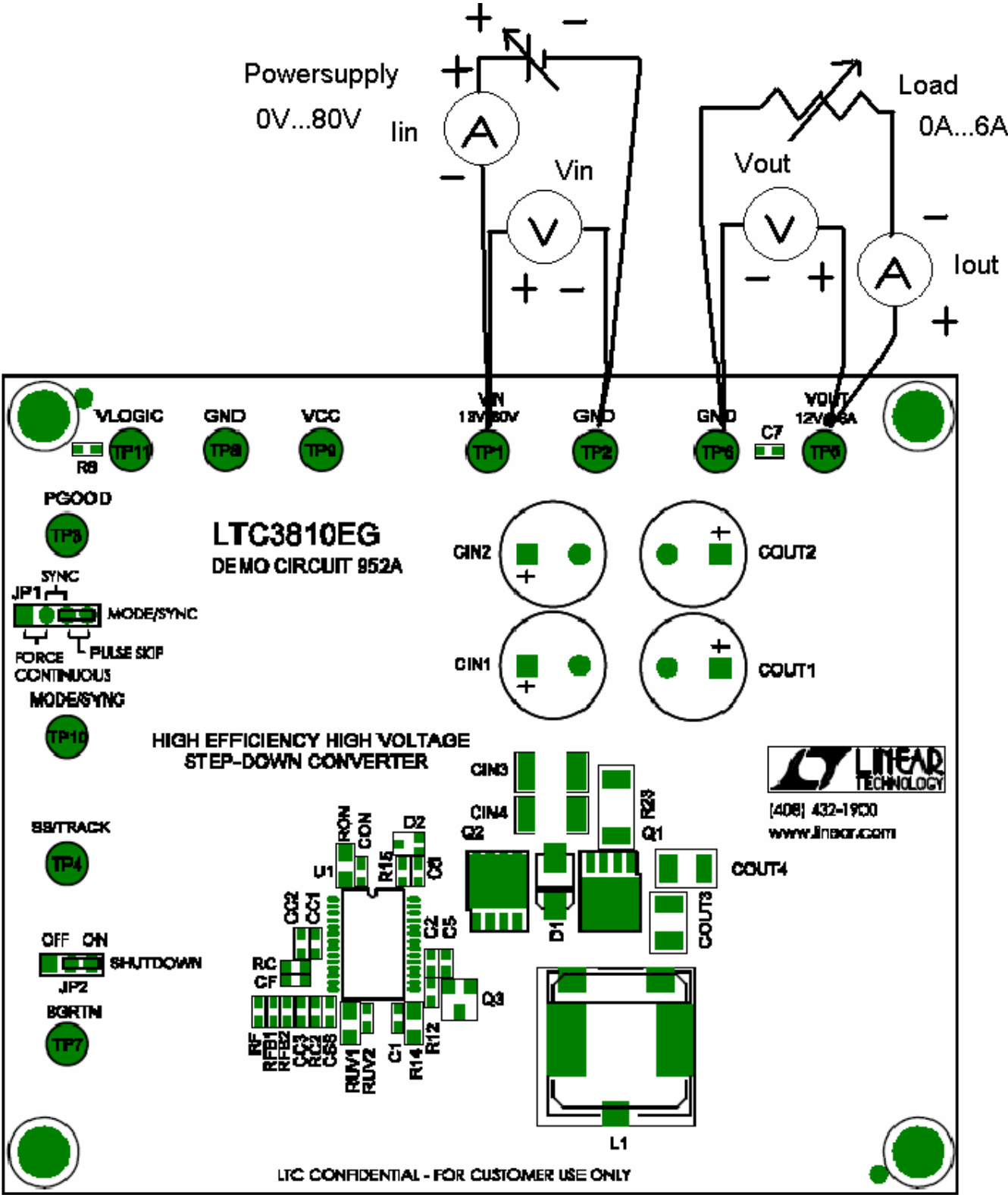
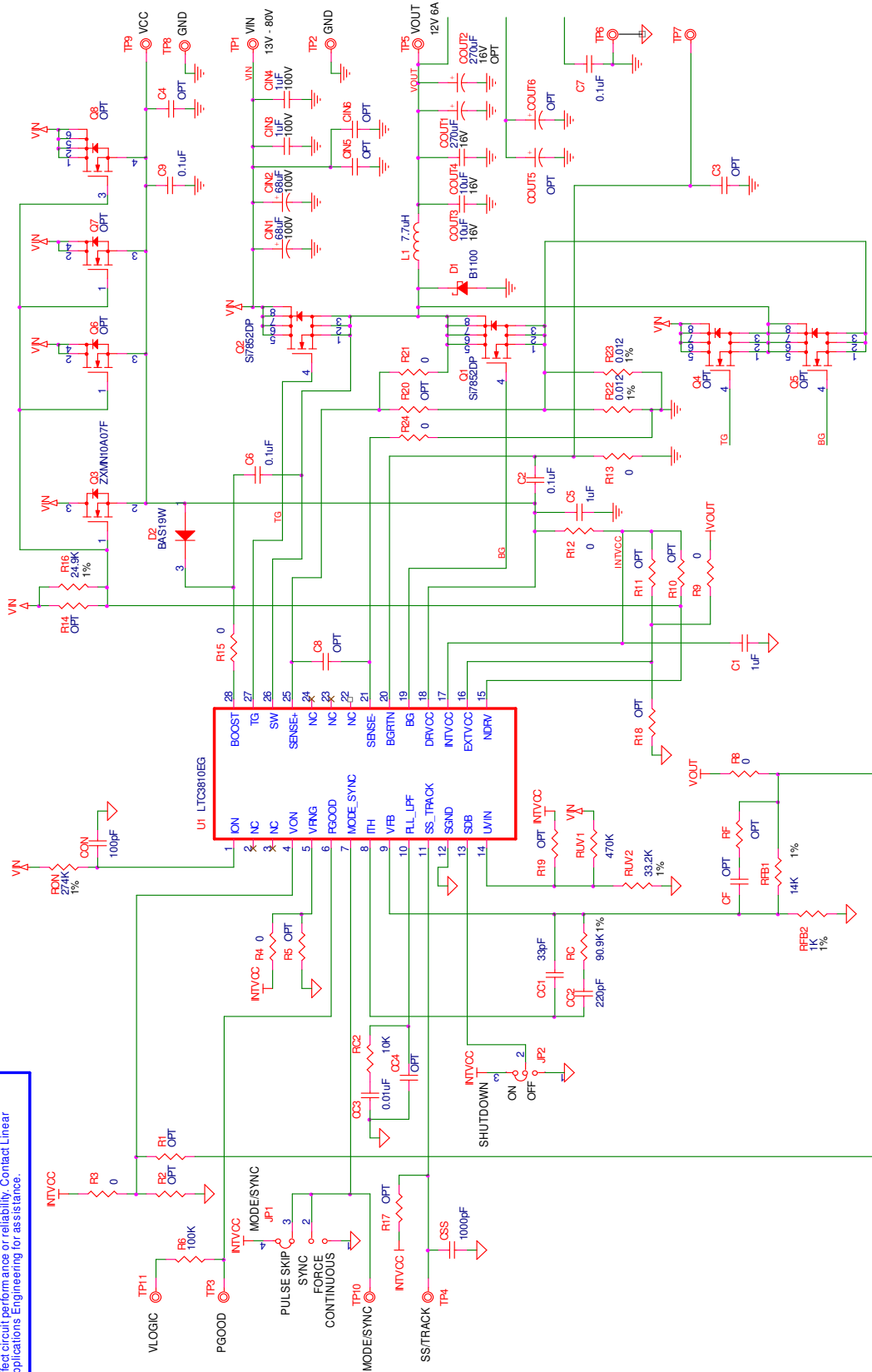

Figure 1. Proper Measurement Equipment Setup

REVISION HISTORY				
ECO	REV	DESCRIPTION	DATE	APPROVED
	4	PROD	10/18/07	

This circuit is proprietary to Linear Technology and supplied for use with Linear Technology parts.
Customer Notice: Linear Technology has made a best effort to ensure the accuracy of this circuit diagram. However, it remains the customer's responsibility to verify proper and reliable operation in the actual application. Component substitution and printed circuit board layout may significantly affect circuit performance or reliability. Contact Linear Applications Engineering for assistance.



CONTRACT NO.		DATE	
APPROVALS		DATE	
DRAWN MI		06/22/05	
CHECKED			
APPROVED			
ENGINEER			
DESIGNER			
TITLE		SCH, LTC3810EG, HIGH EFFICIENCY HIGH VOLTAGE STEP-DOWN CONVERTER	
SIZE		CAGE CODE	
DWG NO		DC952A	
SCALE: NONE		FILENAME: 952A-4.DSN	
SHEET		1 OF 1	



3500 McCarty Blvd.
 Newark, NJ 07102
 Phone: (908) 433-3900
 Fax: (908) 434-0077