

DESIGNED AND DIMENSIONED IN MILLIMETERS[INCHES]
ALL DIMENSIONS REFERENCE EXCEPT AS SHOWN

DO NOT SCALE FROM THIS PRINT

THIS PRODUCT MANUFACTURED WITH LEAD-FREE PROCESSING

BE40A-X-XXXX-X-X-XX-XXXX

TRANSMISSION TYPE

- S: STRIPLINE
- M: MICROSTRIP

END 2 CONNECTOR
(SEE TABLE 1, SHT 3)

PHASE MATCHING SPEC. (RANGE)

- 2: 2 PICO-SECONDS
- 5: 5 PICO-SECONDS
- N: NO PHASE MATCHING

OVERALL ASSEMBLY LENGTH (OAL)
XXXX (MILLIMETERS)
(0152 MIN)
(SEE NOTE 8)

NO OF POSITION (PER ROW)
-03, -04, -06, -08, -10, -12, -14, -16
(SEE TABLE 3, SHT 3)

NO OF ROWS
-2

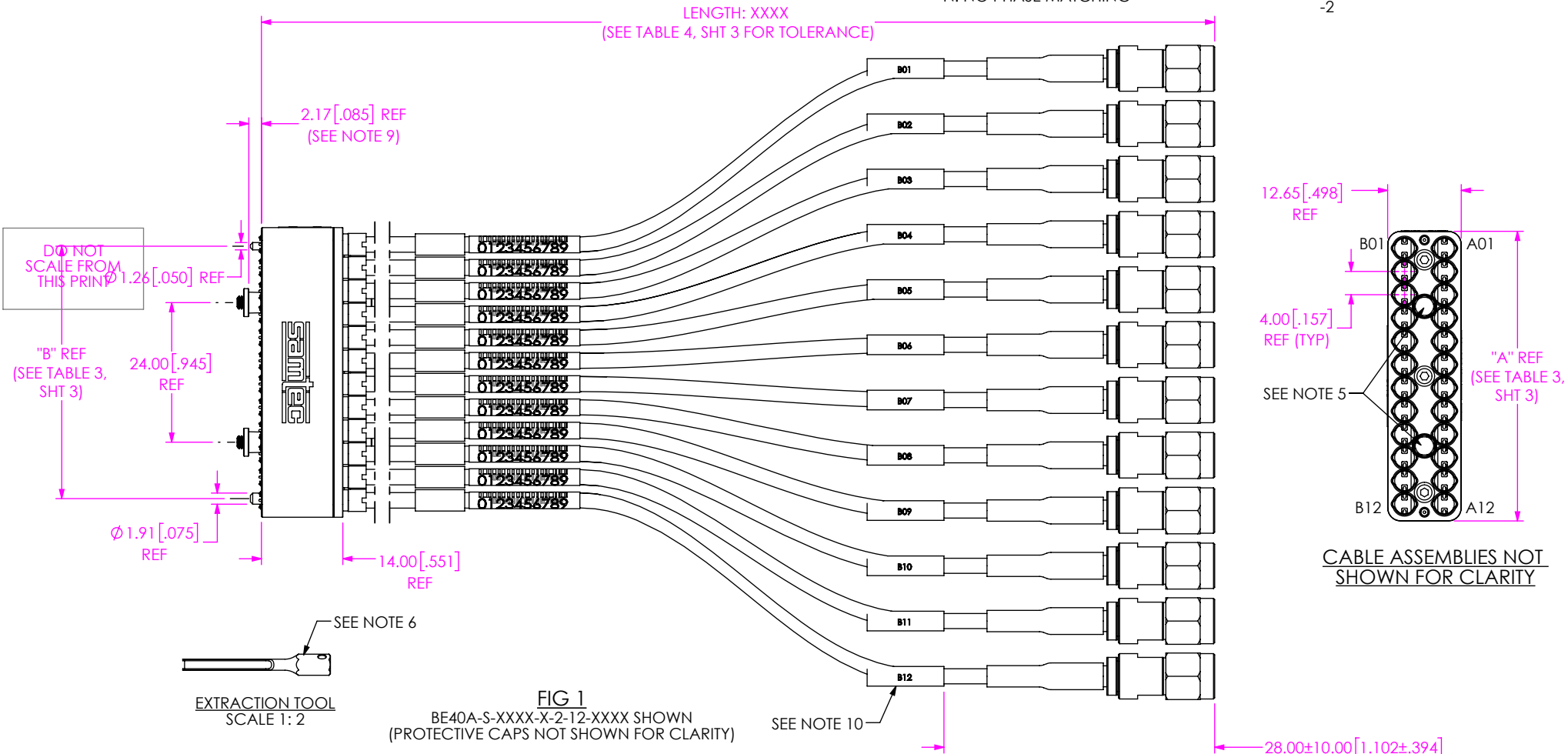

- NOTES:
1. DELETED.
 2. DELETED.
 3. FERRULE AND SPRING ARE FREE FLOATING AND ARE NOT STATIONARY.
 4. ASSEMBLY TO HAVE END 1 WRAPPED IN ANTI-STATIC BUBBLE WRAP AND END 2 ASSEMBLED WITH PROTECTIVE CAPS.
 5. WHEN MOUNTED TO PCB, TIGHTEN PCB SCREW TO 2.0-2.5 IN-LBS USING 3MM HEX TOOL (NOT PROVIDED).
 6. EXTRACTION TOOL TO BE PACKAGED IN ESD BAG (BAG-SS-04X06-Z) AND INCLUDED WITH ASSEMBLY.
 7. MAXIMUM RETURN LOSS: -13.97DB, DC TO 40GHZ.
 8. CABLE LENGTHS LONGER THAN 1000 MILLIMETERS ARE NOT SUPPORTED BY S.I. TEST DATA.
 9. RECOMMEND PCB THICKNESS: .06 INCH - .16 INCH (SEE SHEET 4).
 10. PRINT CABLE POSITION ON WHITE HEAT SHRINK AND APPLY TO CABLES AS SHOWN.

<p>PROPRIETARY NOTE</p> <p>THIS DOCUMENT CONTAINS CONFIDENTIAL AND PROPRIETARY INFORMATION AND ALL DESIGN, MANUFACTURING, REPRODUCTION, USE, PATENT RIGHTS AND SALES RIGHTS ARE EXPRESSLY RESERVED BY SAMTEC, INC. THIS DOCUMENT SHALL NOT BE DISCLOSED, IN WHOLE OR PART, TO ANY UNAUTHORIZED PERSON OR ENTITY NOR REPRODUCED, TRANSFERRED OR INCORPORATED IN ANY OTHER PROJECT IN ANY MANNER WITHOUT THE EXPRESS WRITTEN CONSENT OF SAMTEC, INC.</p>	<p>DESCRIPTION:</p> <p>40GHz Bulls Eye® GANGED ASSEMBLY</p>		
	<p>DO NOT SCALE DRAWING SHEET SCALE: 1:1</p> <p>MATERIAL: HOUSING, COVER, SCREWS, NUTS, SHELL, RETAINER, FERRULE, PIN, BODY: BRASS ALIGNMENT PINS, SCREWS, SHELLS, CABLE BODY, C-RING, NUT INSERT: STAINLESS STEEL</p>	<p>DWG. NO.</p> <p>BE40A-X-XXXX-X-X-XX-XXXX</p>	
<p>F:\DWG\MISC\WKTG\BE40A-X-XXXX-X-X-XX-XXXX-MKT.SLDDRW</p>		<p>BY: PETER D 3/16/2017 SHEET 1 OF 5</p>	

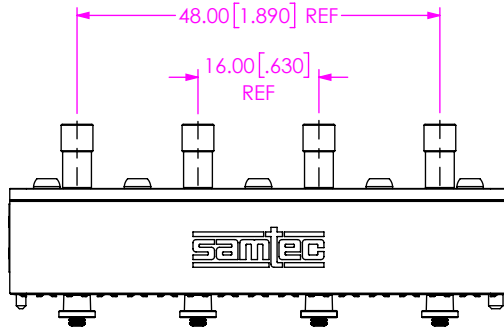

FIG 2
BE40A-S-XXXX-X-2-16-XXXX SHOWN
CABLE ASSEMBLIES NOT SHOWN FOR CLARITY

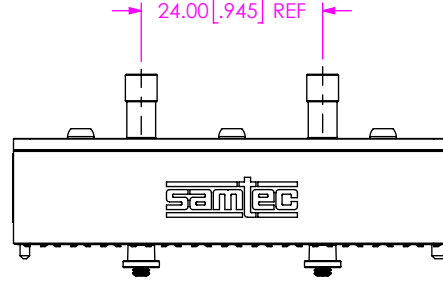

FIG 3
BE40A-S-XXXX-X-2-14-XXXX SHOWN
CABLE ASSEMBLIES NOT SHOWN FOR CLARITY

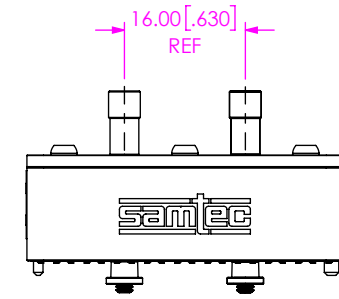

FIG 4
BE40A-S-XXXX-X-2-10-XXXX SHOWN
CABLE ASSEMBLIES NOT SHOWN FOR CLARITY

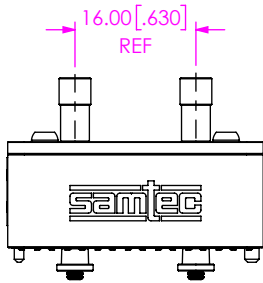

FIG 5
BE40A-S-XXXX-X-2-08-XXXX SHOWN
CABLE ASSEMBLIES NOT SHOWN FOR CLARITY

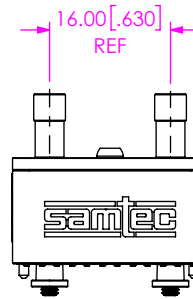

FIG 6
BE40A-S-XXXX-X-2-06-XXXX SHOWN
CABLE ASSEMBLIES NOT SHOWN FOR CLARITY

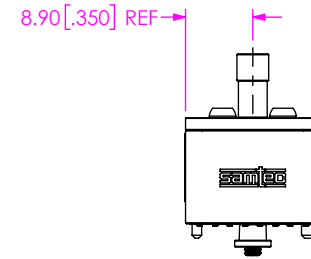

FIG 7
BE40A-S-XXXX-X-2-04-XXXX SHOWN
CABLE ASSEMBLIES NOT SHOWN FOR CLARITY

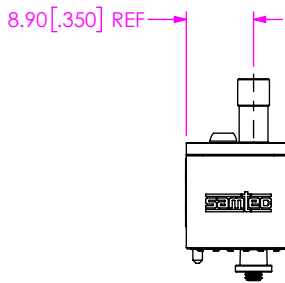

FIG 8
BE40A-S-XXXX-X-2-03-XXXX SHOWN
CABLE ASSEMBLIES NOT SHOWN FOR CLARITY

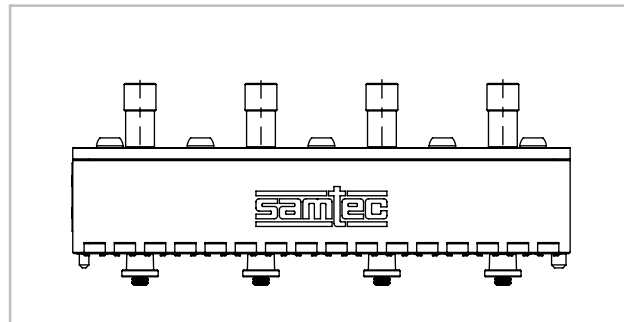

FIG 13
BE40A-M-XXXX-X-2-16-XXXX SHOWN
(DIFFERENT AS SHOWN, OTHERWISE SAME AS FIG 2)
CABLE ASSEMBLIES NOT SHOWN FOR CLARITY

F:\DWG\MISC\MKTG\BE40A-X-XXXX-X-X-XXXX-MKT.SLDDRW

PROPRIETARY NOTE
THIS DOCUMENT CONTAINS CONFIDENTIAL AND PROPRIETARY INFORMATION AND ALL DESIGN, MANUFACTURING, REPRODUCTION, USE, PATENT RIGHTS AND SALES RIGHTS ARE EXPRESSLY RESERVED BY SAMTEC, INC. THIS DOCUMENT SHALL NOT BE DISCLOSED, IN WHOLE OR PART, TO ANY UNAUTHORIZED PERSON OR ENTITY NOR REPRODUCED, TRANSFERRED OR INCORPORATED IN ANY OTHER PROJECT IN ANY MANNER WITHOUT THE EXPRESS WRITTEN CONSENT OF SAMTEC, INC.

DO NOT SCALE DRAWING

SHEET SCALE: 1:1



520 PARK EAST BLVD, NEW ALBANY, IN 47150
PHONE: 812-944-6733 FAX: 812-948-5047
e-Mail info@SAMTEC.com code 55322

DESCRIPTION: 40GHz Bulls Eye® GANGED ASSEMBLY

DWG. NO. BE40A-X-XXXX-X-X-XX-XXXX

BY: PETER D 3/16/2017 SHEET 2 OF 5

TABLE 1							
END OPTION	SERIES	GENDER	CONFIGURATION	PLATING			FIGURE
				CENTER CONTACT	GROUND CONTACTS	CABLE BODY	
-92SP	2.92 MM	PLUG	STRAIGHT	30μ" GOLD	STAINLESS STEEL	2μ" GOLD	SHT 4, FIG 9
-92SJ	2.92 MM	JACK	STRAIGHT	30μ" GOLD	STAINLESS STEEL	2μ" GOLD	SHT 4, FIG 10
-24SP	2.4 MM	PLUG	STRAIGHT	30μ" GOLD	STAINLESS STEEL	2μ" GOLD	SHT 5, FIG 11
-24SJ	2.4 MM	JACK	STRAIGHT	30μ" GOLD	STAINLESS STEEL	2μ" GOLD	SHT 5, FIG 12

TABLE 2 - PHASE MATCHED PAIRS		
PAIR NO.	POSITION	POSITION
1	A01	B01
2	A02	B02
3	A03	B03
4	A04	B04
5	A05	B05
6	A06	B06
7	A07	B07
8	A08	B08
9	A09	B09
10	A10	B10
11	A11	B11
12	A12	B12
13	A13	B13
14	A14	B14
15	A15	B15
16	A16	B16

CAUTION: EACH PAIR OF CABLES TO BE PHASE MATCHED PER CALLOUT. IF RE-WORKED, THE ENTIRE PAIR MUST BE REPLACED.

TABLE 3		
No OF POSITIONS	"A"	"B"
-03	13.80 [0.543]	N/A
-04	17.80 [0.701]	14.80 [0.583]
-06	25.80 [1.016]	22.80 [0.898]
-08	33.80 [1.331]	30.80 [1.213]
-10	41.80 [1.646]	38.80 [1.528]
-12	49.80 [1.961]	43.40 [1.709]
-14	57.80 [2.276]	54.80 [2.157]
-16	65.80 [2.591]	62.80 [2.472]

TABLE 4: FINAL ASSEMBLY LENGTH TOLERANCE	
LENGTH	TOLERANCE
0152-0200 [5.98-7.87]	+3.0 [.12]/-0.0 [.00]
0200-0500 [7.87-19.69]	+5.0 [.20]/-0.0 [.00]
0500-9999 [19.69-43.30]	+10.0 [.40]/-0.0 [.00]

PROPRIETARY NOTE
 THIS DOCUMENT CONTAINS CONFIDENTIAL AND PROPRIETARY INFORMATION AND ALL DESIGN, MANUFACTURING, REPRODUCTION, USE, PATENT RIGHTS AND SALES RIGHTS ARE EXPRESSLY RESERVED BY SAMTEC, INC. THIS DOCUMENT SHALL NOT BE DISCLOSED, IN WHOLE OR PART, TO ANY UNAUTHORIZED PERSON OR ENTITY NOR REPRODUCED, TRANSFERRED OR INCORPORATED IN ANY OTHER PROJECT IN ANY MANNER WITHOUT THE EXPRESS WRITTEN CONSENT OF SAMTEC, INC.

DO NOT SCALE DRAWING

SHEET SCALE: 1:1



520 PARK EAST BLVD, NEW ALBANY, IN 47150
 PHONE: 812-944-6733 FAX: 812-948-5047
 e-Mail info@SAMTEC.com code 55322

DESCRIPTION:
 40GHz Bulls Eye® GANGED ASSEMBLY

DWG. NO.
BE40A-X-XXXX-X-X-XX-XXXX

BY: PETER D 3/16/2017 SHEET 3 OF 5

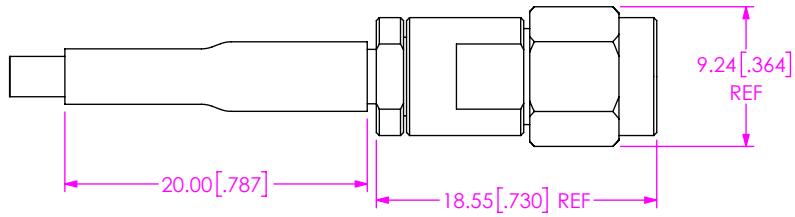

FIG 9
-92SP SHOWN

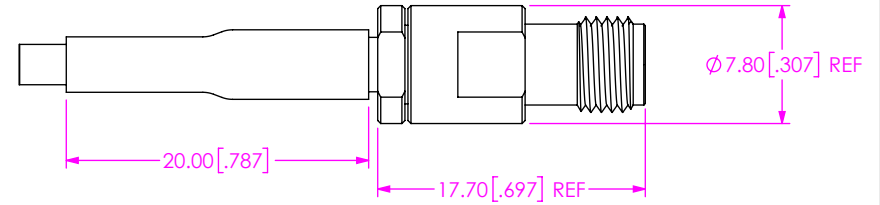
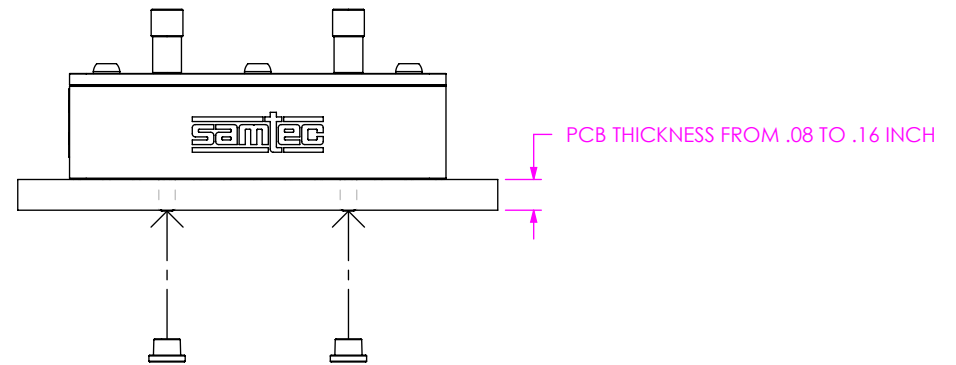
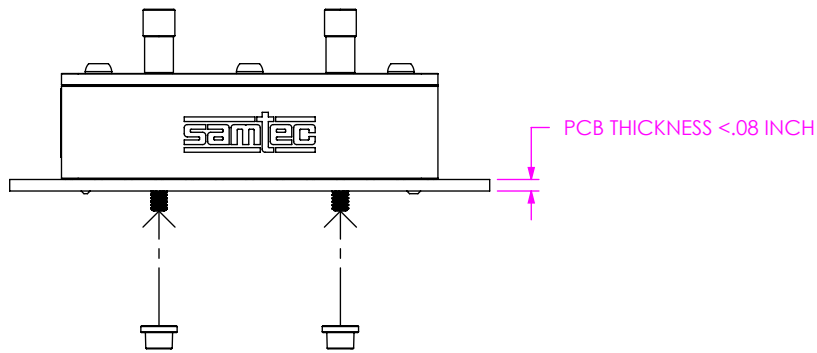

FIG 10
-92SJ SHOWN



DIRECTION OF PCB NUTS

PROPRIETARY NOTE
 * THIS DOCUMENT CONTAINS CONFIDENTIAL AND PROPRIETARY INFORMATION AND ALL DESIGN, MANUFACTURING, REPRODUCTION, USE, PATENT RIGHTS AND SALES RIGHTS ARE EXPRESSLY RESERVED BY SAMTEC, INC. THIS DOCUMENT SHALL NOT BE DISCLOSED, IN WHOLE OR PART, TO ANY UNAUTHORIZED PERSON OR ENTITY NOR REPRODUCED, TRANSFERRED OR INCORPORATED IN ANY OTHER PROJECT IN ANY MANNER WITHOUT THE EXPRESS WRITTEN CONSENT OF SAMTEC, INC.

DO NOT SCALE DRAWING

SHEET SCALE: 2:1

samtec

520 PARK EAST BLVD, NEW ALBANY, IN 47150
 PHONE: 812-944-6733 FAX: 812-948-5047
 e-Mail info@SAMTEC.com code 55322

DESCRIPTION: 40GHz Bulls Eye® GANGED ASSEMBLY

DWG. NO. BE40A-X-XXXX-X-X-XX-XXXX

BY: PETER D 3/16/2017 SHEET 4 OF 5

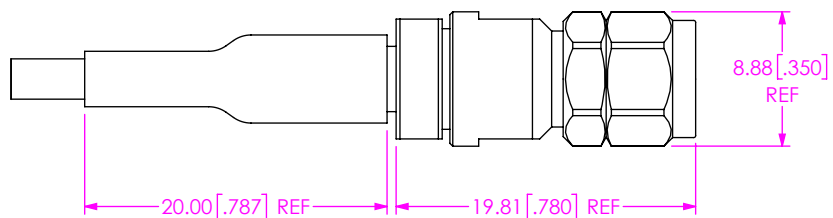

FIG 11
-24SP SHOWN

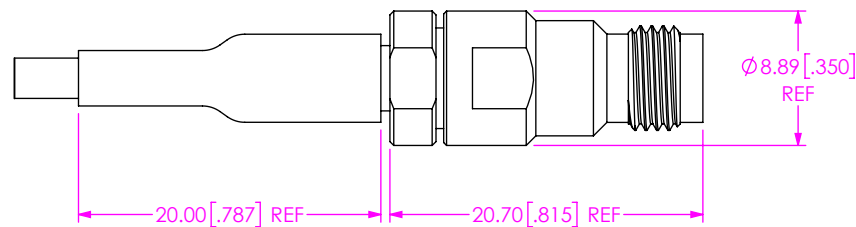

FIG 12
-24SJ SHOWN

PROPRIETARY NOTE
 * THIS DOCUMENT CONTAINS CONFIDENTIAL AND PROPRIETARY INFORMATION AND ALL DESIGN, MANUFACTURING, REPRODUCTION, USE, PATENT RIGHTS AND SALES RIGHTS ARE EXPRESSLY RESERVED BY SAMTEC, INC. THIS DOCUMENT SHALL NOT BE DISCLOSED, IN WHOLE OR PART, TO ANY UNAUTHORIZED PERSON OR ENTITY NOR REPRODUCED, TRANSFERRED OR INCORPORATED IN ANY OTHER PROJECT IN ANY MANNER WITHOUT THE EXPRESS WRITTEN CONSENT OF SAMTEC, INC. *

DO NOT SCALE DRAWING

SHEET SCALE: 2:1



520 PARK EAST BLVD, NEW ALBANY, IN 47150
 PHONE: 812-944-6733 FAX: 812-948-5047
 e-Mail info@SAMTEC.com code 55322

DESCRIPTION: 40GHz Bulls Eye GANGED ASSEMBLY

DWG. NO. BE40A-X-XXXX-X-X-XX-XXXX

BY: PETER D 3/16/2017 SHEET 5 OF 5