

REVISIONS			
REV	DESCRIPTION, ECN, EAR NO.	DATE	APP'D
A	PROPOSAL	JUL07/20	L.CHAN

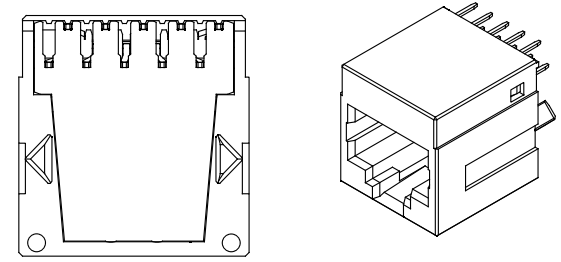
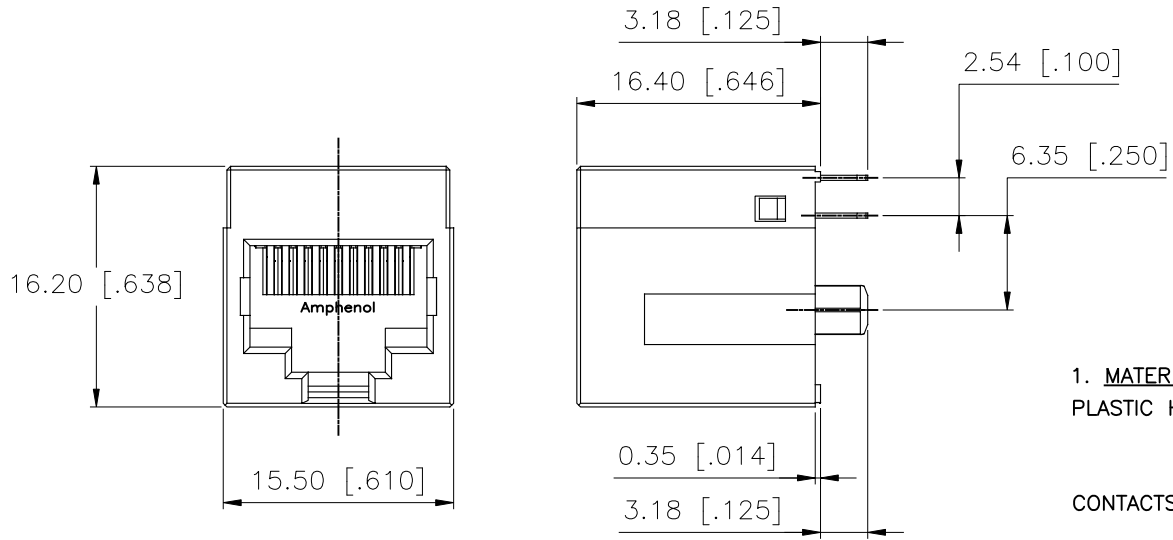

1. MATERIALS:
 PLASTIC HOUSING: THERMOPLASTIC PER MATERIAL OPTION IN PART NO.
 FLAMMABILITY RATING UL 94V-0
 COLOUR: BLACK

CONTACTS: PHOSPHOR BRONZE
 PLATING: REFER TO PART NO. FOR GOLD THICKNESS ON MATING SURFACES.
 50 μ " [1.27 MICRONS]
 MIN. NICKEL UNDERPLATE
 100 μ " [2.54 MICRONS]
 MIN. MATTE TIN ON CONTACT TAILS.

OPERATING TEMPERATURE: -55°C TO +105°C
 AMPHENOL PART NUMBER: RJE74-1AA-0X11-X

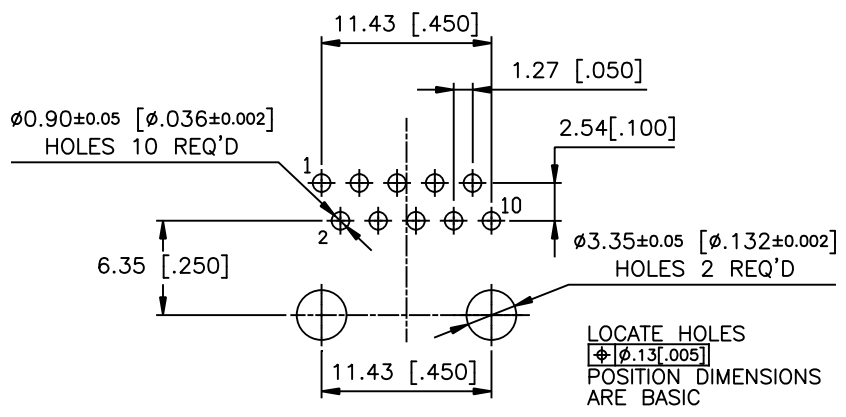

RECOMMENDED P.C.B LAYOUT
 (COMPONENT SIDE OF BOARD
 TOLERANCES: +/- 0.05[.002],
 BASED ON PRODUCT WITH SHIELD)

BLANK= PBT, TRAY PACKAGING,
 W/O MYLAR
 A= HIGH TEMP. MATERIAL,
 TRAY PACKAGING, W/O MYLAR
 H= HIGH TEMP. MATERIAL
 TAPE/REEL PACKAGING, WITH MYLAR

GOLD PLATING
 1 = 6 μ " 3 = 30 μ "
 2 = 15 μ " 4 = 50 μ "



UNLESS SPECIFIED OTHERWISE	DRAWN STEVE.X	JUL07/20	Amphenol Canada Corp. www.amphenolcanada.com
PRIMARY UNITS MILLIMETERS	CHECKED		
SECONDARY INCHES	M.E. APP'D		MODULAR JACK, 10 POSITION & 10 CONTACT, UNSHIELDED, WITH KEYING FEATURE, TRAY PACKAGING, - RoHS COMPLIANT
REFERENCE IN PARENTHESES	Q.A. APP'D		
GENERAL TOLERANCES	DWG APP'D L.CHEN	JUL07/20	DWG NO. P-RJE74-1AA-0X11-X
1 DECIMAL PLACE ±0.38	ENG. REL. NO.		
2 DECIMAL PLACES ±0.25	REF.		REV A
3 DECIMAL PLACES			
ANGULAR DEGREES ±1.5°	THIRD ANGLE PROJECTION	DO NOT SCALE DRAWING	CODE ID NO. 03554 DWG SIZE: C SCALE: N/A SHEET 1 OF 2

REVISIONS			
REV	DESCRIPTION, ECN, EAR NO.	DATE	APP'D
A	PROPOSAL	JUL07/20	L.CHAN

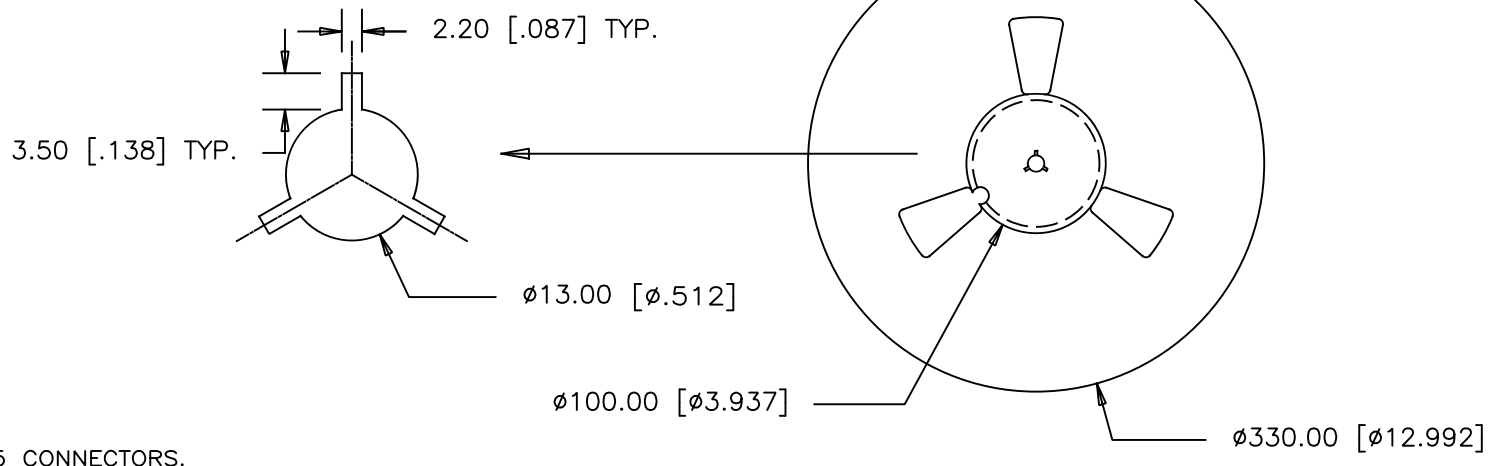
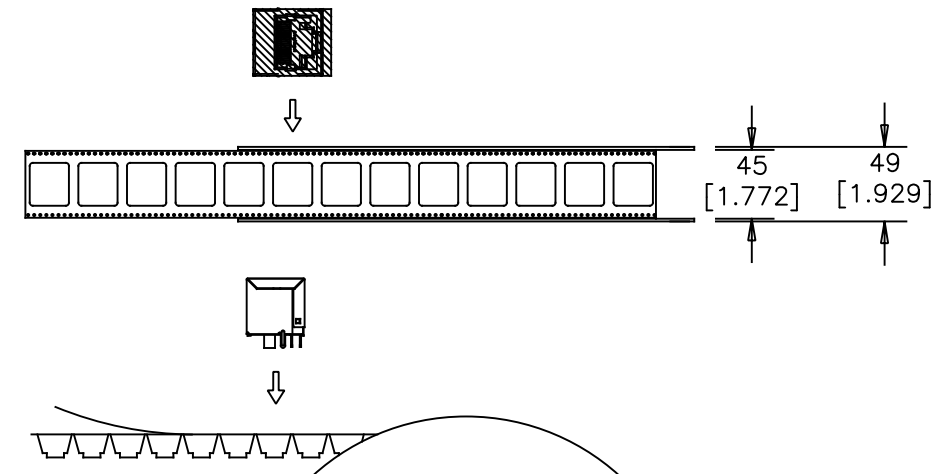
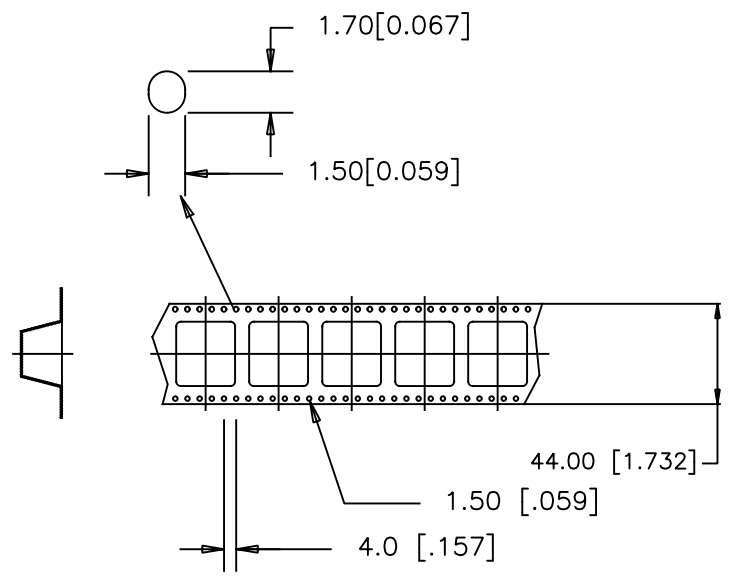

PACKAGING NOTES:

1. ONE REEL SHOULD HOLD 85 CONNECTORS.
2. 10 EMPTY CAVITIES FOR BOTH TOP AND BOTTOM OF THE CARRIER.
3. A FULLY LOADED CARTON SHOULD CONTAIN 5 REELS (425 PCS) OF CONNECTOR.

UNLESS SPECIFIED OTHERWISE PRIMARY UNITS MILLIMETERS SECONDARY INCHES REFERENCE IN PARENTHESES	DRAWN STEVE.X CHECKED M.E. APP'D Q.A. APP'D DWG APP'D L.CHEN ENG. REL. NO. REF.	JUL07/20 JUL07/20	Amphenol Canada Corp. www.amphenolcanada.com
MODULAR JACK, 10 POSITION & 10 CONTACT, UNSHIELDED, WITH KEYING FEATURE, TRAY PACKAGING, - RoHS COMPLIANT			DWG NO. P-RJE74-1AA-0X11-X
THIRD ANGLE PROJECTION DO NOT SCALE DRAWING			REV A
THIS DOCUMENT CONTAINS PROPRIETARY INFORMATION AND SUCH INFORMATION MAY NOT BE DISCLOSED TO OTHERS FOR ANY PURPOSE OR USED FOR MANUFACTURING PURPOSES WITHOUT WRITTEN PERMISSION FROM AMPHENOL CANADA CORP.			CODE ID NO. 03554 DWG SIZE: C SCALE: N/A SHEET 2 OF 2