

APPROVAL SHEET

Model No. : UB1465

Only No. : _____

Date : _____

APPROVER	CHECKER	DESIGN

Please kindly make approval of our samples, And return this form by fax or airmail,
Thanks for your kind attention and co-operation.

Customer Name: _____

Customer Model No: _____

Project Reference: _____

CUSTOMER APPROVAL

NAC HOLDINGS LIMITED.

Tel: 86-755-23341456 Fax: 86-755-23324431

Http://www.nacoustics.com sales@nacoustics.com

1. Electrical Characteristics

1.1 Temp.=20±2°C

Room Humidity=65±5%

PARAMETER	SYMBOL	CONDITION	LIMITS			UNIT
			Min	Center	Max	
Sensitivity	S	F=1KHZ,S.P.L=1Pa 0dB=1V/Pa	-48	-45	-42	dB
Output impedance	Zout	F=1KHZ			2.2	kΩ
Current Consumption	IDss	VS=2.0V RL=2.2KΩ			500	μA
Directivity	Unidirectional					
Signal to Noise Ratio	S/N	S:(F=1KHz,S.P.L=1Pa) a) N:(A-Weighted curve)	60			dB
Decreasing Voltage	ΔS-VS	Vs=1.5V to1.0V			-3	dB
Sensitivity Δ0°~180°		F=1KHz,S.P.L=1Pa	15			dB
Operating voltage			1.0		10	V
Maximum input S.P.L		F=1KHz,THD<1%	120			dB

(Reminding: In order to calibrate the sensitivity of ECMs accordingly, we use the unit “Pascal” instead of “μbar”, when using the unit “Pascal”,20dB will be increased comparatively ,for example:-60 dB (0 dB = 1 V / μbar) = -40 dB (0 dB = 1 V / Pa))

1.2 Frequency Response

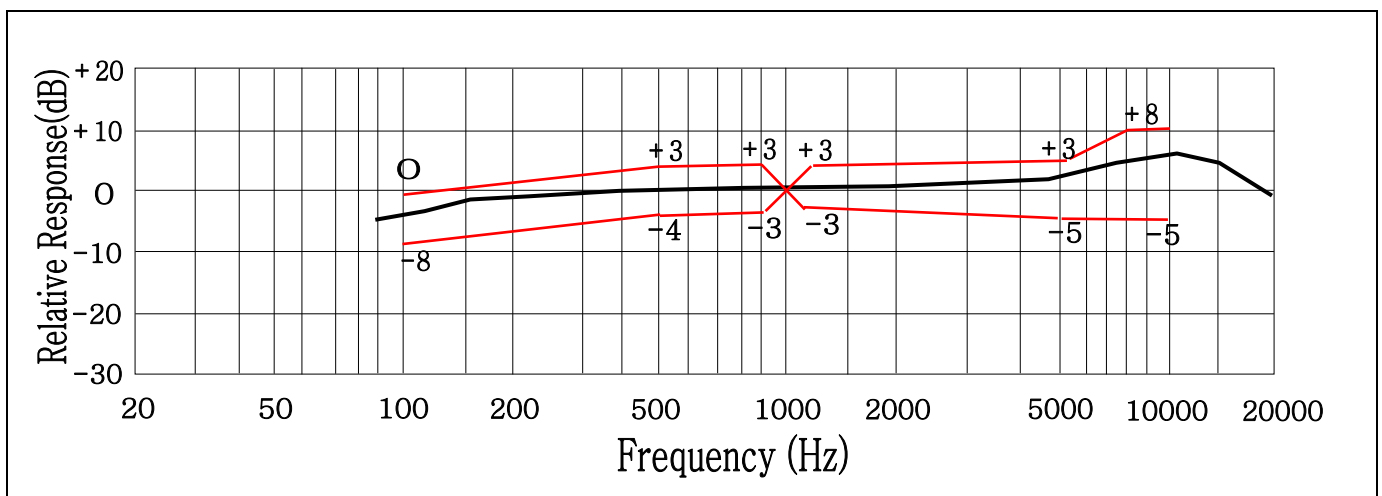

1.3 Polar Plots

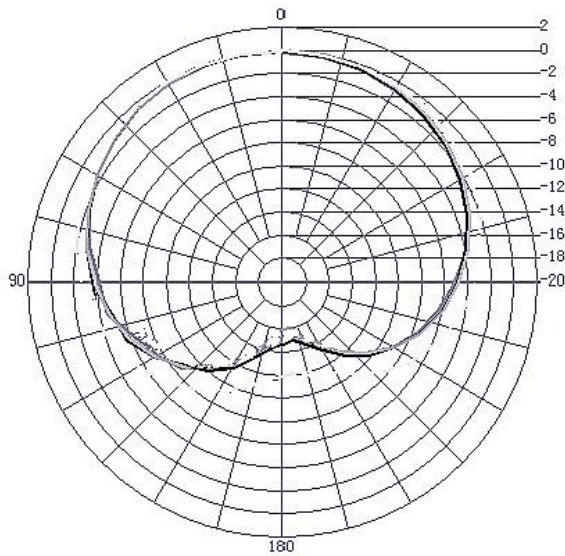

At 1KHz

2. Measurement Circuit

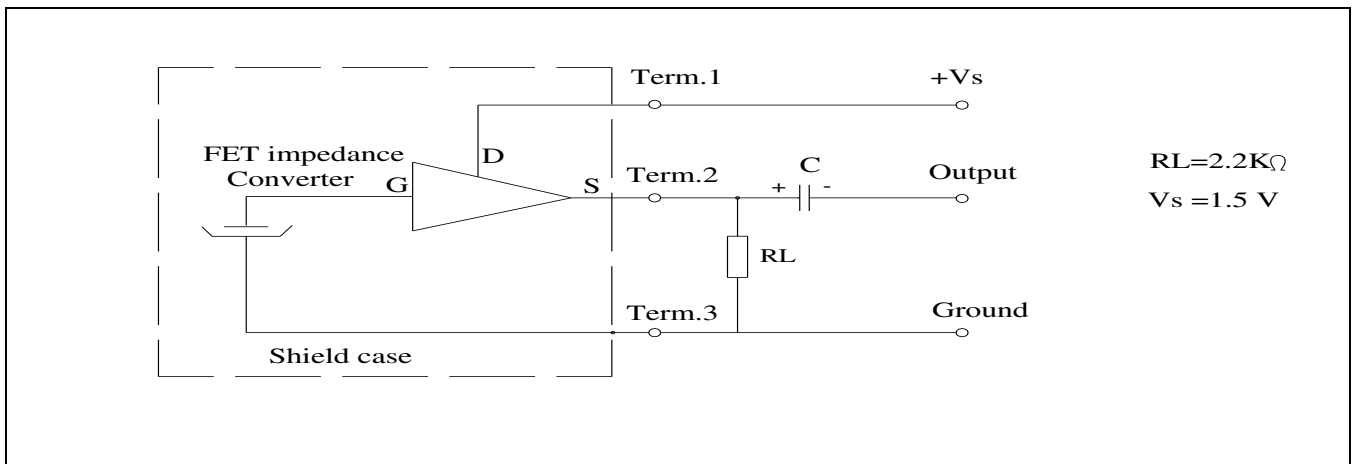

3. Mechanical Characteristics

Soldering Heat Shock	To be no interference in operation after soldering Heat shock, temperature $320^{\circ}\text{C} \pm 20^{\circ}\text{C}$ for 2 ± 1 seconds
Terminal Mechanical Strength	To be no interference in operation after pulled the terminal with 0.5 kg strength for 3 seconds.

4. Appearance & Dimensions

Unit: mm

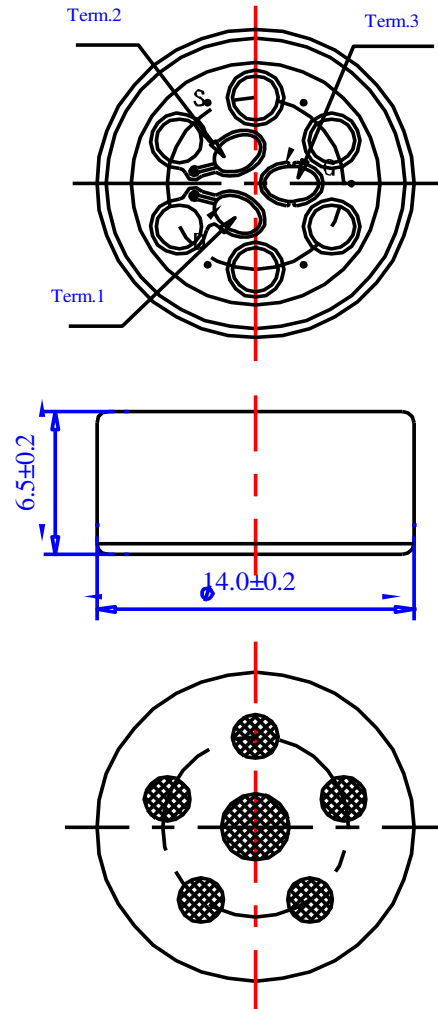

REMARK:

1. N Acoustics may upgrade the component layout, color, parameters without notice
2. Color difference is a result of different purchase batches, which will not affect function, so it will not be considered as an acceptance criterion.
3. The percentage of assigned sensitivity entering adjacent range is less than 30%.

5. Reliability Test

All tests are to be carried out on the same test batch in the order listed.
The sensitivity should be within ± 3 dB from initial sensitivity after 3 hours recovering on the conditioning of 20°C.

Temperature Test	After exposure at 60°C for 200 hours, the sensitivity should be within ± 3 dB from the initial value.
	After exposure at -25°C for 200 hours, the sensitivity should be within ± 3 dB from the initial value.
Humidity Test	After exposure at 40°C and 90~95% relative humidity for 200 hours, the sensitivity should be within ± 3 dB from the initial value.
Temperature Cycle Test	After exposure at -25°C for 30 minutes, at 20°C for 10 minutes, at 60°C for 30 minutes, at 20°C for 10 minutes, for 5 cycles, the sensitivity should be within ± 3 dB from the initial value.
Vibration Test	To ensure no effect on use after vibrations, 10 Hz to 50 Hz for 1-minute at full amplitude of 1.52 mm, for 2 hours at 3 axes test are carried out.
Drop Test	To ensure no effect on use after being dropped, the test microphone in its packaging is dropped on a concrete floor from a height of 1-meter on 3 faces of the packaging.

6. Standard Testing for Sensitivity

6.1 Requirement:

The tolerance of sensitivity is within ± 3 dB to the reference microphone.

6.2 Test Method:

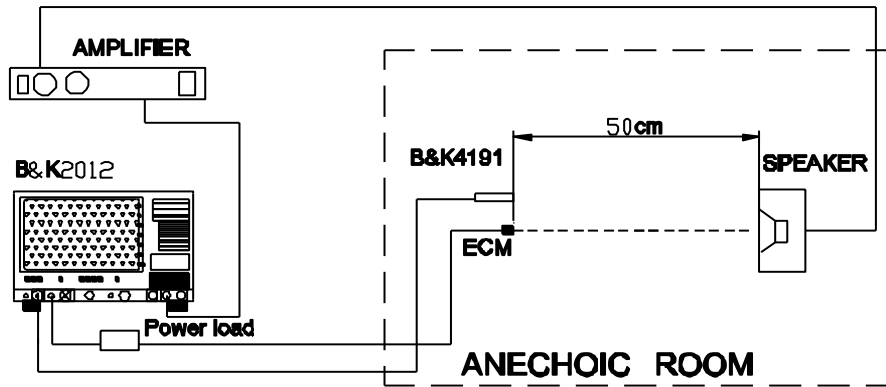

6.2.1 Test the microphone with standard operating condition.

6.2.2 Put the microphone and standard microphone to face the sound output place (speaker), the distance from sound output to microphone & standard microphone is 50cm. And keep the center distance 5cm between each other to ensure the sound pressure change should be keep in ± 1 dB.

6.3.3 Keep the sound source pressure within ± 1 dB from speaker (Measured by the reference microphone).

6.3.4 The sensitivity of microphone can obtain its output voltage when sound source kept within 1000 Hz and 1 Pa.

6.4 Test Condition

In Normal Weather	In Arbitrate Weather
Environment Temperature : 5 ~ 35°C	Environment Temperature: 5 ~ 35°C
Relative Humidity : 45% ~ 85%	Relative Humidity : 60% ~ 70%
Air Pressure : 86 ~ 106KPa	Air Pressure : 86 ~ 106KPa

7. Soldering Operation

As a kind of very sensitive components for temperature and static impacting, MIC is easy influenced by the FET and the vibrant diaphragm, the FET can be destroyed by strong heat and static; The diaphragm can be destroyed by strong heat. If the operation is unsuitable or bad protection during the soldering process, it will affect MIC function and even destruction, So please pay attention to the following request when soldering,

7.1. Solder temperature and time

7.1.1. Suggest Iron of constant temperature;

7.1.2. Suggest lead-free soldering temperature range $320^{\circ}\text{C} \pm 20^{\circ}\text{C}$ (external soldering temperature of Iron needle);

7.1.3. the actual temperature of the user is according to PCB layers and soldering way to adjust soldering temperature.

7.1.4. soldering skill: soldering time of single point is within 2 seconds; Don't continue soldering same mic (please repair soldering once badly after cooling it)

7.1.5. Belongs to normal phenomenon that the sensitivity of the microphone change 0.5dB to 1dB within stipulating soldering temperature and time range.

7.1.6. If soldering temperate of the mic increase and prolong time, Sensitivity will have a big change, and even destroy inner structure, performance.

7.2. Soldering Quality

The soldering point can't leave sand hole or empty hole after soldering. (sand hole or empty hole will affect sensitivity and performance) continuous soldering phenomena.

7.3. Static protecting

electric iron、test machine work stand、soldering tool must effectively connect earth. The operator must wear ring of resisting static.

7.4. Heat scattered defending

7.4.1. Using heat scattered tool, Choose Al or Cooper, Please refer the following drawing

7.4.2. The heat scattered tool of user, whose shape need according to actual the position of soldering product and space to design or increase blow air tool for scattering heat.

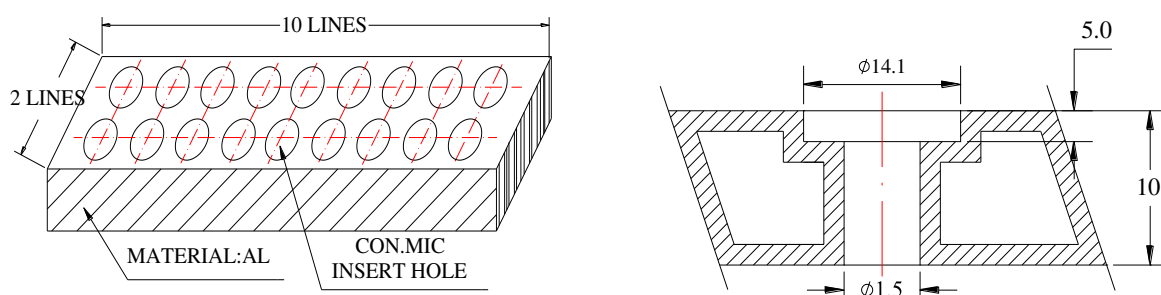

8. Stock and Transportation

8.1 A good package will help Mic. on using normal transportation. Pls pay more attention to prevent humid, shake, sunlight and heavy press.

8.2 The full packed Mic. Should be store at warehouse in $-25 \sim +70^{\circ}\text{C}$, and the relative humidity not bigger than 90%. The warehouse must keep constant temperature, without acid or any other poisonous gas, and not caused any influence from strong magnetic field.

8.3 Storage Temperature Range : $-25^{\circ}\text{C} \sim +70^{\circ}\text{C}$

Operating Temperature Range : $-20^{\circ}\text{C} \sim +60^{\circ}\text{C}$