

Low power single voltage comparator

Features

- Wide single supply voltage range or dual supplies
+2V to +36V or $\pm 1V$ to $\pm 18V$
- Very low supply current: 0.3mA typ. at $V_{CC^+} = 5V$
- Low input bias current: 20nA typ.
- Low input offset current: 0.5nA typ.
- Low input offset voltage: 0.5mV typ.
3mV max.
- Input common-mode voltage range includes ground
- Low output saturation voltage: 80mV typ. ($I_{sink} = 4mA$)
- Differential input voltage range equal to the supply voltage
- TTL, DTL, ECL, MOS, CMOS compatible outputs
- Internal ESD protection
Human body model (HBM) $\pm 2000V$ typ.

Description

The NJM390A/NJM391A are single comparator designed specifically to operate from a single supply over a wide range of voltages. Operation from split power supplies is also possible.

The NJM390A/391A also have a unique characteristic in that the input common-mode voltage range includes ground even though operated from a single power supply voltage.

1 Schematic diagram

Figure 1. Schematic diagram

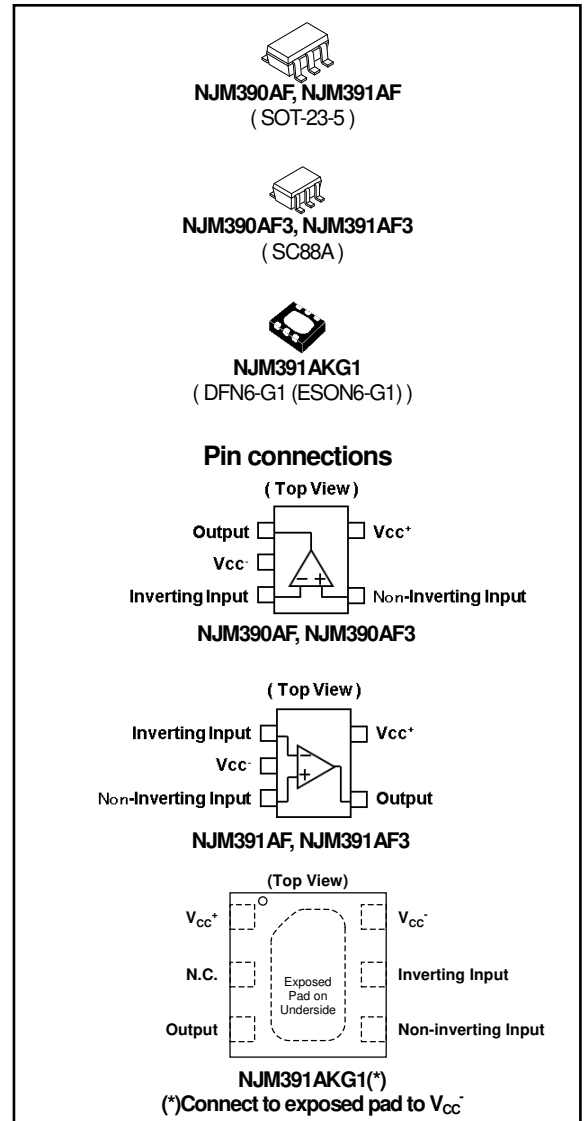
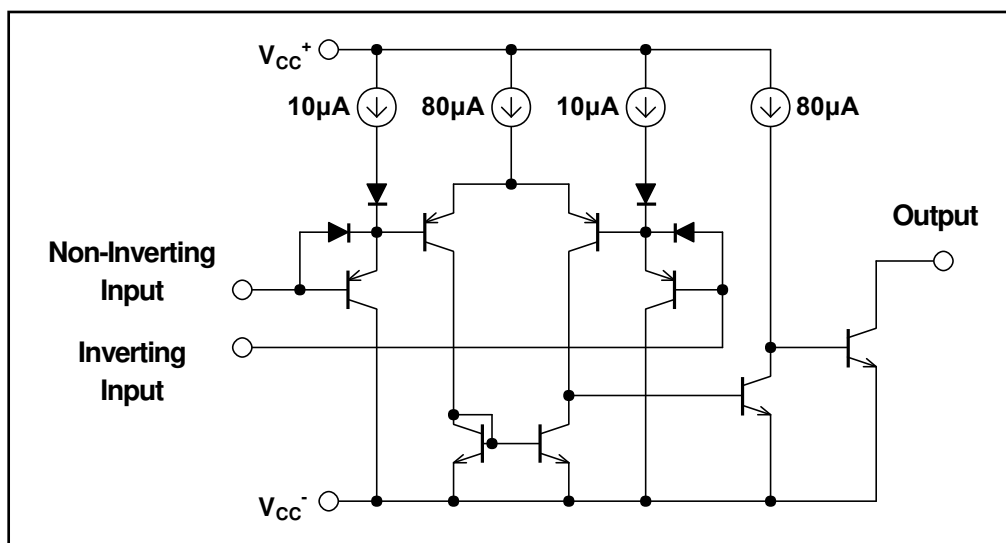

NJM390A/NJM391A

2 Absolute maximum ratings and operating conditions

Table1. Absolute maximum ratings (T_{amb}=25°C)

Symbol	Parameter	Value	Unit
V _{CC}	Supply voltage(V _{CC} ⁺ - V _{CC} ⁻)	36	V
V _{ID}	Differential input voltage	±36	V
V _{IN}	Input voltage ⁽¹⁾	V _{CC} -0.3 to V _{CC} +36	V
V _O	Output Terminal Input Voltage ⁽²⁾	V _{CC} -0.3 to V _{CC} +36	V
-	Output short-circuit to V _{CC} ⁻ ⁽³⁾	Infinite	-
T _{stg}	Storage temperature range	-65 to +150	°C
T _j	Maximum junction temperature	150	°C
P _D	Power Dissipation	SOT-23-5 : 480 ⁽⁵⁾ , 650 ⁽⁶⁾ SC88A : 360 ⁽⁵⁾ , 490 ⁽⁶⁾ DFN6-G1 : 330 ⁽⁷⁾ , 1200 ⁽⁸⁾	mW
θ _{ja}	thermal resistance junction to ambient ⁽⁴⁾	SOT-23-5 : 260 ⁽⁵⁾ , 195 ⁽⁶⁾ SC88A : 355 ⁽⁵⁾ , 260 ⁽⁶⁾ DFN6-G1 : 385 ⁽⁷⁾ , 110 ⁽⁸⁾	°C/W
ψ _{jt}	thermal resistance junction to top surface of IC package ⁽⁴⁾	SOT-23-5 : 68 ⁽⁵⁾ , 58 ⁽⁶⁾ SC88A : 91 ⁽⁵⁾ , 74 ⁽⁶⁾ DFN6-G1 : 65 ⁽⁷⁾ , 26 ⁽⁸⁾	°C/W

1. Input voltage is the voltage should be allowed to apply to the input terminal independent of the magnitude of V_{CC}⁺.
 2. Output voltage is the voltage should be allowed to apply to the output terminal independent of the magnitude of V_{CC}⁺.
 3. Short-circuits from the output to V_{CC}⁺ can cause excessive heating and potential destruction.
 4. Short-circuit can cause excessive heating and destructive dissipation. Values are typical.
 5. EIA/JEDEC STANDARD Test board (76.2 x 114.3 x 1.6mm, 2layers, FR-4) mounting
 6. EIA/JEDEC STANDARD Test board (76.2 x 114.3 x 1.6mm, 4layers, FR-4) mounting
 7. Mounted on glass epoxy board. (101.5x114.5x1.6mm: based on EIA/JEDEC standard, 2Layers FR-4, with Exposed Pad)
 8. Mounted on glass epoxy board. (101.5x114.5x1.6mm: based on EIA/JEDEC standard, 4Layers FR-4, with Exposed Pad)
- *For 4Layers: Applying 99.5x99.5mm inner Cu area and a thermal via hole to a board based on JEDEC standard JESD51-5

Table2. Operating conditions

T_{amb}=25°C (unless otherwise specified)

Symbol	Parameter	Value	Unit
V _{CC}	Supply voltage (V _{CC} ⁺ - V _{CC} ⁻)	2 to 36	V
V _{icm}	Common mode input voltage range (V _{CC} ⁺ =30V) T _{amb} = 25°C 0 °C ≤ T _{amb} ≤ 70 °C ⁽⁵⁾	0 to V _{CC} ⁺ -1.5 0 to V _{CC} ⁺ -2.0	V
T _{oper}	Operating free-air temperature range	-40 to +125	°C

3 Electrical characteristics

Table3. $V_{CC}^+ = +5V$, $V_{CC}^- = 0V$, $T_{amb} = 25^\circ C$ (unless otherwise specified)

Symbol	Parameter	Min.	Typ.	Max.	Unit
V_{io}	Input offset voltage ⁽¹⁾ $T_{amb} = 25^\circ C$	-	0.5	3	mV
	$0^\circ C \leq T_{amb} \leq 70^\circ C$ ⁽⁵⁾	-	-	5	
I_{io}	Input offset current $T_{amb} = 25^\circ C$	-	0.5	50	nA
	$0^\circ C \leq T_{amb} \leq 70^\circ C$ ⁽⁵⁾	-	-	150	
I_{ib}	Input bias current ⁽²⁾ $T_{amb} = 25^\circ C$	-	20	250	nA
	$0^\circ C \leq T_{amb} \leq 70^\circ C$ ⁽⁵⁾	-	-	400	
A_{vd}	Large signal voltage gain $V_{CC}^+ = 15V$, $R_L = 15k\Omega$, $V_o = 1V$ to $11V$	50	200	-	V/mV
I_{CC}	Supply current (all comparators) $V_{CC}^+ = +5V$, no load	-	0.3	0.5	mA
	$V_{CC}^+ = +30V$, no load	-	0.4	1.2	
V_{id}	Differential input voltage ⁽³⁾	-	-	V_{CC}^+	V
V_{OL}	Low level output voltage ($V_{id} = -1V$, $I_{sink} = 4mA$) $T_{amb} = 25^\circ C$	-	80	400	mV
	$0^\circ C \leq T_{amb} \leq 70^\circ C$ ⁽⁵⁾	-	-	700	
I_{OH}	High level output current ($V_{CC}^+ = V_o = 30V$, $V_{id} = 1V$) $T_{amb} = 25^\circ C$	-	0.1	-	nA
	$0^\circ C \leq T_{amb} \leq 70^\circ C$ ⁽⁵⁾	-	-	1	μA
I_{sink}	Output sink current, $V_{id} = 1V$, $V_o = 1.5V$	6	16	-	mA
t_{re}	Response Time ⁽⁴⁾ $R_L = 5.1k\Omega$ connected to V_{CC}^+	-	1.3	-	μs
t_{rel}	Large Signal Response Time $R_L = 5.1k\Omega$ connected to V_{CC}^+ $e_i = TTL$, $V_{(ref)} = +1.4V$	-	250	-	ns

1. At output switch point, $V_o = 1.4V$, $R_S = 0$ with V_{CC}^+ from 5V to 30V, and over the full common-mode range (0V to $V_{CC}^+ - 1.5V$).

2. The direction of the input current is out of the IC due to the PNP input stage.

3. Positive excursions of input voltage may exceed the power supply level. As long as the other voltage remains within the common-mode range, the comparator will provide a proper output state. The low input voltage must not be less than $-0.3V$ (or $0.3V$ below the negative power supply, if used).

4. The response time specified is for a 100mV input step with 5mV overdrive.

5. This parameter is not 100% test.

NJM390A/NJM391A

TYPICAL CHARACTERISTICS

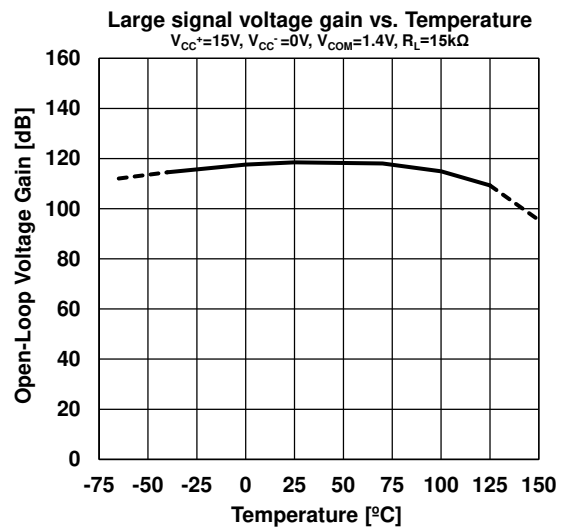
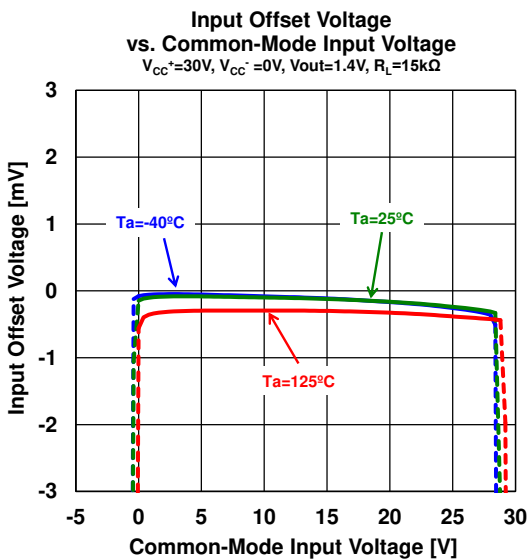
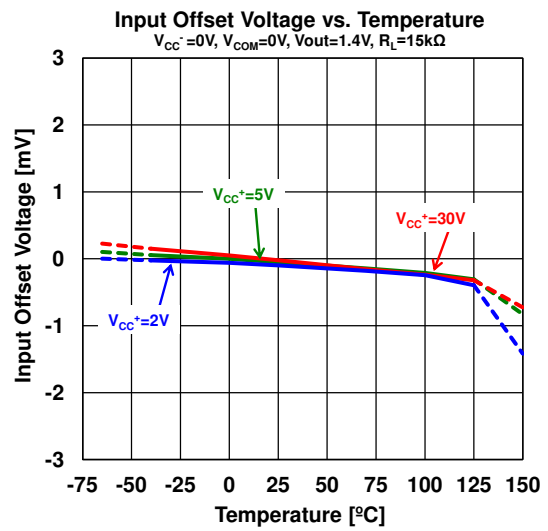
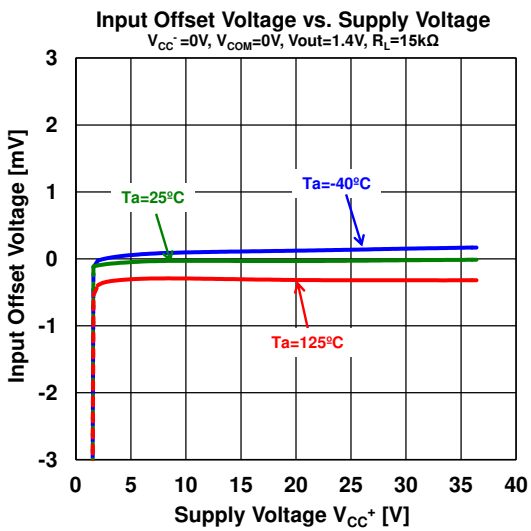
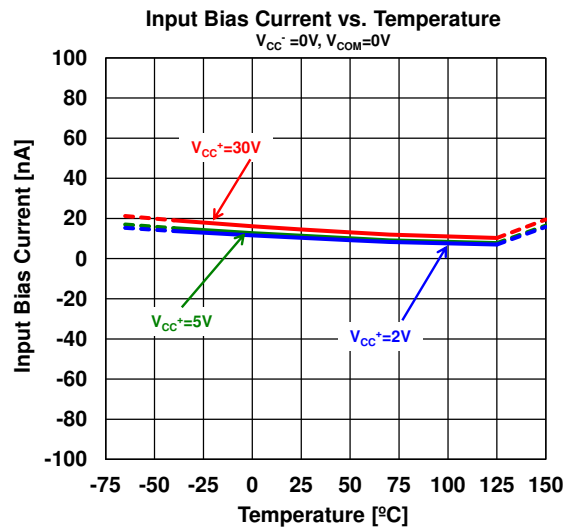
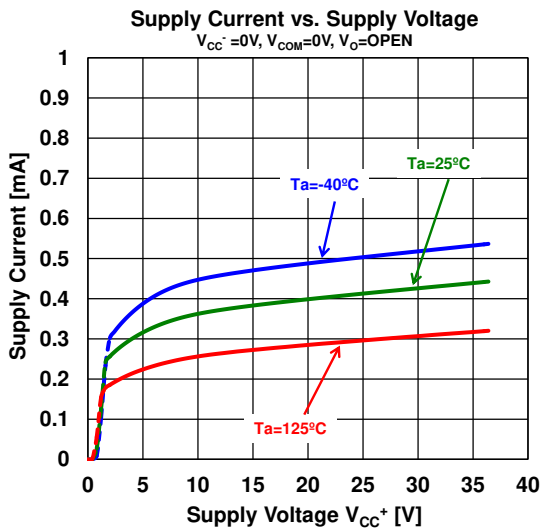

TYPICAL CHARACTERISTICS

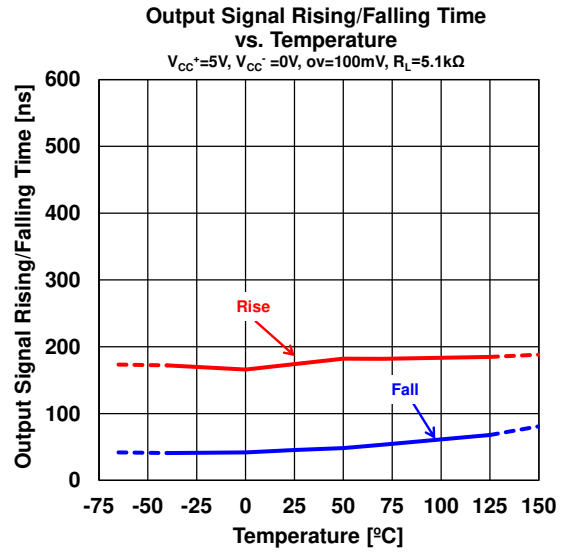
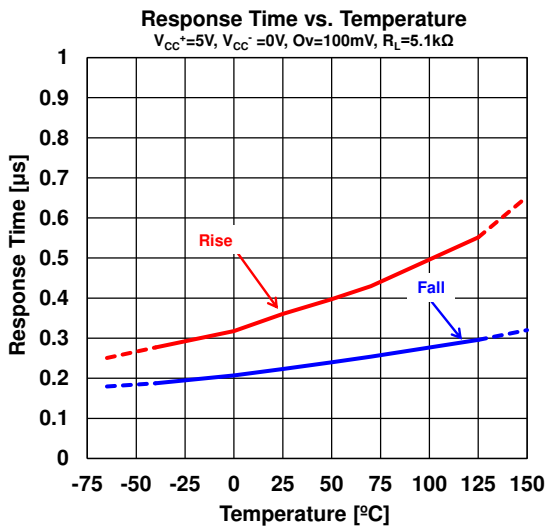
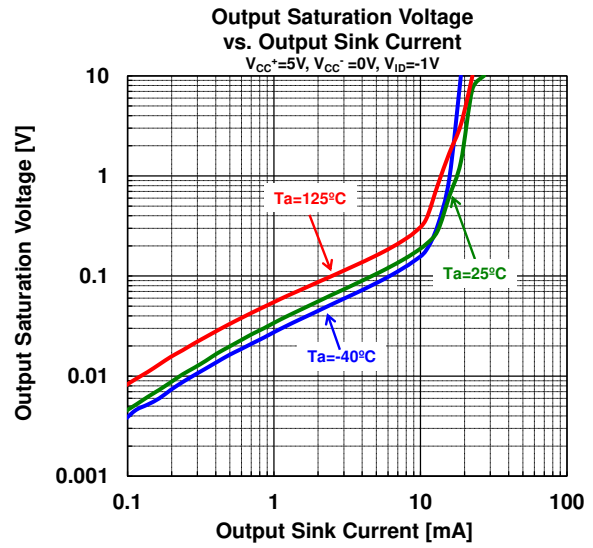
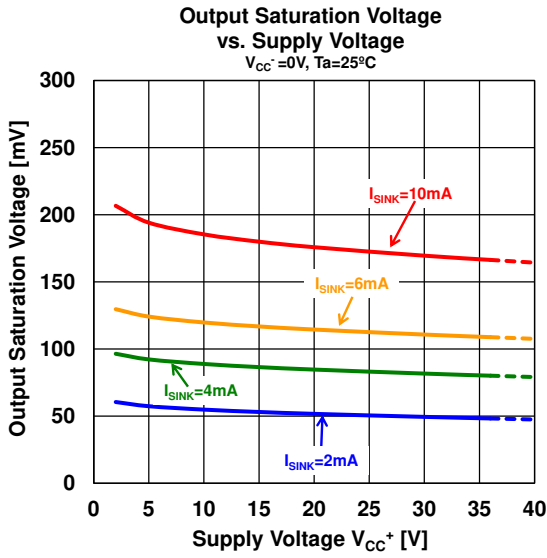

NJM390A/NJM391A

TYPICAL CHARACTERISTICS

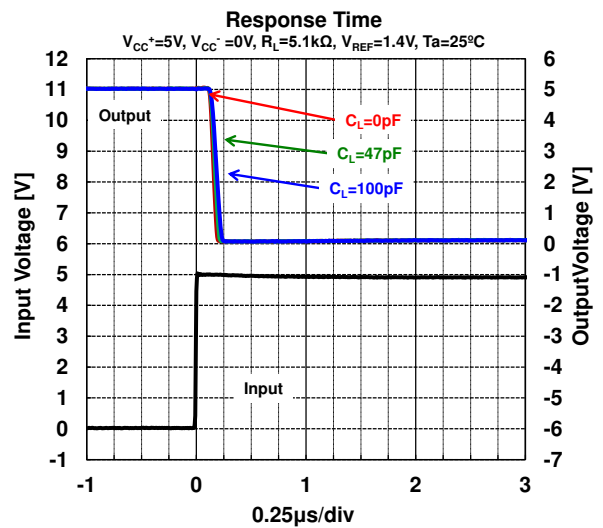
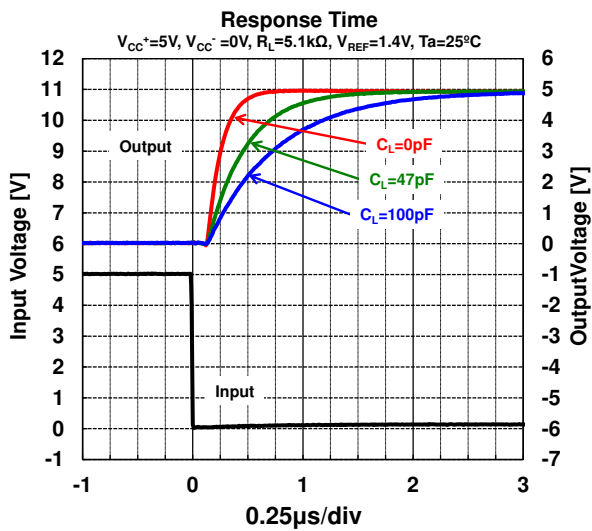
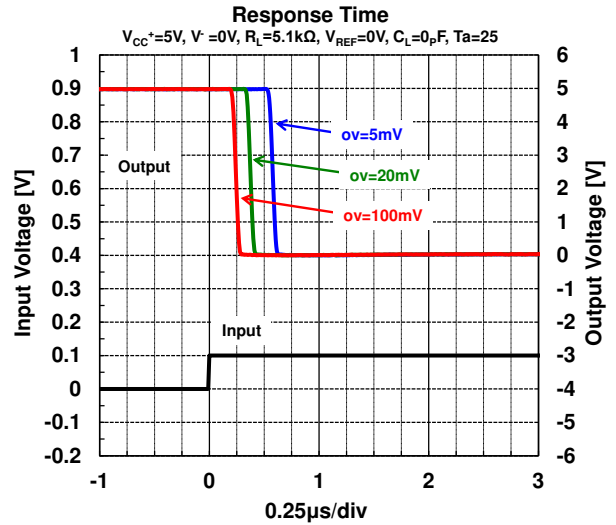
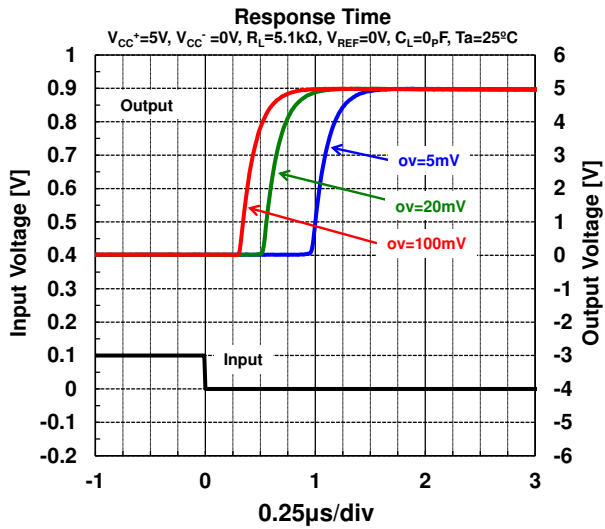

■ PACKAGE OUTLINE UNIT : mm

SOT-23-5

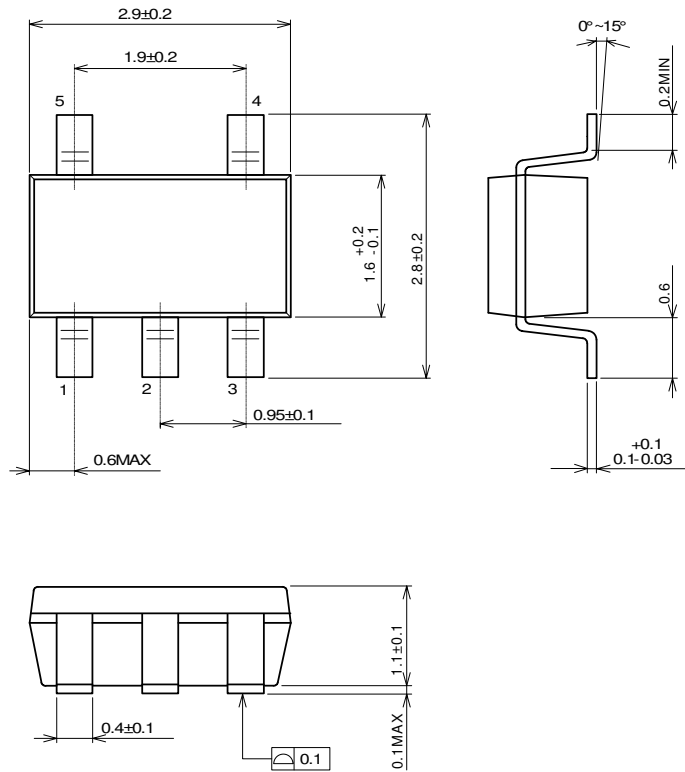

SC-88A

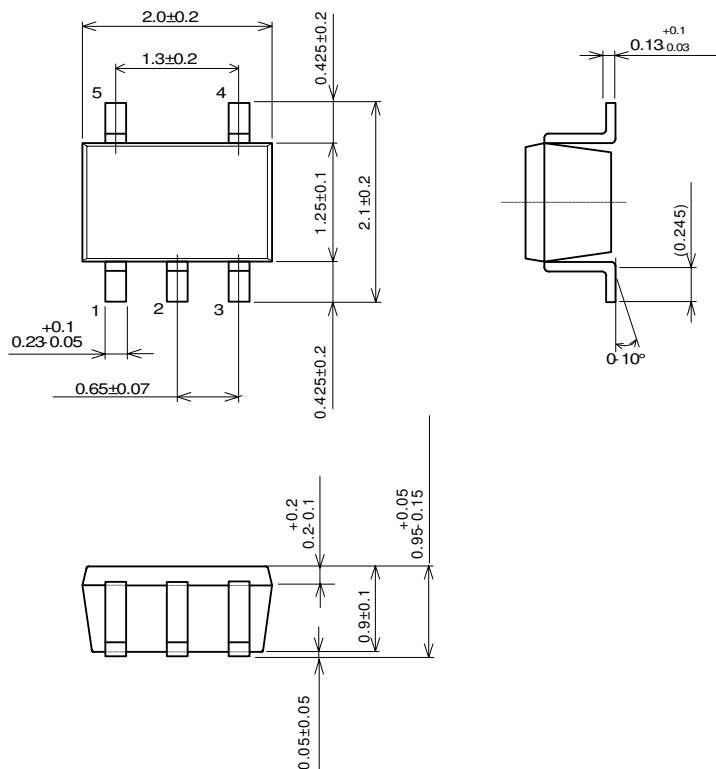

NJM390A/NJM391A

■PACKAGE OUTLINE UNIT : mm

DFN6-G1 (ESON6-G1)

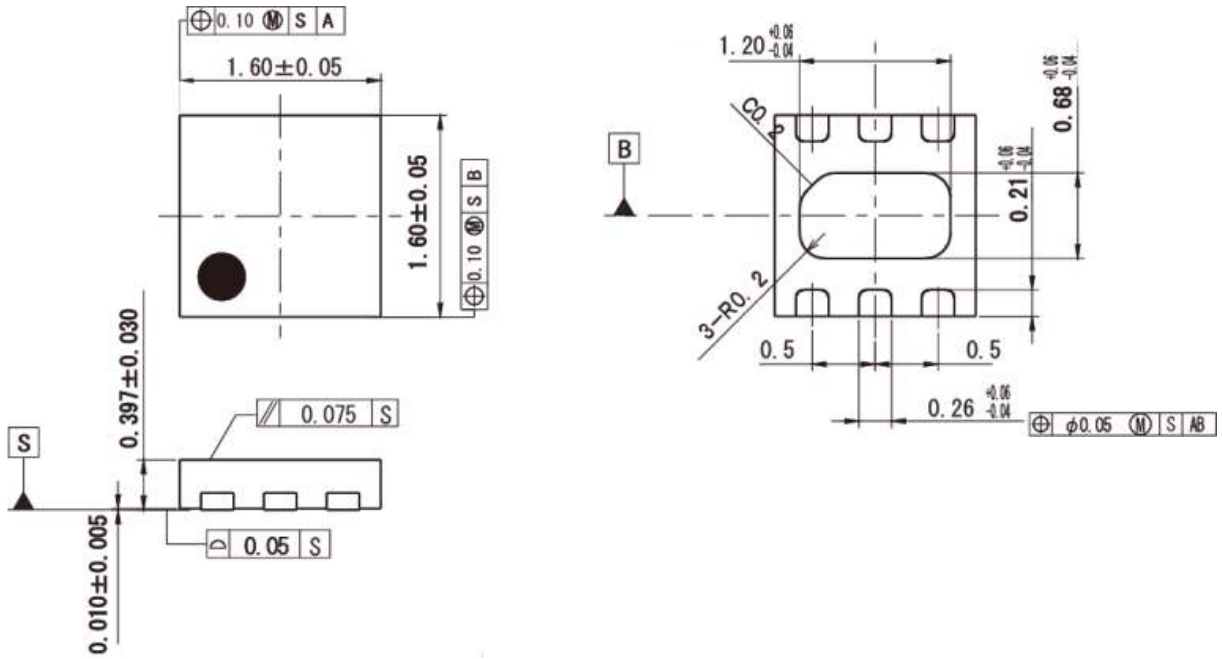

[CAUTION]
 The specifications on this databook are only given for information, without any guarantee as regards either mistakes or omissions. The application circuits in this databook are described only to show representative usages of the product and not intended for the guarantee or permission of any right including the industrial rights.