

**MOUNTING DETAIL**

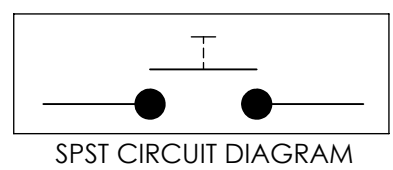
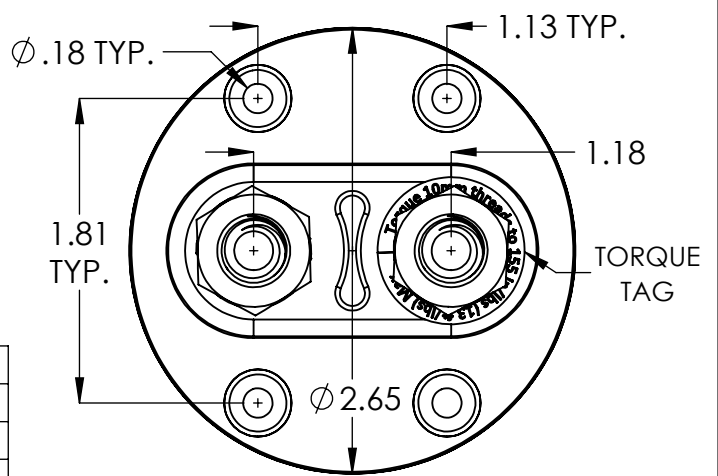
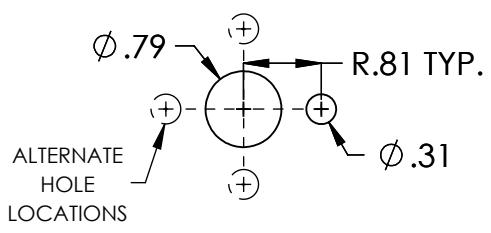

Technical Data	
Key Material:	Plated Steel
Housing Material:	Zinc Diecast
Case Material:	GP Phenolic
Min. Insulation Resistance:	100 Mohm
Dielectric Withstanding Voltage:	1,100V - 1min
Voltage Drop Max:	0.175mV
Voltage:	to 48VDC
Duty Rating:	300A
Overload:	750A - 180sec 1,500A - 30sec
Sealing:	IP67
Vibration:	4G / 50-2kHz
Shock:	6G / 11ms
Temperature Range:	-40 to +85C
Terminal Torque:	155 in.lbs
Mounting Torque:	18 ft.lbs

**PROPRIETARY AND CONFIDENTIAL**  
 This document contains proprietary data for products designed by Shallco, Inc., of Smithfield, NC. No disclosure; reproduction, or use of any part thereof may be made except by written permission.

	NAME	DATE
DRAWN	JRT	12-21-16
CHECKED		
ENG APPR.	RMF	12-21-16
MFG APPR.		
Q.A.		

**SHALLCO**  
 308 COMPONENTS DRIVE, SMITHFIELD, NC 27577 USA  
 DO NOT SCALE DRAWING

TITLE: **KEYED BATTERY DISCONNECT 48VDC-300AMP**

BLANK WEIGHT: - PART WEIGHT: 0.7 LBS

SCALE: 1:2 DWG. NO. **503D-300** SHEET 1 OF 1 REV. **B**  
 FILENAME: 503D-300 WEBSITE: www.shallco.com

DWG NO: 503D-300