

High power white led driver

General features

- Buck-boost DC/DC Converter
- Drives one power white led:
up to 600mA between 2.7 to 4.5V
- Led temperature protection
- Output current control
- 1.8 MHz (typ) fixed frequency PWM
- Synchronous rectification
- High efficiency across the total input voltage range
- Operational modes:
 - Shutdown mode
 - Shutdown mode with NTC
 - Flash mode up to 600 mA
 - Medium flash mode
 - Torch mode: up to 250 mA
- Adjustable current in all three modes
- LED disconnected from the battery in shutdown mode
- Programmable safety shutdown in flash mode
- LED short and open circuit protection
- Overvoltage protection
- < 1µA Shutdown current
- QFN20 4mm x 4 mm package

Applications

- Cell phone and smart phones
- Camera flashes/strobes
- PDAS and digital still cameras

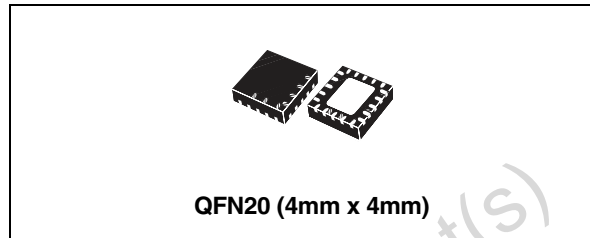

Description

The STCF02 is a high efficiency power supply solution to drive a single flash LED in camera phone, PDAs and other hand-held devices. It is a buck-boost converter that guarantees a proper LED current control over the battery voltage (particularly in the case, when the output voltage is lower than the input voltage); the output current control ensures a good current regulation over the forward voltage spread characteristics of the Flash LED.

Three logic input signals can select 5 modes of operation: Shutdown mode (quiescent current less than 1µA typ), Shutdown mode with NTC active, Torch mode (drives the LED up to 250mA), Flash mode (up to 600mA), and Medium flash mode (reduces the flash current).

This highly efficient converter is able to accept input current from the battery (lower than 1.5A), while limiting the peak inductor current to 2.3A (typ). Other features include Soft start control, thermal shutdown, short circuit protection, overvoltage protection, and LED temperature protection. An alternative to LED temperature protection is that a safety flash time-out feature can be implemented instead. This device is available in a QFN20, 4mm x 4mm, no-lead package (height is less than 1mm).

Order code

Part number	Package	Packaging
STCF02PNR	QFN20 (4x4 mm)	4500 parts per reel

Contents

1	Application	3
2	Pin connections	4
3	Maximum ratings	6
4	Characteristics	7
5	Typical characteristics	9
6	Detailed operating description	11
6.1	Introduction	11
6.2	Buck-Boost converter	11
6.3	Flash mode	11
6.4	Medium flash mode	12
6.5	Torch mode	13
6.6	Shutdown mode	13
6.7	Soft start	14
6.8	LED Failure Protection	14
6.9	Overvoltage protection	14
6.10	Thermal shutdown protection	14
6.11	Sensing of LED temperature by NTC resistor	14
6.12	Safety shutdown in flash mode	15
7	Package mechanical data	16
8	Revision history	18

1 Application

Figure 1. Application circuit

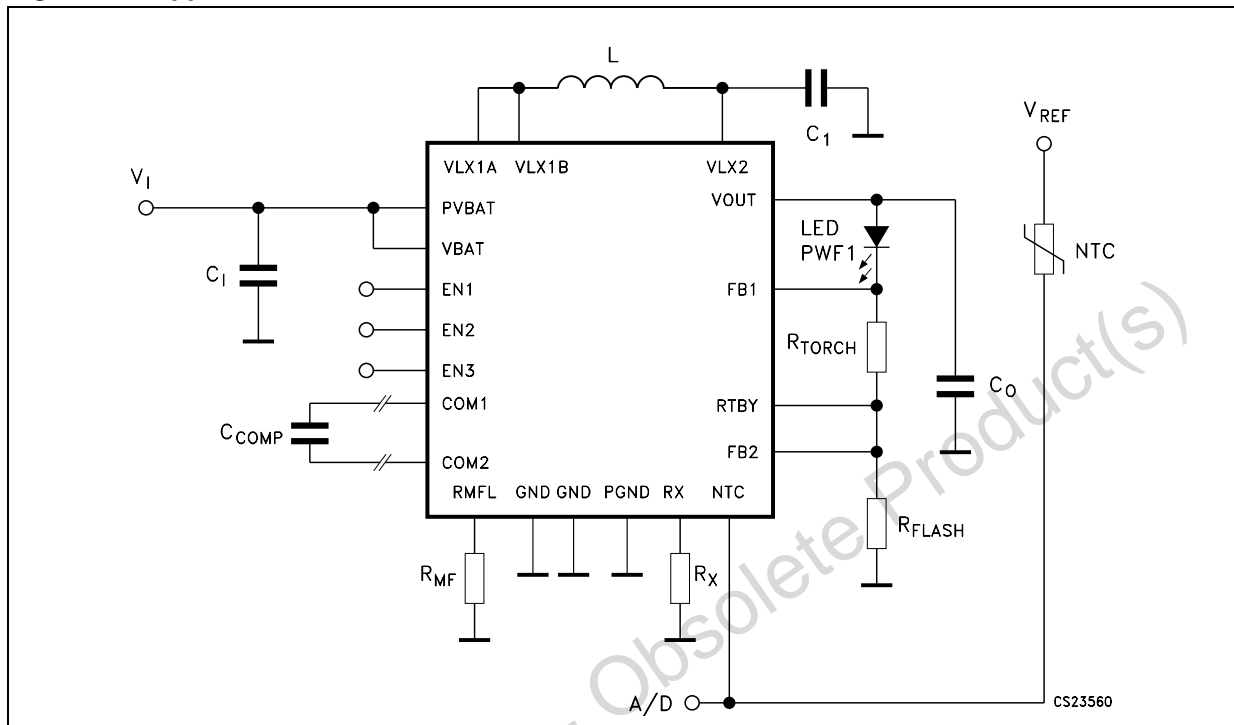

Table 1. External components

Symbol	Parameter	Min.	Typ.	Max.	Unit
R _{FLASH}	Sensing flash current resistor - thick film type (0805)		0.27		Ω
R _{TORCH}	Sensing torch current resistor - thick film type (0603)		6.2		Ω
R _{MF}	Setting resistor for middle flash mode - thick film type (0402)		8200		Ω
C ₁	Two Input filtering capacitor TDK C1608X5R0J106MT - Ceramic type (0603) 6.3V		10	2x10	μF
C _O	Output capacitance - Ceramic type 0603 6.3V		4.7		μF
L	TDKVL5014A-4R7		4.7		μH
	INDUCTANCE		0.12		Ω
	DCR				
NTC	Negative thermistor - NCP18WF104J03RB - Thick film type		100		kΩ
C _{COMP}	Compensation capacitor - 0402	100		820	pF
R _X	Reference resistor - 0402		15		kΩ
C1	Ceramic Capacitor		47		pF

Note:

- The external components proposal should be considered as a design reference guide. The performances mentioned in the electrical characteristics table are not guaranteed for all the possible electrical parameters of the components included in this list. On the other hand the operation of STCF02 is not limited with the use of the external components listed above.
- The C_{COMP} is optional and may be used if the error amplifier bandwidth (which by default is set to 2 KHz) has to be decreased because of an unstable driver function. Unstable operation could be caused by using different values of inductor and output capacitor then recommended.

2 Pin connections

Figure 2. Pin configuration (bottom view)

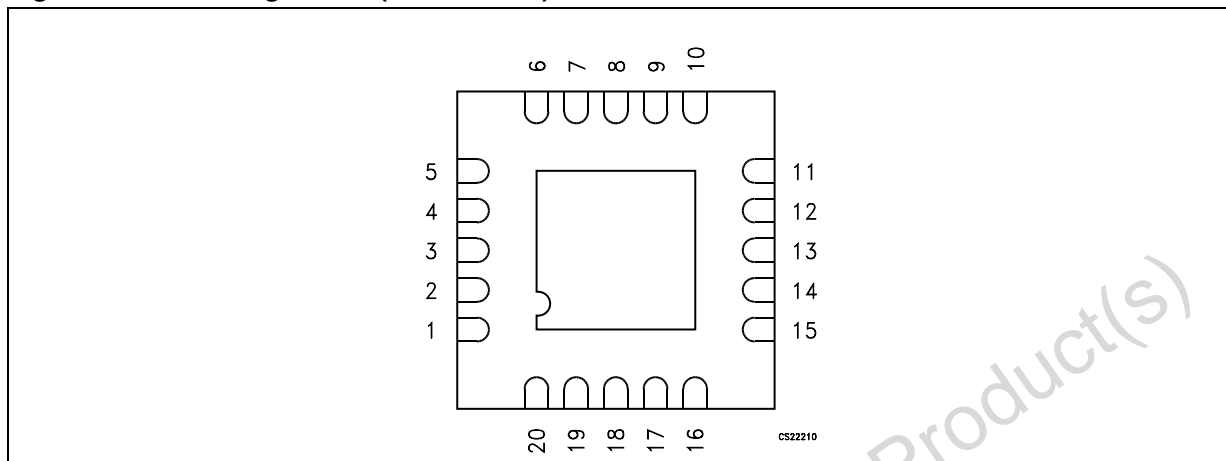
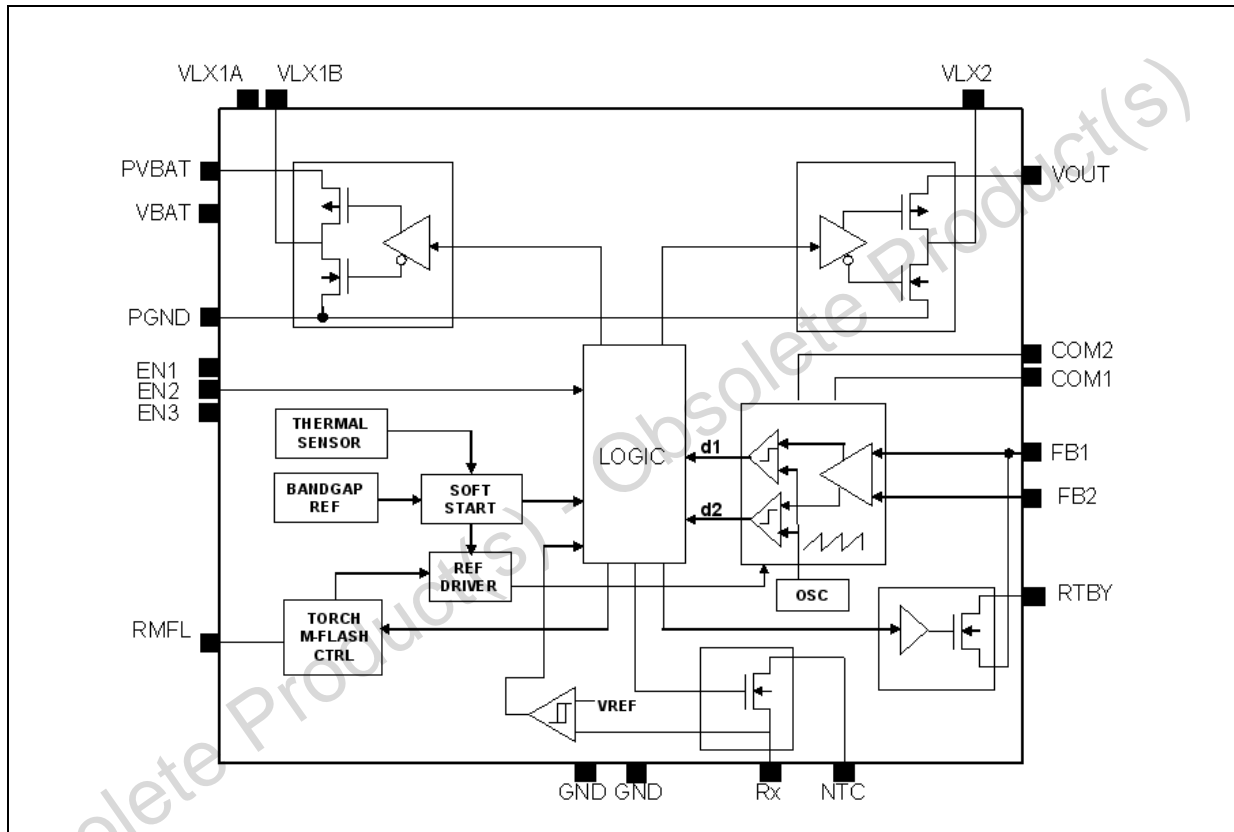

Table 2. Pin description

Pin N°	Symbol	Name and function	Note
1	VLX2	Inductor connection	External coil is connected between this pin and VLX1. It should be placed as close as possible to the device in order to minimize resistance which cause losses.
2	RX	Rx Resistor connection	Rx resistor is connected between this pin and ground to set LED over temperature threshold.
3	V _O	Output voltage	Anode of the LED is connected to this pin.
4	NTC	NTC Resistor connection	This pin is used for the LED temperature sensing using an external NTC resistor.
5	FB1	Feedback pin for torch mode	This pin is used for current sensing in Torch mode – Cathode of the Flash LED and RTorch resistor are connected to this pin.
6	RTBY	R _{TORCH} Bypass	This pin is used to short-circuit the R _{TORCH} during FLASH and MIDDLE FLASH MODE.
7	FB2	Feedback pin for flash mode	This pin is used to sense the voltage across R _{FLASH} . It must be directly connected to the non-grounded terminal of R _{FLASH} .
8, 10	GND	Signal ground	This is the signal ground pin related to digital and analog signals and must be connected as close as possible to the sensing resistor.
9	COM1	Compensation connection	Optional external compensation should be connected to these pins.
11	COM2	Compensation connection	Optional external compensation should be connected to these pins.
12	VBAT	Supply voltage	Supply pin of the device.
13	PVBAT	Power supply voltage	Power supply pin of the device.
14	VLX1A	Inductor connection	External coil is connected between these pins and VLX2. They should be placed as close as possible to the device in order to minimize resistance which causes losses. It is mandatory to connect VLX1A and VLX1B together.
15	VLX1B		
16	EN3	Enable Pin 3	Digital input that allows selection of the operational modes of the device (refer to truth table).
17	EN2	Enable Pin 2	Digital input that allows selection of the operational modes of the device (refer to truth table).

Pin N°	Symbol	Name and function	Note
18	PGND	Power ground	Power ground pin for power analog circuit. To be connected to the PCB ground plane.
19	RMFL	Middle flash resistor connection	This pin is used for the current setting in Middle Flash Mode – RMF resistor is connected to this pin.
20	EN1	Enable Pin 1	Digital input that allow selecting the operational modes of the device (refer to truth table).
Exp-pad	PGND	Power ground	To be connected to the PCB Ground Plane for optimal electrical and thermal performance.

Figure 3. Block diagram



3 Maximum ratings

Table 3. Absolute maximum ratings

Symbol	Parameter	Value	Unit
V _{BAT}	Signal supply voltage	-0.3 to 6	V
PV _{BAT}	Power supply voltage	-0.3 to 6	V
EN _{1,2,3}	Enable input	-0.3 to 6	V
V _O	Output voltage	-0.3 to 6	V
VLX1A-VLX1B	Inductor connection 1	-0.3 to V _I + 0.3	V
VLX2	Inductor connection 2	-0.3 to V _O + 0.3	V
FB1	Feedback for torch current	-0.3 to 3	V
FB2	Feedback for flash current	-0.3 to 3	V
RTBY	MOS Switch connection	-0.3 to 3	V
RX	Connection for reference resistor	-0.3 to 3	V
RMFL	Connection for setting resistor for middle flash	-0.3 to 6	V
NTC	LED temperature sensing connection	-0.3 to 6	V
COM1,COM2	Compensation connection	-0.3 to 3	V
T _{OP}	Ambient operating temperature ⁽¹⁾	-40 to + 85	°C
T _{STG}	Storage temperature range	-65 to + 150	°C
V _{ESD}	ESD rating	2	KV

1. STCF02 is guaranteed to meet specification from 0°C to 70°C – specifications over the -40°C to 85°C operating temperature range are assured by design, characterization and correlation with statistical process control.

Table 4. Thermal data

Symbol	Parameter	Value	Unit
R _{thJA}	Thermal resistance junction-ambient (*)	59	°C/W

(*) Typical Application on a two layer board.

4 Characteristics

Table 5. Electrical characteristics
(All typical values are referred to $T_A = 25^\circ\text{C}$, $V_I = 3.6\text{V}$)

Symbol	Parameter	Test Conditions	Min.	Typ.	Max.	Unit
V_I	Input Operating Voltage		2.7		5.5	V
I_{CC}		Torch mode	616	686	757	μA
		Medium flash mode	590	688	733	
		Flash mode	555	660	728	
V_{UVLO}	Under voltage lockout threshold	V_I rising	5.1		5.3	V
		V_I falling	5.1		5.3	
I_O	Output Current Adjustment Range, I_{FLASH}	Flash mode for $V_I = 2.7\text{V}$ to 4.5V $R_{FLASH_MIN}=1.6\Omega$ to $R_{FLASH_MAX}=0.27\Omega$	100		600	mA
	Output Current Adjustment Range, I_{MFLASH}	Medium flash mode for $V_I = 2.7\text{V}$ to 4.5V $R_{MFLASH_MIN}=1.1\text{k}\Omega$ to $R_{MFLASH_MAX}=500\text{k}\Omega$	25%		I_{FLASH}	
	Output Current Adjustment Range, I_{TORCH}	Torch mode $V_I = 2.7\text{V}$ to 4.5V $R_{TORCH}+R_{FLASH}=6.4\Omega$ to $R_{TORCH}+R_{FLASH}=0.64\Omega$	25		250	
ΔI_O	Output current variation	Flash and medium flash mode ⁽¹⁾		± 10		%
		Torch mode		± 5		%
V_O	Regulated voltage range		2.5		5.1	V
FB1,2	Feedback Voltage	Flash Mode	150	160	170	mV
I_Q	Quiescent Current in Stand By	EN1=EN2=EN3=0		1		μA
		EN1=EN2=0 EN3=X (NTC ON)		3		
f	Frequency	$V_I = 2.7\text{V}$		1.8		MHz
e1	Efficiency	Application Circuit Figure 2 $V_I = 3.2\text{V}$ to 4.2V , $I_O=600\text{mA}$	78	85		%
e2		Application Circuit Figure 2 $V_I = 3.2\text{V}$ to 4.2V , $I_O=25\text{mA}$	72	75		%
I_{PK}	Inductor peak current	$V_I = 2.7\text{V}$, $I_O=600\text{mA}$		1.23		A
OVP	Over voltage protection	$V_I = 4.2\text{V}$ No load	5.2			V
OTP	Over temperature protection	$V_I = 2.7\text{V}$ to 4.5V (Note: 1)		140		$^\circ\text{C}$
OT _{HYST}	Overtemperature hysteresis	$V_I = 2.7\text{V}$ to 4.5V (Note: 1)		20		$^\circ\text{C}$
NTC	Voltage Reference	$V_I = 4\text{V}$, $I_{NTC} = 2\text{mA}$ max		1.192		V
NTC _{HYST}	Hysteresis			0.3		V
NTC _{LEAK}	Voltage Reference leakage	EN1=EN2=0, EN3=X			± 1	μA
EN1, EN2, EN3	Logic signals level	Disable Low V_{IL}			0.4	V
		Enable High V_{IH}	1.4			
I_ENx	Enable input current				± 1	μA
T _{FLTR}	Transition time from PIN (Flash) to PIN (Torch) (see Figure 11)	PIN ($I_O=600\text{mA}$) to PIN ($I_O=100\text{mA}$) (Note: 1)			30	μs
T _{ON}	Led current rise time $I_{LED} = 0$ to $I_{LED} = \text{max}$ (see Figure 13)	EN1=EN2=0 to EN1=0 & EN2=1 or EN1=EN2=1 (Note 1)			2	ms

1. Not include tolerance of sensing resistor

Note: 1 Guaranteed by design



Table 6. Truth table selection mode

EN1	EN2	EN3	I _{LED}	I _{LED_MAX} (mA)	Mode	NTC
0	0	X	0	0	Shutdown	OFF
1	0	1	0	0	Shutdown	ON
0	1	X	$I_{TORCH} = 160mV / (R_{TORCH} + R_{FLASH})$	250	Torch	ON
1	1	1				
1	0	0	$I_{MFLASH} = f(I_{FLASH}, R_{MFLASH})$	500	Medium Flash	ON
1	1	0	$I_{FLASH} = 160mV / R_{FLASH}$	600	Flash	ON

Obsolete Product(s) - Obsolete Product(s)

5 Typical characteristics

Figure 4. I_{IN} vs V_{IN} in torch mode

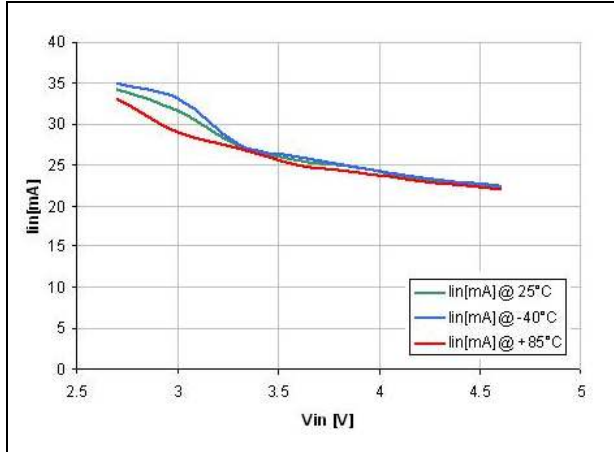

Figure 5. I_O vs V_{IN} in torch mode 25 mA

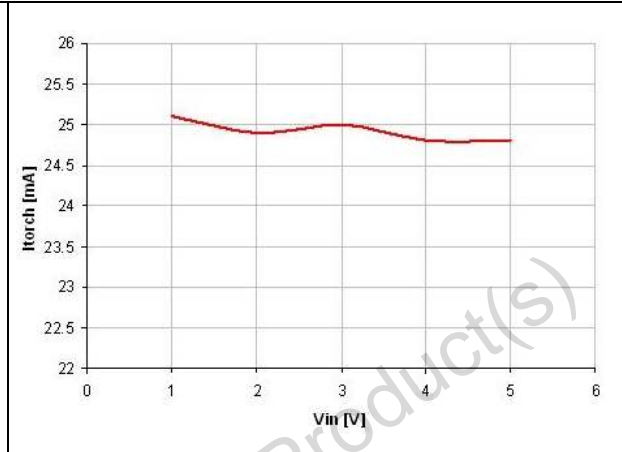

Figure 6. I_O vs V_{IN} in flash mode 600 mA

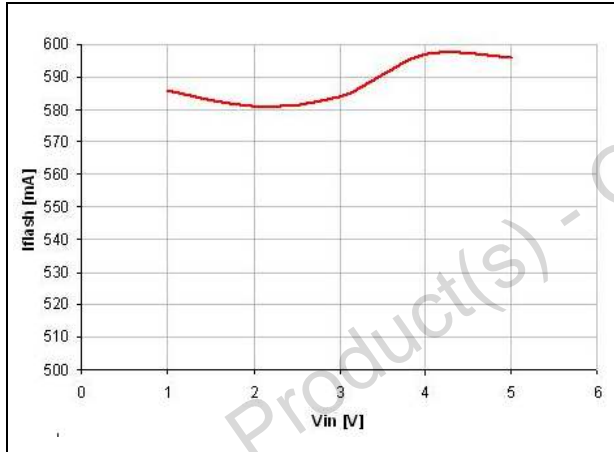

Figure 7. V_{FB1} vs temp in torch mode

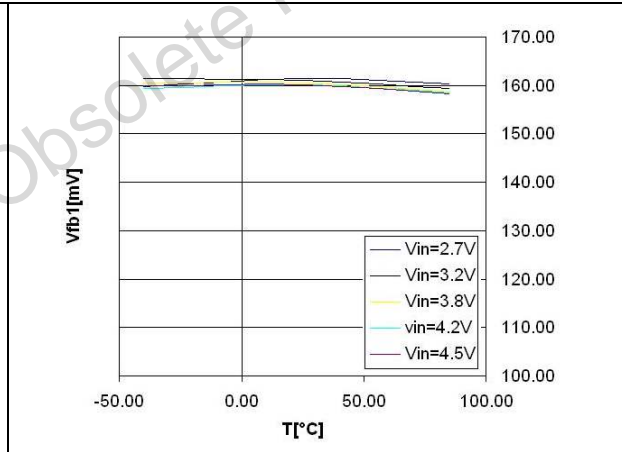

Figure 8. Efficiency vs I_O in torch mode

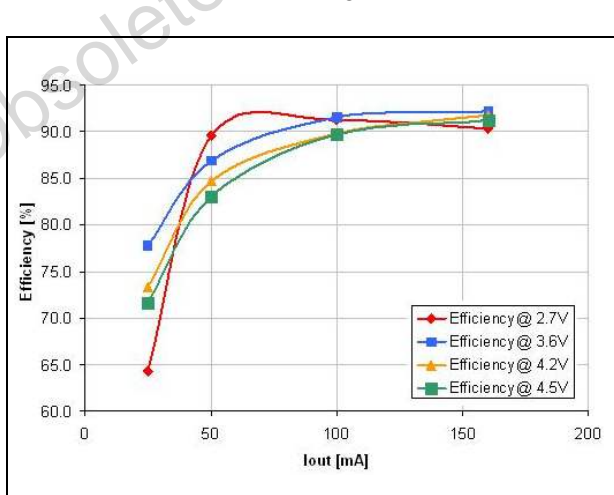

Figure 9. Start-up to torch mode 25 mA at $V_{BATT} = 3.6V$

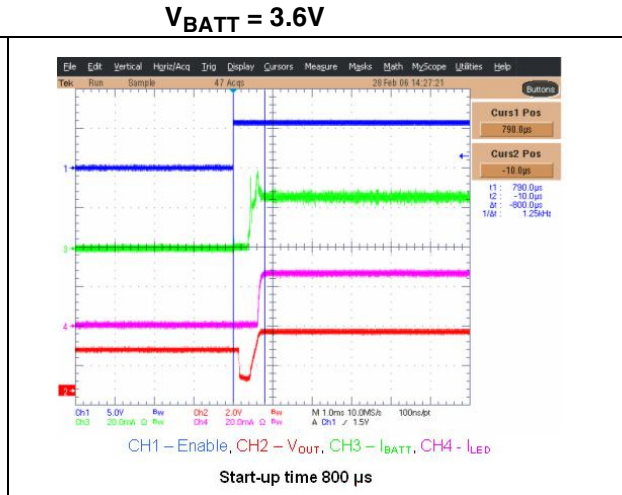
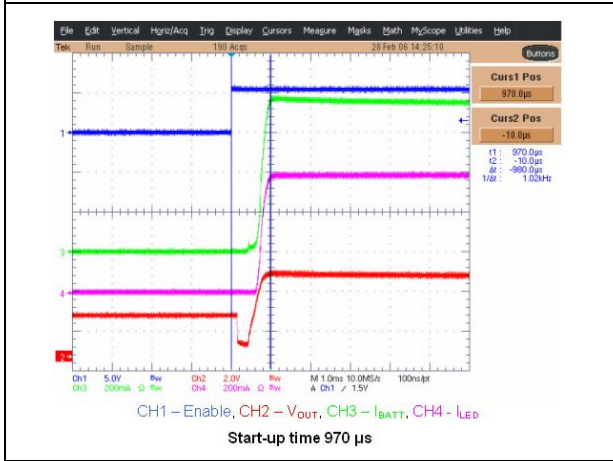

Figure 10. Start-up to flash mode 600 mA at $V_{BATT} = 3.6V$



Obsolete Product(s) - Obsolete Product(s)

6 Detailed operating description

6.1 Introduction

The STCF02 is a buck-boost converter, dedicated to power and control the current of a Power White Led in a camera cell Phone. The device operates at a constant switching frequency of 1.8MHz typ. It provides an output voltage down to 2.5V and up to 5.1 V, from a single cell 2.7 V to 5.5 V lithium-ion battery. The flash current is adjustable from 100mA to 600mA for the input voltage range from 2.7V to 4.5V. Torch current is adjustable from 25mA to 250mA. The device also includes a medium flash mode with the current set between the 25% of flash current and flash current. The device contains a pin for connection of NTC which senses the temperature of the LED.

6.2 Buck-Boost converter

Regulation of the PWM controller is made by sensing the current of the led through the R_{FLASH} resistor (see [Figure 2](#)). Depending on the forward voltage of the Flash LED, the device can automatically change the operation mode between buck (step down) and boost (step up) mode. Three case can occur:

Boost region ($V_O > V_{BAT}$): this configuration is used in most cases, as the output voltage ($V_O = V_{fLED} + I_{LED} \times R_{FLASH}$) is higher than V_{BAT} ; Buck region ($V_O < V_{BAT}$); Buck / Boost region ($V_O \sim V_i$).

6.3 Flash mode

To select Flash mode the Enable pins have to be connected as follows: EN1=1, EN2=1, EN3=0.

The STCF02 operates continuously to supply maximum current to the flash LED (up to 600 mA).

The flash current can be adjusted by the R_{FLASH} resistor. The control loop uses the FB2 pin to sense the voltage across R_{FLASH} . The flash current is then programmed at:

$$I_{FLASH} = 160\text{mV} / R_{FLASH}$$

For a flash current programmed at 600mA, the sensing resistor is equal to 0.27Ω

During this operation mode the MOS Switch between FB1 and RTBY pins is closed.

If the EN3 is forced to High during Flash mode operation, the current is reduced to that of Torch mode. Such reduction of input power during transition from Flash to Torch mode is achieved within less than 30µs. The NTC divider for measuring LED temperature is active.

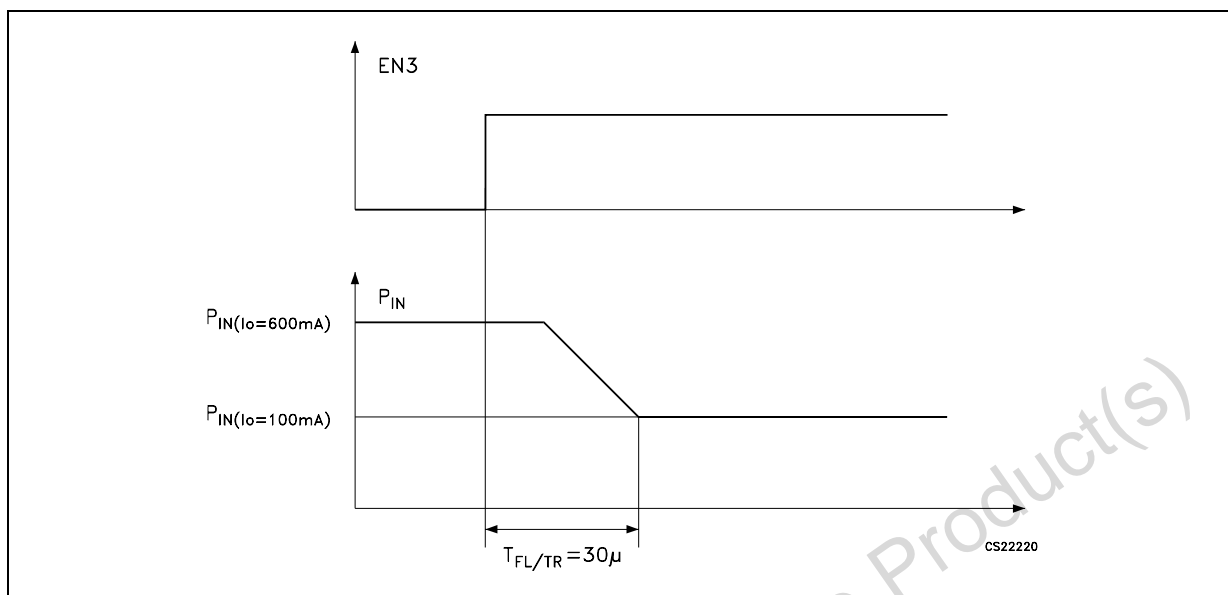
Figure 11. Reducing power during the EN3

6.4 Medium flash mode

To select this operating mode the Enable pins have to be connected as follows:

EN1=1, EN2=0, EN3=0

In medium flash mode the current is set between the Torch and the flash mode levels and can be adjusted by connecting a resistor between the RMFL pin and the ground:

The medium flash current is then programmed using the following equation:

$$I_{MF} = 10^{-5} / R_{FL} \cdot [3000 + (13000 \cdot R_{MF} / (13000 + R_{MF}))]. \text{ (See [Figure 12](#)).$$

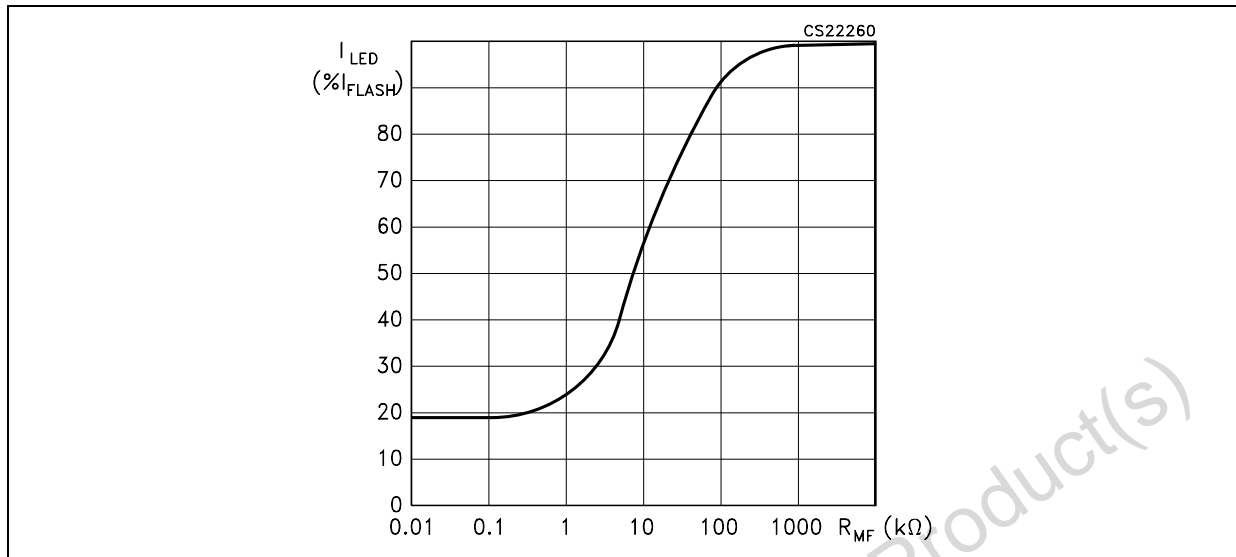
Figure 12. Middle Flash Current (as a percentage of flash current) vs R_{MF} 

6.5 Torch mode

To select this operating mode the Enable pins have to be connected to any one of the follow states:

EN1 = 0, EN2 = 1, EN3 = x

EN1 = 1, EN2 = 1, EN3 = 1.

The STCF02 can continuously provide a torch current adjustable between 25mA and 250mA. The torch current adjustment is made by resistor R_{TORCH} (Figure 2). The control loop uses the FB1 pin to sense the voltage across $R_{FLASH}+R_{TORCH}$. The torch current is then programmed using the following equation:

$$I_{TORCH} = 160\text{mV} / (R_{FLASH} + R_{TORCH})$$

If the programmed Flash current is 600mA ($R_{FLASH} = 0.27\Omega$) and a 250mA Torch current is needed, the R_{TORCH} resistance is equal to 0.37Ω

During Torch operation mode the MOS Switch between FB1 and RTBY pins is opened.

The NTC divider for measuring LED temperature is active.

6.6 Shutdown mode

When the device is not used, two shutdown modes are available. They can be selected by the enable pins:

EN1=0, EN2=0, EN3=X

With this combination the NTC divider for measuring of LED temperature is not active. The quiescent current is less than $1\mu\text{A}$.

EN=1, EN2=0, EN3=1

This combination of enable pins provides shutdown modes with an active NTC divider for sensing LED temperature. This Mode is useful for measuring the temperature before starting both TORCH and FLASH MODE operations.

6.7 Soft start

To avoid spikes the battery during start-up sequence, a soft start function has been implemented. This soft start is achieved by progressively increasing the feedback voltage reference. In the worst case scenario the start up time as defined below ($I_O = I_{MAX}$) will not exceed 6ms.

Figure 13. Start up - LED current rise time

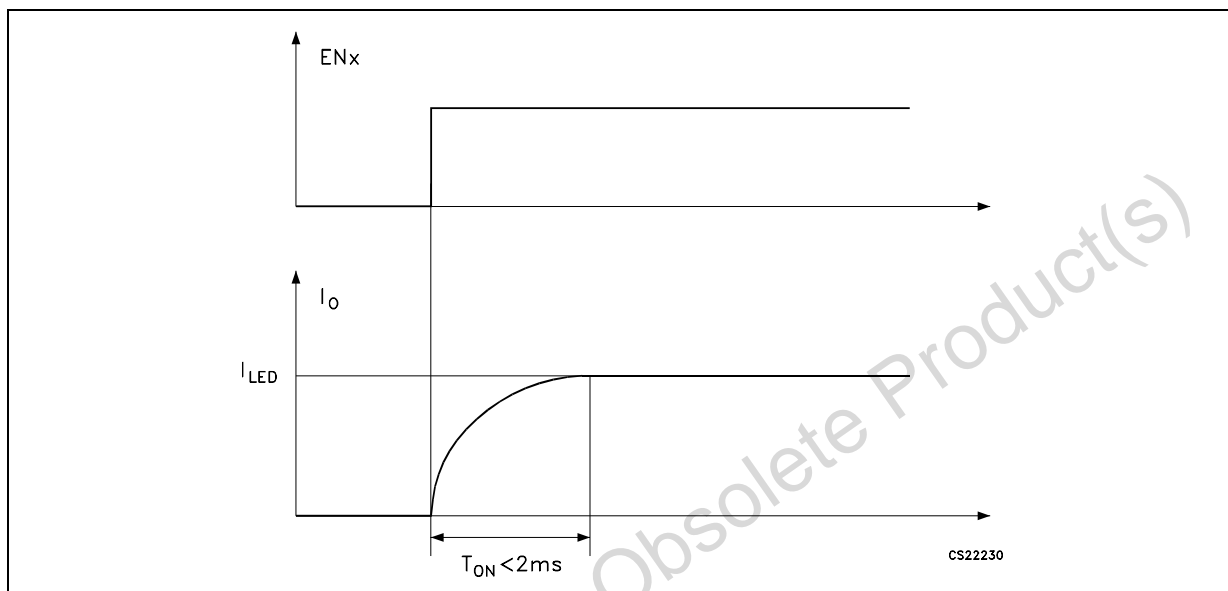

6.8 LED Failure Protection

The device is self protected when the LED fails as a result of a short or open circuit. Such performances are tested using a standard mobile phone Lithium battery with internal resistance 170mΩ typ.

6.9 Overvoltage protection

The device includes a power switch protection that stops the operation of the PWM controller when the voltage at the pin V_O exceeds the OVP threshold.

6.10 Thermal shutdown protection

Internal thermal shutdown protection will switch off the device when the junction temperature exceeds 140°C typical. The hysteresis comparator allows for the automatic restart of the PWM controller, when the temperature is reduced by 20°C.

6.11 Sensing of LED temperature by NTC resistor

The device is able to switch off the power circuit, if high temperature on the LED is detected (see [Figure 14](#)).

6.12 Safety shutdown in flash mode

To avoid LED burning during flash mode, which could be brought on by a micro-controller fault, a simple programmable R_C circuit is possible to shutdown the device after a selected time through the R_X Pin (see Figure 15).

Figure 14. Typical application of LED temperature sensing by NTC resistor

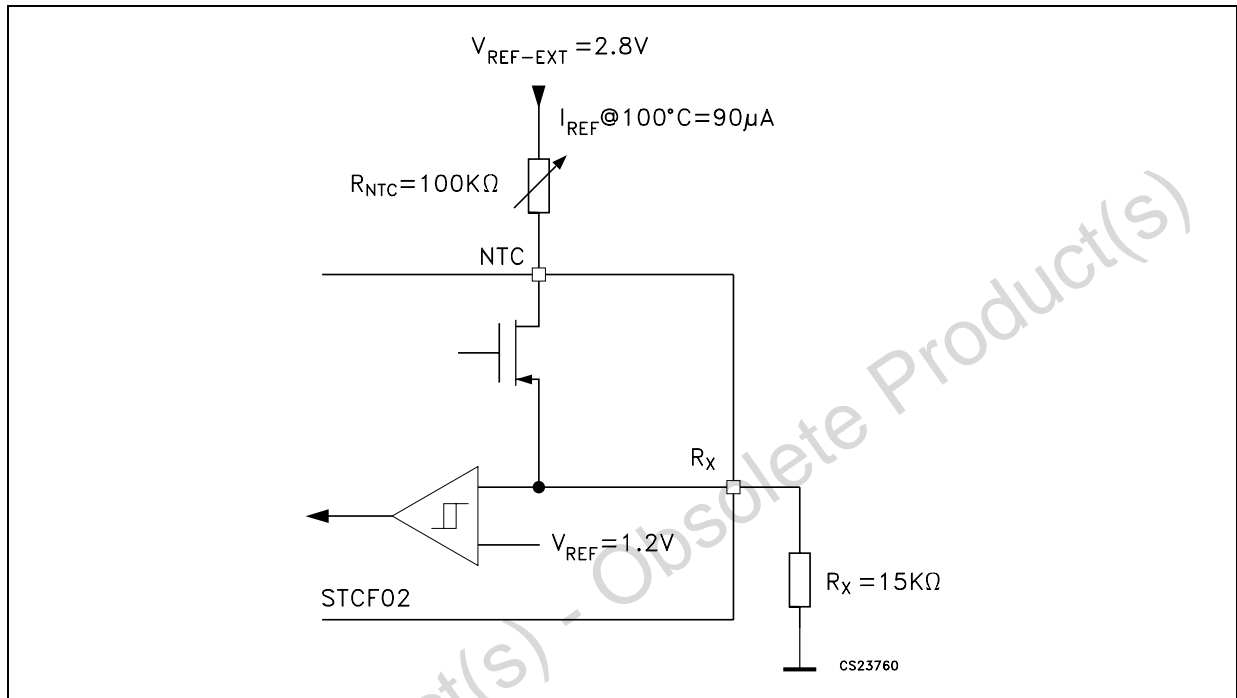
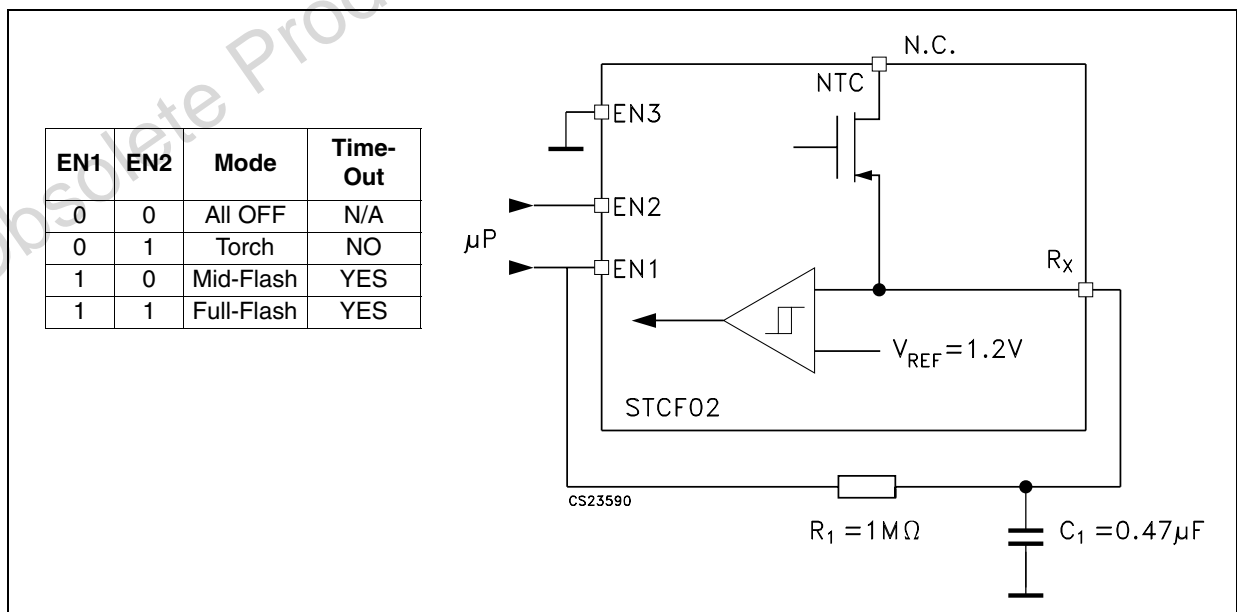

Figure 15. Typical Application of Safety Shutdown



7 Package mechanical data

In order to meet environmental requirements, ST offers these devices in ECOPACK® packages. These packages have a Lead-free second level interconnect. The category of second level interconnect is marked on the package and on the inner box label, in compliance with JEDEC Standard JESD97. The maximum ratings related to soldering conditions are also marked on the inner box label. ECOPACK is an ST trademark. ECOPACK specifications are available at: www.st.com.

Obsolete Product(s) - Obsolete Product(s)

QFN20 (4x4) MECHANICAL DATA

DIM.	mm.			mils		
	MIN.	TYP	MAX.	MIN.	TYP.	MAX.
A	0.8	0.9	1.00	31.5	35.4	39.4
A1		0.02	0.05		0.8	2.0
A2		0.65	1.00		25.6	39.4
A3		0.25			9.8	
b	0.18	0.23	0.30	7.1	9.1	11.8
D	3.875	4.00	4.125	152.6	157.5	162.4
D2	0.75	1.7	2.25	29.5	66.9	88.6
E	3.875	4.00	4.125	152.6	157.5	162.4
E2	0.75	1.7	2.25	29.5	66.9	88.6
e	0.45	0.50	0.55	17.7	19.7	21.7
L	0.35	0.55	0.75	13.8	21.7	25.9
ddd			0.08			3.1

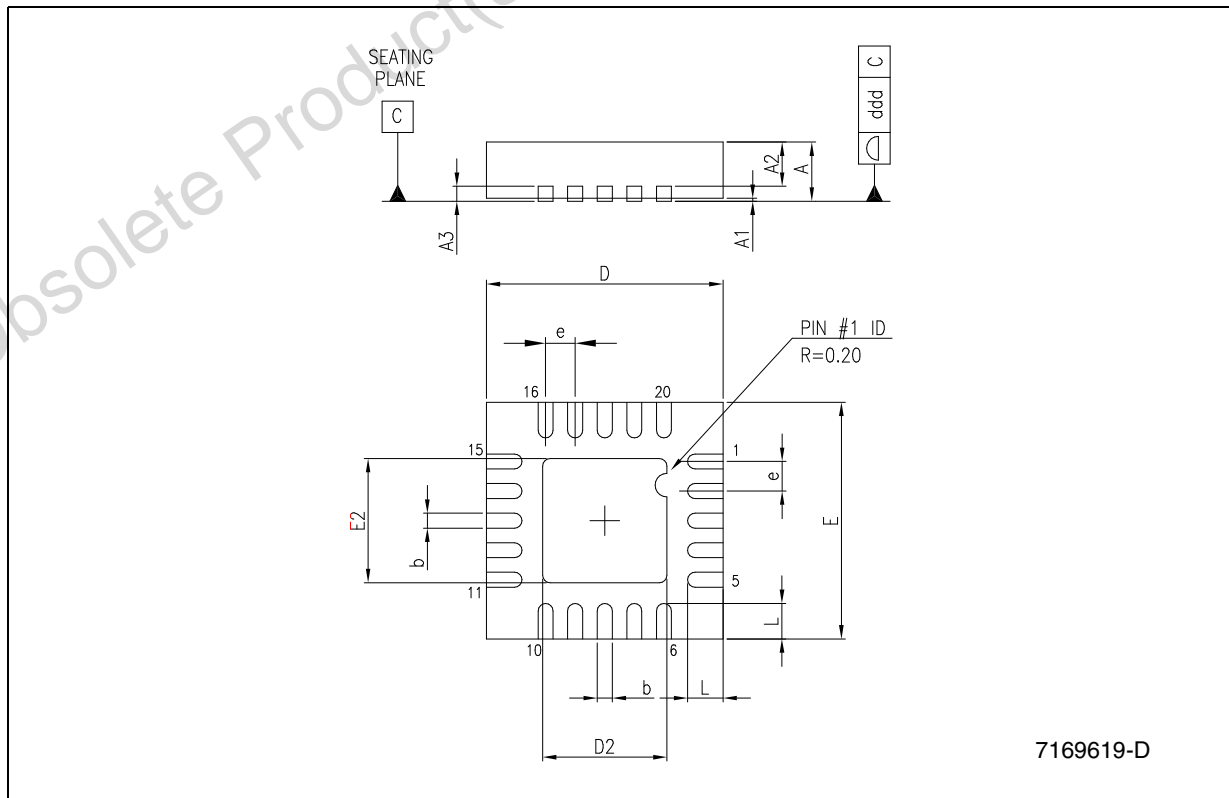

8 Revision history

Table 7. Revision history

Date	Revision	Changes
10-Nov-2005	1	First release.
19-Dec-2005	2	Document updating.
29-Jun-2006	3	The table 5 has been updated and add typical characteristics.
27-Jul-2006	4	Mistake on table 5 figure reference $T_{FL/TR}$ parameter.
18-Oct-2006	5	Text updates.
09-Feb-2007	6	Mistake value of I_O test condition $RM_{FLASH_MAX} = 500\Omega \implies 500k\Omega$ on Table 5 .

Please Read Carefully:

Information in this document is provided solely in connection with ST products. STMicroelectronics NV and its subsidiaries ("ST") reserve the right to make changes, corrections, modifications or improvements, to this document, and the products and services described herein at any time, without notice.

All ST products are sold pursuant to ST's terms and conditions of sale.

Purchasers are solely responsible for the choice, selection and use of the ST products and services described herein, and ST assumes no liability whatsoever relating to the choice, selection or use of the ST products and services described herein.

No license, express or implied, by estoppel or otherwise, to any intellectual property rights is granted under this document. If any part of this document refers to any third party products or services it shall not be deemed a license grant by ST for the use of such third party products or services, or any intellectual property contained therein or considered as a warranty covering the use in any manner whatsoever of such third party products or services or any intellectual property contained therein.

UNLESS OTHERWISE SET FORTH IN ST'S TERMS AND CONDITIONS OF SALE ST DISCLAIMS ANY EXPRESS OR IMPLIED WARRANTY WITH RESPECT TO THE USE AND/OR SALE OF ST PRODUCTS INCLUDING WITHOUT LIMITATION IMPLIED WARRANTIES OF MERCHANTABILITY, FITNESS FOR A PARTICULAR PURPOSE (AND THEIR EQUIVALENTS UNDER THE LAWS OF ANY JURISDICTION), OR INFRINGEMENT OF ANY PATENT, COPYRIGHT OR OTHER INTELLECTUAL PROPERTY RIGHT.

UNLESS EXPRESSLY APPROVED IN WRITING BY AN AUTHORIZED ST REPRESENTATIVE, ST PRODUCTS ARE NOT RECOMMENDED, AUTHORIZED OR WARRANTED FOR USE IN MILITARY, AIR CRAFT, SPACE, LIFE SAVING, OR LIFE SUSTAINING APPLICATIONS, NOR IN PRODUCTS OR SYSTEMS WHERE FAILURE OR MALFUNCTION MAY RESULT IN PERSONAL INJURY, DEATH, OR SEVERE PROPERTY OR ENVIRONMENTAL DAMAGE. ST PRODUCTS WHICH ARE NOT SPECIFIED AS "AUTOMOTIVE GRADE" MAY ONLY BE USED IN AUTOMOTIVE APPLICATIONS AT USER'S OWN RISK.

Resale of ST products with provisions different from the statements and/or technical features set forth in this document shall immediately void any warranty granted by ST for the ST product or service described herein and shall not create or extend in any manner whatsoever, any liability of ST.

ST and the ST logo are trademarks or registered trademarks of ST in various countries.

Information in this document supersedes and replaces all information previously supplied.

The ST logo is a registered trademark of STMicroelectronics. All other names are the property of their respective owners.

© 2007 STMicroelectronics - All rights reserved

STMicroelectronics group of companies

Australia - Belgium - Brazil - Canada - China - Czech Republic - Finland - France - Germany - Hong Kong - India - Israel - Italy - Japan - Malaysia - Malta - Morocco - Singapore - Spain - Sweden - Switzerland - United Kingdom - United States of America

www.st.com