



0.8-2.5 GHz

Wireless Band Power
Combiners / Dividers

- Wireless Communications PCS and Cellular Coverage
- Broadband – 0.8 to 2.5 GHz
- Complete Series – 2-Way thru 16-Way Models
- Sealed Versions Available
- High Isolation ≥ 20 dB,
Typical ≥ 26 dB Isolation
- Excellent Phase and Amplitude Balance

Specifications

Type N (F), 0.8 to 2.5 GHz, 30 W

FREQUENCY RANGE (GHz)	MODEL	CONNECTORS	BAND SEGMENTS (GHz)	VSWR (max.)		INSERTION LOSS (dB max.)	ISOLATION (dB min.)	AMPLITUDE BALANCE (dB max.)	PHASE BALANCE (max.)	AVERAGE POWER* (W max.)			WEIGHT	
				INPUT	OUTPUT					A	B	C	oz.	gr.
0.8-2.5	3372A-2	TYPE N (F)	0.8-1	1.40	1.40	0.3	22	0.2	3°	30	5	0.5	7.8	220
			1-2.5	1.40	1.40	0.6	22	0.2	3°	30	5	0.5		
0.8-2.5	3372A-3	TYPE N (F)	0.8-2.5	1.60	1.50	0.8	15	0.5	8°	30	5	0.5	20.1	570
0.8-2.5	3372A-4	TYPE N (F)	0.8-2.5	1.40	1.35	0.8	22	0.3	6°	30	5	0.5	22.9	650
0.8-2.5	3372A-6	TYPE N (F)	0.8-1	1.70	1.50	0.8	18	0.5	8°	30	5	0.5	60	1700
			1-2.5	1.80	1.60	1.0	18	0.7	10°	30	5	0.5		

* Average Power Rating into a load VSWR of (A) 1.2 to 1, (B) 2 to 1 and (C) ∞ VSWR

SMA (F), 0.8 to 2.5 GHz, 30 W

FREQUENCY RANGE (GHz)	MODEL	CONNECTORS	BAND SEGMENTS (GHz)	VSWR (max.)		INSERTION LOSS (dB max.)	ISOLATION (dB min.)	AMPLITUDE BALANCE (dB max.)	PHASE BALANCE (max.)	AVERAGE POWER* (W max.)			WEIGHT	
				INPUT	OUTPUT					A	B	C	oz.	gr.
0.8-2.5	4372-2	SMA (F)	0.8-1	1.35	1.30	0.3	25	0.2	3°	30	5	0.5	3.5	100
			1-2.5	1.35	1.30	0.5	25	0.2	3°	30	5	0.5		
0.8-2.5	4372A-3	SMA (F)	0.8-2.5	1.60	1.50	0.8	15	0.5	8°	30	5	0.5	6	170
0.8-2.5	4372A-4	SMA (F)	0.8-2.5	1.40	1.35	0.8	22	0.3	6°	30	5	0.5	8.8	250
0.8-2.5	4372A-6	SMA (F)	0.8-1	1.70	1.50	0.8	18	0.5	8°	30	5	0.5	17	482
			1-2.5	1.80	1.60	1.0	18	0.7	10°	30	5	0.5		
1.9-2.5	4162-8	SMA (F)	1.9-2.5	1.50	1.40	1.1	22	0.5	6°	30	5	0.5	17.6	500
1.9-2.5	4162-16	SMA (F)	1.9-2.5	1.60	1.40	1.2	19	0.8	10°	30	5	0.5	19.4	550
0.8-1	4152-8	SMA (F)	0.8-1	1.30	1.30	0.8	20	0.4	6°	30	5	0.5	22.9	650
0.8-1	4152-16	SMA (F)	0.8-1	1.30	1.30	1.5	20	0.6	10°	30	5	0.5	30	850

* Average Power Rating into a load VSWR of (A) 1.2 to 1, (B) 2 to 1 and (C) ∞ VSWR

Power Dividers

Outline Drawings

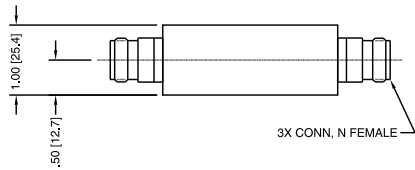
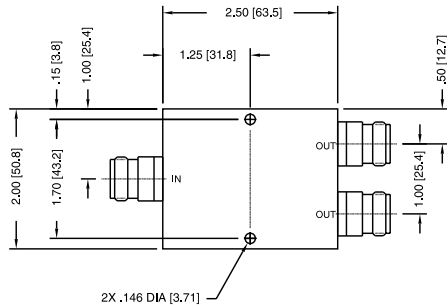

TOL:
XX $\pm .03$ [.5]
XXX $\pm .010$ [.25]

MODEL 3372A-2

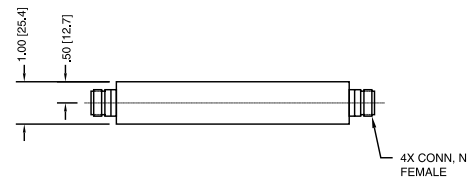
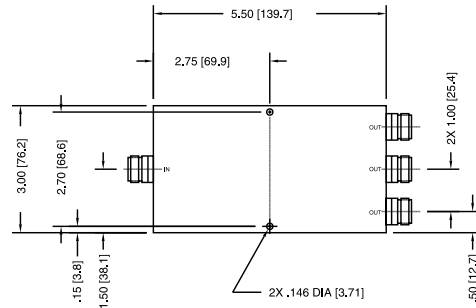

TOL:
XX $\pm .03$ [.5]
XXX $\pm .010$ [.25]

MODEL 3372A-3

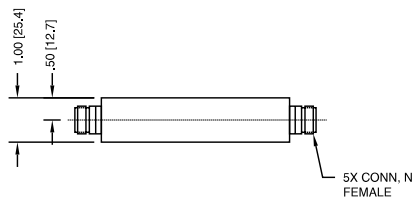
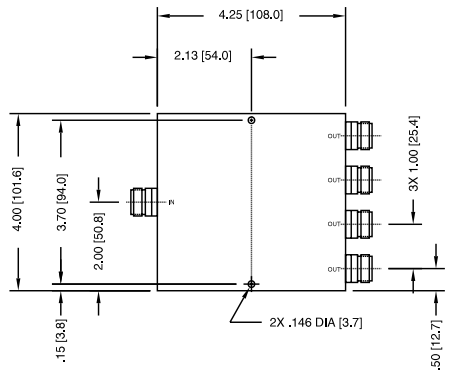

TOL:
XX $\pm .03$ [.5]
XXX $\pm .010$ [.25]

MODEL 3372A-4

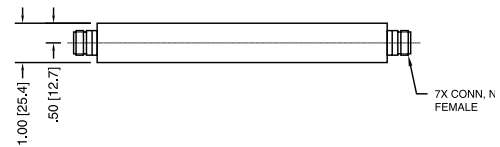
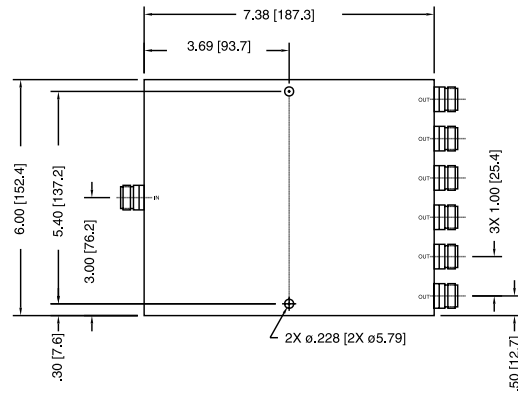

TOL:
XX $\pm .03$ [.5]
XXX $\pm .010$ [.25]

MODEL 3372A-6

Dimensions in inches (mm in parentheses), unless otherwise specified.
Connectors mate without interference per MIL-STD-348.

Outline Drawings

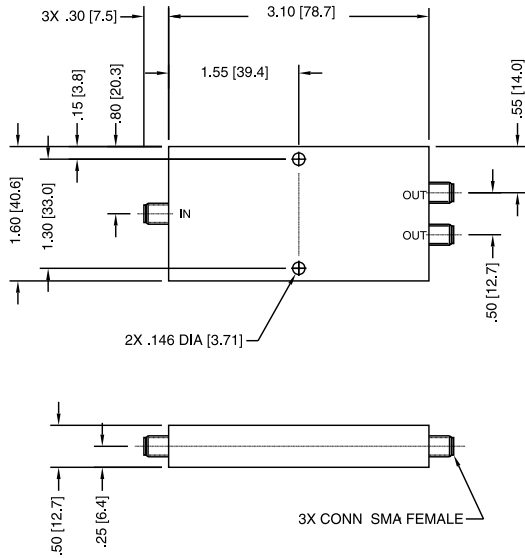

TOL:
XX ±.03 [.5]
XXX ±.010 [.25]

MODEL 4372-2

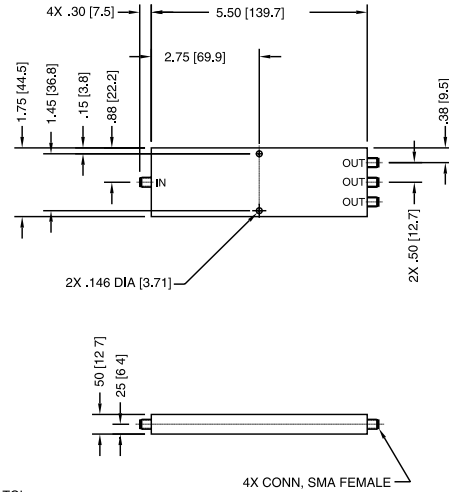

TOL:
X ±.03 [.5]
XXX ±.010 [.25]

MODEL 4372A-3

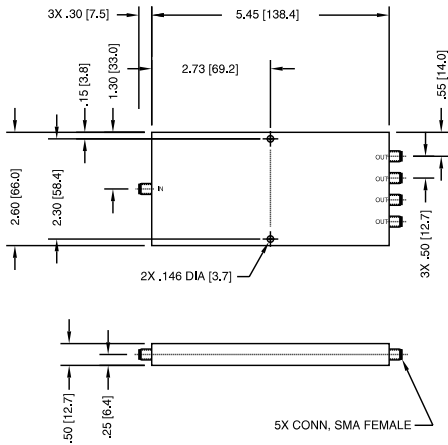

TOL:
XX ±.03 [.5]
XXX ±.010 [.25]

MODEL 4372A-4

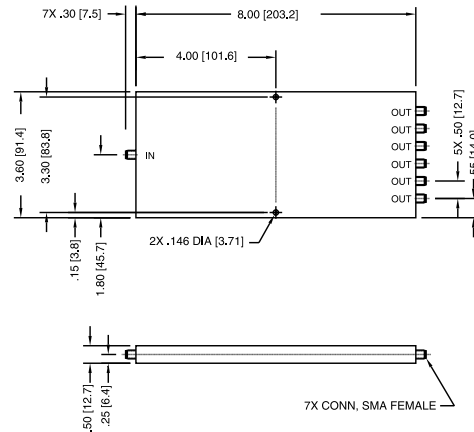

TOL:
XX ±.03 [.5]
XXX ±.010 [.25]

MODEL 4372A-6

Dimensions in inches (mm in parentheses), unless otherwise specified.
Connectors mate without interference per MIL-STD-348.

Power Dividers

Outline Drawings

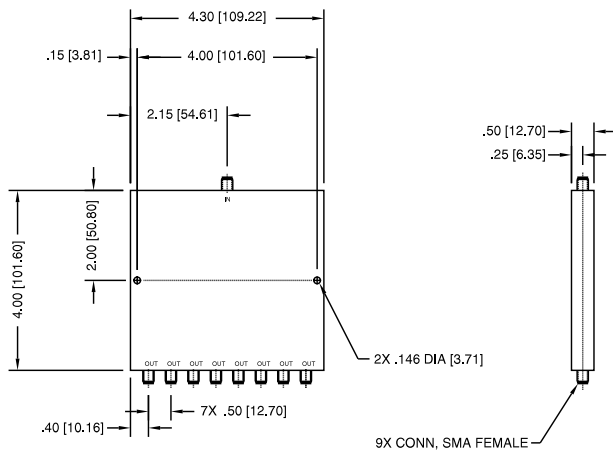

TOL:
XX ±.03 [.5]
XXX ±.010 [.25]

MODEL 4162-8

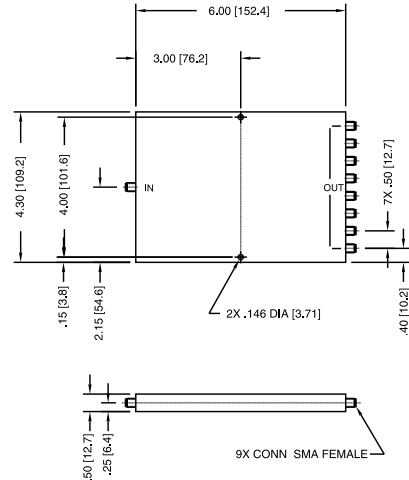

TOL:
XX ±.03 [.5]
XXX ±.010 [.25]

MODEL 4152-8

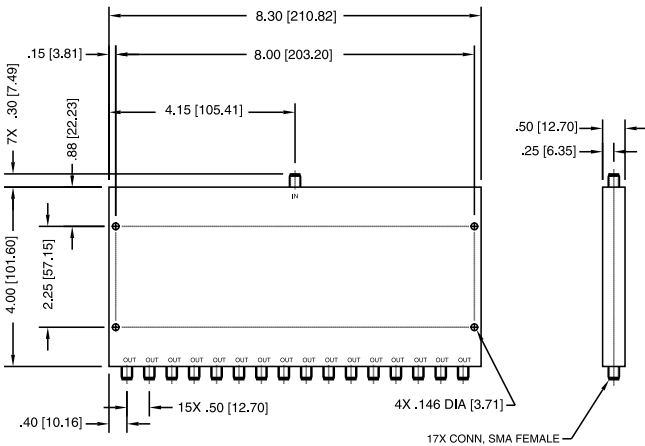

TOL:
XX ±.03 [.5]
XXX ±.010 [.25]

MODEL 4162-16

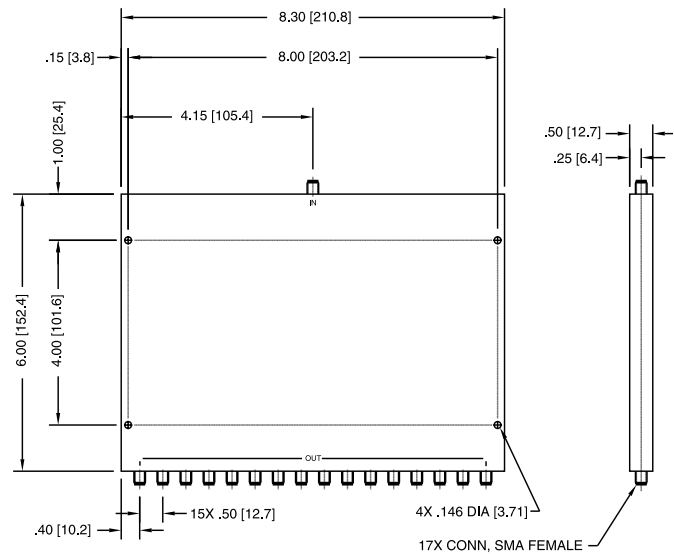

TOL:
XX ±.03 [.5]
XXX ±.010 [.25]

MODEL 4152-16

Dimensions in inches (mm in parentheses), unless otherwise specified.
Connectors mate without interference per MIL-STD-348.