



SPECIFICATION SHEET

SPECIFICATION SHEET NO.	N0924- SOT2301SSA1SHB
DATE	Sept. 24, 2021
REVISION	A2
DESCRIPTION	<p>SMD Plastic-Encapsulate MOSFETS, SOT-23 series, 3 pads</p> <p>SI2301S-2.3A Type, 20V P-Channel MOSFET</p> <p>Continuous Drain Current: -2.3A, Maximum Power Dissipation: 1.2 Watts</p> <p>Operating Temp. Range -50°C ~+150°C,</p> <p>Package in Tape/Reel, 3000pcs/Reel</p> <p>RoHS/RoHS III compliant</p>
CUSTOMER	
CUSTOMER PART NUMBER	
CROSS REF. PART NUMBER	
ORIGINAL PART NUMBER	MDD SI2301S-2.3A
PART CODE	SOT2301SSA1SHB

VENDOR APPROVE			
Issued/Checked/Approved			
DATE: Sept. 24, 2021			

CUSTOMER APPROVE	
DATE:	

SMD PLASTIC-ENCAPSULATE MOSFETS SOT-23 SERIES

MAIN FEATURE

- Trench FET Power MOSFET
- Continuous Drain Current 2.3A



APPLICATION

- Load Switch for Portable Devices
- DC/DC Converter

RFQ

[Request For Quotation](#)

PART CODE GUIDE

SOT23	01S	S	A1SHB
1	2	3	4

- 1) **SOT23**: SMD Plastic-Encapsulate MOSFETS, SOT-23 series, 3 pads
- 2) **01S**: Type code for Original part number SI2301S- 2.3A
- 3) **S**: Package code, Package in Tape/Reel, 3000pcs/Reel
- 4) **A1SHB**: Marking code for “A1sHB” on the case surface, Different Marking for different specification.

SMD PLASTIC-ENCAPSULATE MOSFETS SOT-23 SERIES

DIMENSION (Unit: Inch/mm)

Image for reference

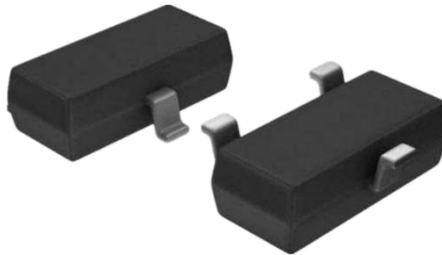

Marking: A1sHB

SOT-23

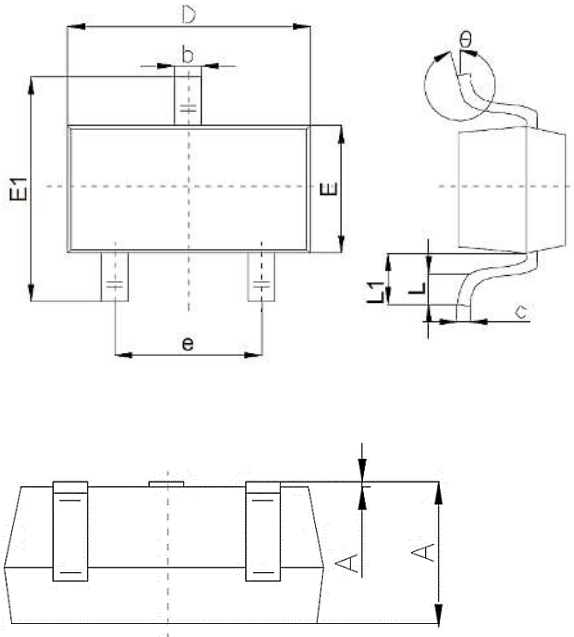

Symbol	Value (mm)		
	Min.	Typ.	Max.
A	1.0		1.4
A1			0.10
b	0.35		0.50
c	0.10		0.20
D	2.70	2.90	3.10
E	1.40		1.60
E1	2.40		2.80
e		1.9	
L	0.10		0.30
L1	0.40		
θ	0°		10°

Recommend Pad Layout
(Tol.: +/-0.05mm)

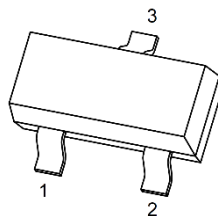
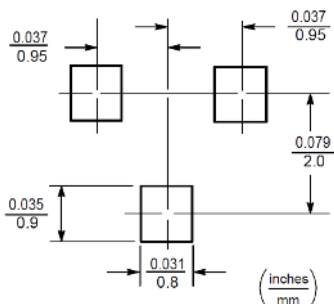

1. Gate
2. Source
3. Drain

Equivalent Circuit Diagram

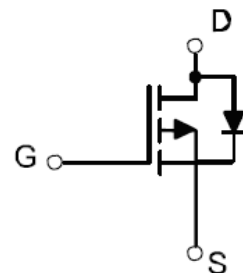

SMD PLASTIC-ENCAPSULATE MOSFETS SOT-23 SERIES
20V P-CHANNEL MODE MOSFET

V (BR)DSS	R DS(on) Typical	I D MAX
-20V	125 mΩ@4.5V	-2.3A
	140 mΩ@3.3V	-2.3A

MECHANICAL DATA

V(BR)DSS	Terminals	Polarity	Mounting Position	Weight per piece
JEDEC SOT-23 molded plastic body	Matte tin plated	Polarity symbol marking on case	Any	0.00019 Ounce, 0.00591 grams

MAX. RATINGS & THERMAL CHARACTERISTICS AT Ta=25 °C (unless otherwise specified)

Parameter	SYMBOL	VALUE	UNITS	
		LIMIT		
Drain-Source Voltage	V DS	-20	V	
Gate-Source Voltage	V GS	+/-10	V	
Continuous Drain Current	I D	@ T A = 25 °C	-2.3	A
		@ T A = 70 °C	-2.5	
Pulsed Drain Current (See Note 1)	I DM	-12	A	
Power Dissipation (See Note 2)	P D	@ T A = 25 °C	1.2	W
		@ T A = 70 °C	0.9	
Junction-to-Ambient Thermal Resistance (PCB mounted)	R thJA	100	°C/W	
Junction Temperature	T J	-50 ~ +150	°C	
Storage Temperature Range	T STG	-50 ~ +150		

Notes

- 1) Pulse width limited by maximum junction temperature.
- 2) Surface Mounted on FR4 Board, t ≤5 sec.

SMD PLASTIC-ENCAPSULATE MOSFETS SOT-23 SERIES
MOSFET ELECTRICAL CHARACTERISTICS AT Ta=25 °C (unless otherwise specified)

Parameter	SYMBOLS	VALUE			UNIT	Condition
		Min.	Typ.	Max.		
Drain-source Breakdown Voltage	V (BR) DSS	-20			V	V GS=0V I D= -250μA
Gate-source threshold voltage	V GS(th)	-0.4	-0.6	-1.0	V	V DS=VGS, I D=-250μA
Zero Gate Voltage Drain Current	I DSS			-1.0	μA	V DS=-20V, V GS=0V
Gate-source Leakage Current	I GSS			+/-100	nA	V GS=±10V, V DS=0V
Forward transconductance (see Note 1)	g fs		4.0		S	V DS=-5V, I D=-2.8A
Drain-Source On-State Resistance (see Note 1)	R DS(ON)		70	90	mΩ	V GS= -4.5V, I D= -3.0A
			78	100	mΩ	V GS=-3.3V, I D= -2.0A

DYNAMIC ELECTRICAL CHARACTERISTICS (See Note 2)

Parameter	SYMBOLS	VALUE			UNIT	Condition
		Min.	Typ.	Max.		
Input Capacitance	C iss		330		pF	V DS= -10V V GS=0V f =1MHz
Output Capacitance	C oss		50			
Reverse Transfer Capacitance	C rss		45			
Total Gate Charge	Q g		6.6		nC	V DS =-10V, V GS =-4.5V I D =-3A
Gate Source Charge		Q gs		0.8		
Gate Drain Charge	Q gd		1.4			

SMD PLASTIC-ENCAPSULATE MOSFETS SOT-23 SERIES
SWITCHING CHARACTERISTICS

Parameter	SYMBOLS	VALUE			UNIT	Condition
		Min.	Typ.	Max.		
Turn on Delay Time	$t_{d(on)}$		11		ns	$V_{DD} = -10V$ $I_D = 3.0A$ $R_L = 10\Omega$ $V_{GEN} = -4.5V$ $R_g = 3.3\Omega$
Rise Time	t_r		12			
Turn Off Delay Time	$t_{d(off)}$		18			
Fall Time	t_f		30			

SOURCE DRAIN DIODE CHARACTERISTIC

Parameter	SYMBOLS	VALUE			UNIT	Condition
		Min.	Typ.	Max.		
Continuous source-drain diode current	I_S			-1.5	A	$T_C = 25^\circ C$
Body diode voltage	V_{SD}		-0.85	-1.2	V	$I_S = 2.0A$

Note:

- 1) Pulse test: pulse width $\leq 300\mu s$, duty cycle $\leq 2\%$
- 2) Guaranteed by design, not subject to production testing

SMD PLASTIC-ENCAPSULATE MOSFETS SOT-23 SERIES
RELIABILITY

Number	Experiment Items	Experiment Method And Conditions	Reference Documents
1	Solder Resistance Test	Test 260°C± 5°C for 10 ± 2 sec. Immerse body into solder 1/16" ± 1/32"	MIL-STD-750D METHOD-2031.2
2	Solderability Test	230°C ±5°C for 5 sec.	MIL-STD-750D METHOD-2026.1 0
3	Pull Test	1 kg in axial lead direction for 10 sec.	MIL-STD-750D METHOD-2036.4
4	Bend Test	0.5Kg Weight Applied To Each Lead, Bending Arcs 90 °C ± 5 °C For 3 Times	MIL-STD-750D METHOD-2036.4
5	High Temperature Reverse Bias Test	TA=100°C for 1000 Hours at VR=80% Rated VR	MIL-STD-750D METHOD-1038.4
6	Forward Operation Life Test	TA=25°C Rated Average Rectified Current	MIL-STD-750D METHOD-1027.3
7	Intermittent Operation Life Test	On state: 5 min with rated IRMS Power Off state: 5 min with Cool Forced Air. On and off for 1000 cycles.	MIL-STD-750D METHOD-1036.3
8	Pressure Cooker Test	15 PSIG, TA=121°C, 4 hours	MIL-S-19500 APPENOIXC
9	Temperature Cycling Test	-55°C~+125°C; 30 Minutes For Dwelled Time 5 minutes for transferred time. Total: 10 cycles.	MIL-STD-750D METHOD-1051.7
10	Thermal Shock Test	0°C for 5 minutes., 100°C for 5minutes, Total: 10 cycles	MIL-STD-750D METHOD-1056.7
11	Forward Surge Test	8.3ms Single Sale Sine-wave One Surge.	MIL-STD-750D METHOD-4066.4
12	Humidity Test	TA=65°C, RH=98% for 1000 hours.	MIL-STD-750D METHOD-1021.3
13	High Temperature Storage life Test	150°C for 1000 Hours	MIL-STD-750D METHOD-1031.5

SMD PLASTIC-ENCAPSULATE MOSFETS SOT-23 SERIES

SUGGESTED REFLOW PROFILE (For Reference Only)

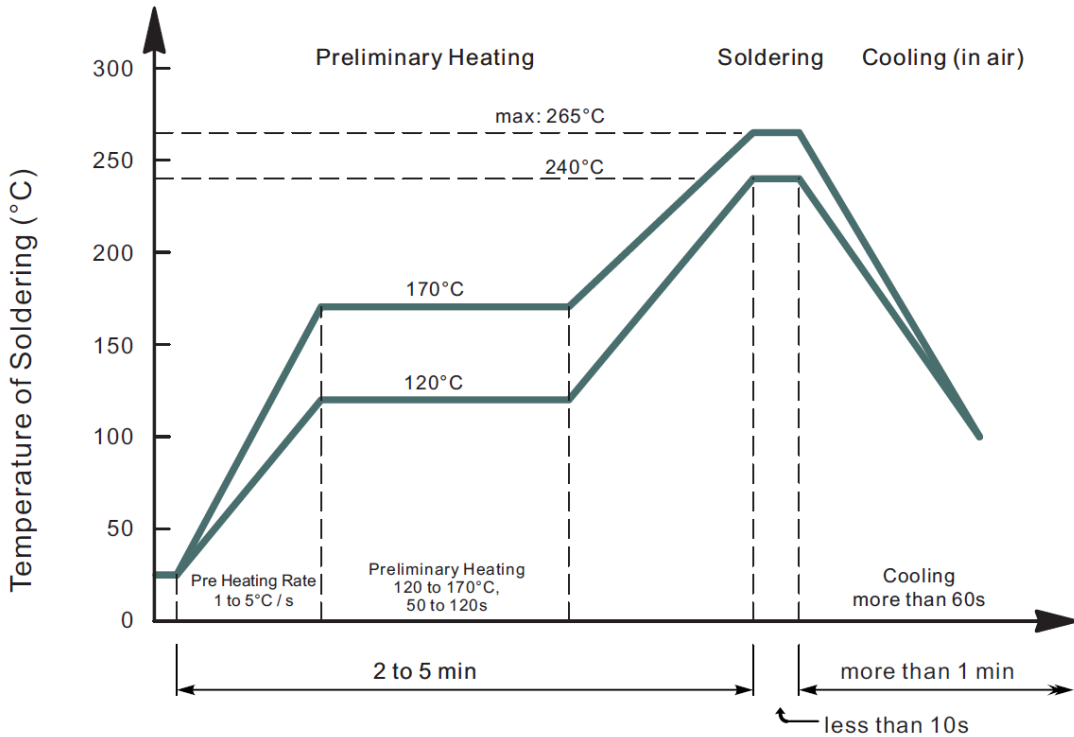

- Recommended peak temperature is over 245°C, If peak temperature is below 245 °C, you may adjust the following parameters; time length of peak temperature (longer), time length of soldering (longer), thickness of solder paste (thicker)
- Welding shall not exceed 2 times
- Remark: lead free solder paste (96.5 sn/3.0 Ag/0.5Cu)

SMD PLASTIC-ENCAPSULATE MOSFETS SOT-23 SERIES

RATINGS AND CHARACTERISTIC CURVES (For Reference Only)

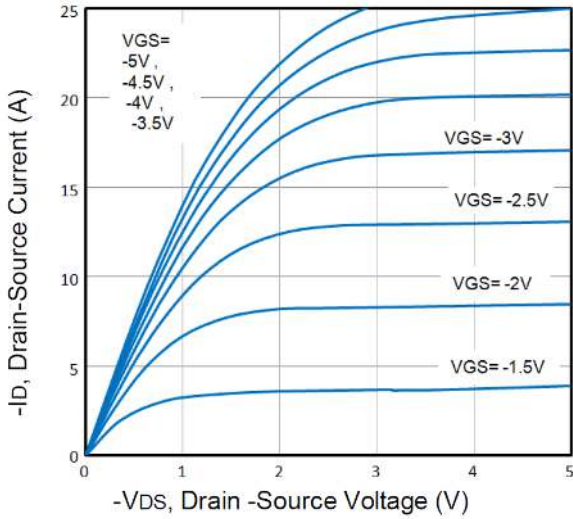

Fig1. Typical Output Characteristics

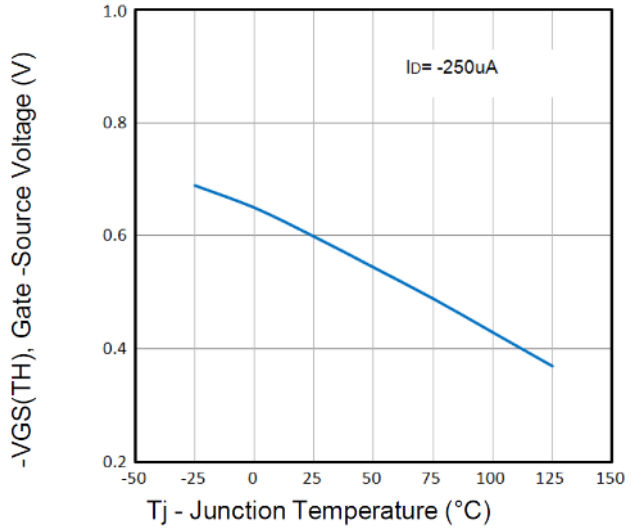

Fig2. Normalized Threshold Voltage Vs. Temperature

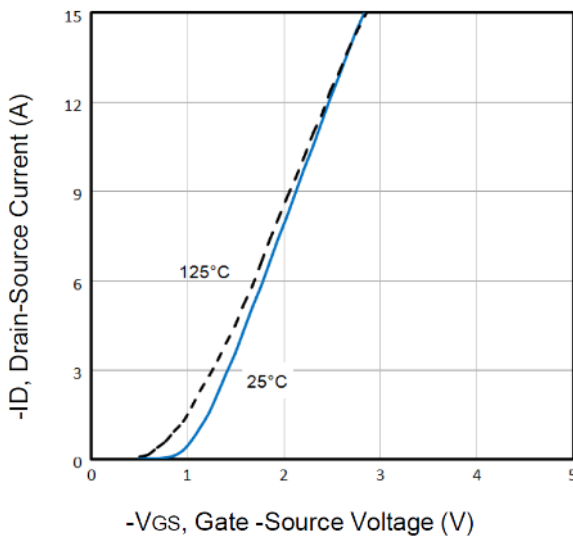

Fig3. Typical Transfer Characteristics

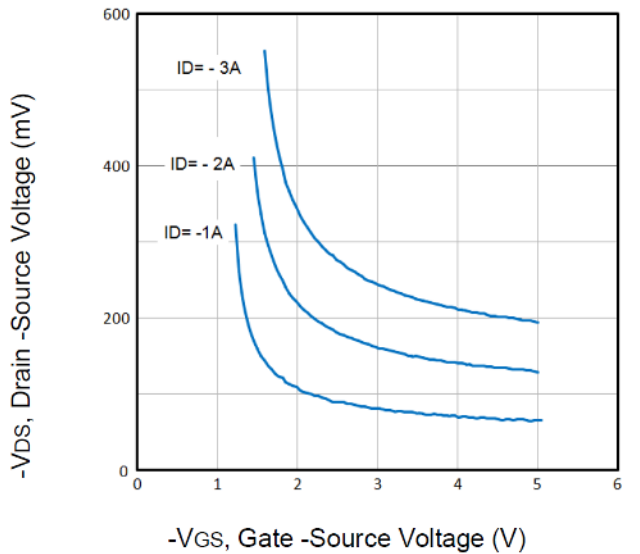

Fig4. Drain-Source Voltage vs Gate-Source Voltage

SMD PLASTIC-ENCAPSULATE MOSFETS SOT-23 SERIES

RATINGS AND CHARACTERISTIC CURVES (For Reference Only)

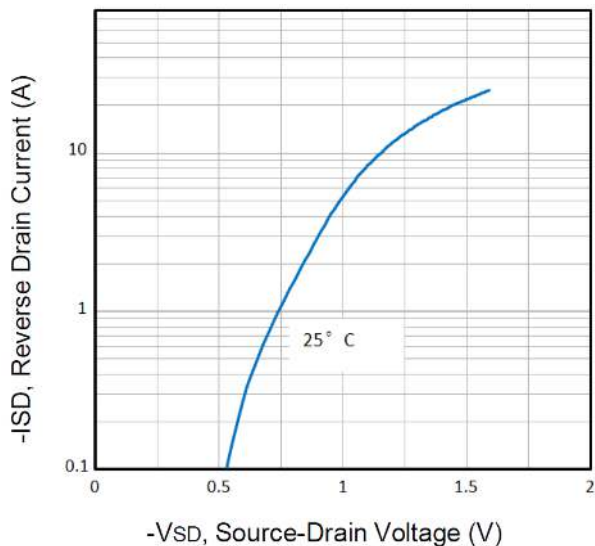

Fig5. Typical Source-Drain Diode Forward Voltage

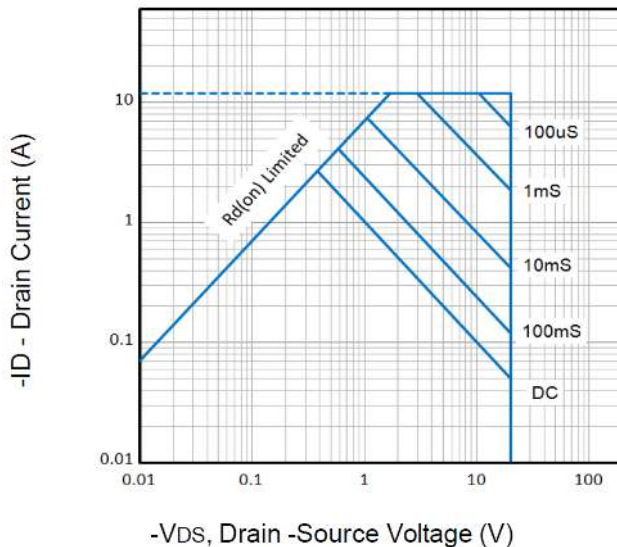

Fig6. Maximum Safe Operating Area

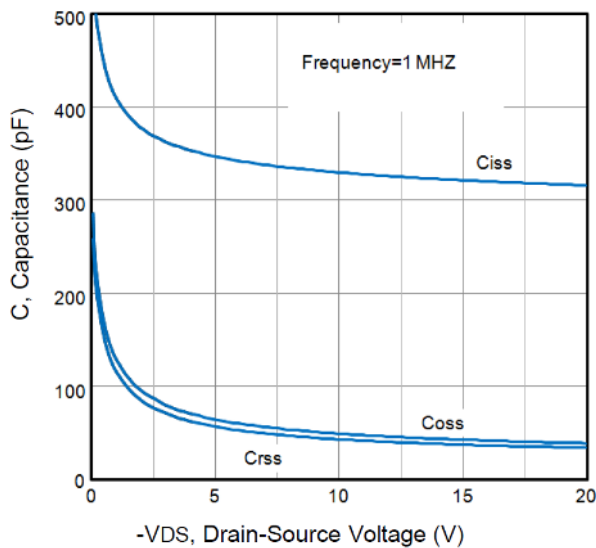

Fig7. Typical Capacitance Vs. Drain-Source Voltage

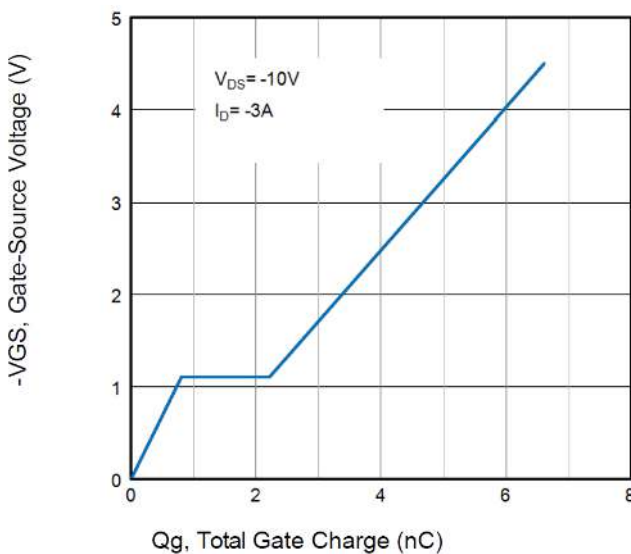

Fig8. Typical Gate Charge Vs. Gate-Source Voltage

SMD PLASTIC-ENCAPSULATE MOSFETS SOT-23 SERIES

RATINGS AND CHARACTERISTIC CURVES (For Reference Only)

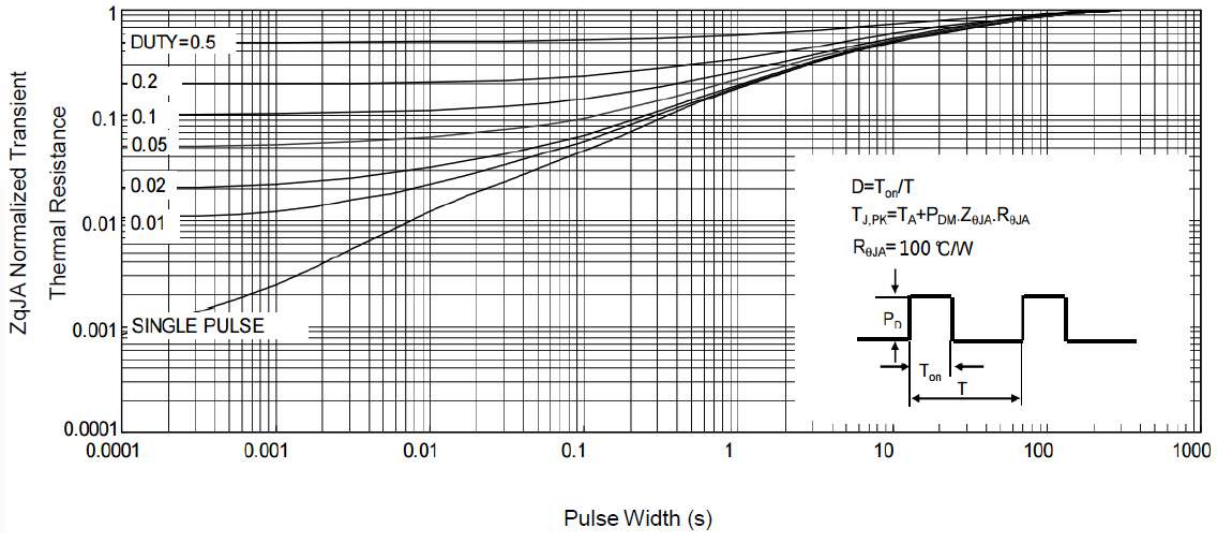

Fig9. Normalized Maximum Transient Thermal Impedance

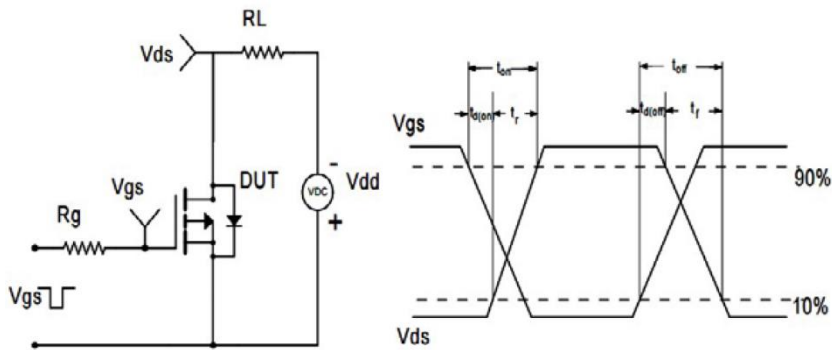
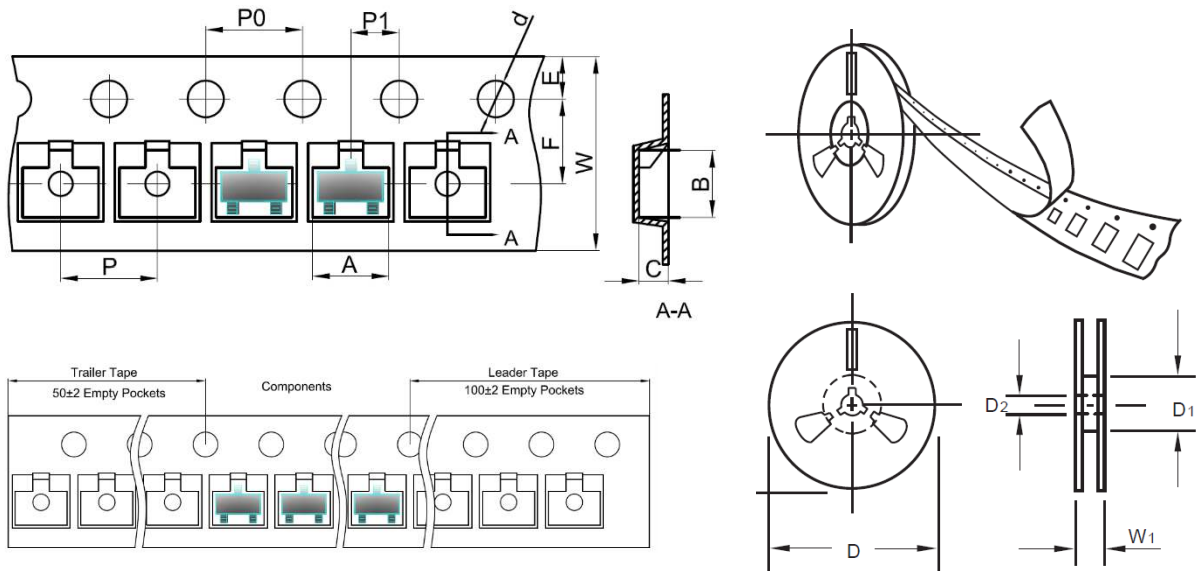

Fig10. Switching Time Test Circuit and waveforms

SMD PLASTIC-ENCAPSULATE MOSFETS SOT-23 SERIES

TAPE/REEL (Unit: mm)

All Devices are packed in accordance with EIA standard RS-481-A and specifications.



Item	Symbol	Tolerance	SOT-23
Carrier width	A	0.1	3.15
Carrier Length	B	0.1	2.77
Carrier Depth	C	0.1	1.22
Sprocket hole	d	0.05	1.55
7"Reel outside diameter	D	2.0	178.00
7"Reel inner diameter	D1	Min.	54.4
Feed hole diameter	D2	0.5	13.00
Sprocket hole position	E	0.1	1.75
Punch hole position	F	0.1	3.50
Punch hole pitch	P	0.1	4.00
Sprocket hole pitch	P0	0.1	4.00
Embossment center	P1	0.1	2.00
Overall tape thickness	T	0.1	0.25
Tape width	W	0.3	8.00
Reel width	W1	1.0	19.50

SMD PLASTIC-ENCAPSULATE MOSFETS SOT-23 SERIES

PACKAGE

Case Code	Reel Size	MPQ (pcs)	Component Spacing (mm)	Qty. Per Box (pcs)	Inner Box L*W*H (mm)	Reel Size (mm)	Carton size L*W*H (mm)	Qty. Per Carton (pcs)	G. W (kg)
SOT-23	7"	3,000		45,000	212*207*207	178	430*430*230	180,000	6.5

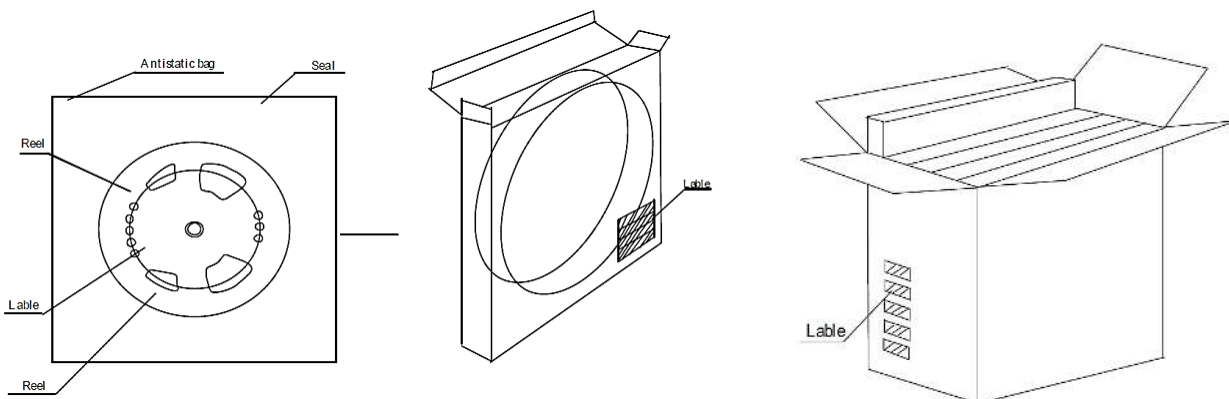

DISCLAIMER

NextGen Component, Inc. reserves the right to make changes to the product(s) and or information contained herein without notice. No liability is assumed as a result of their use or application. No rights under any patent accompany the sale of any such product(s) or information