

THIS DRAWING IS UNPUBLISHED. RELEASED FOR PUBLICATION ,19 .
 © COPYRIGHT 19 BY AMP INCORPORATED. ALL INTERNATIONAL RIGHTS RESERVED.

LOC		DIST		REVISIONS				DATE	APPD
CE	16	P	F	ZONE	LTR	DESCRIPTION			
				K		REVISE PER 0A00-0632-02	24JUL02	KG/SB	

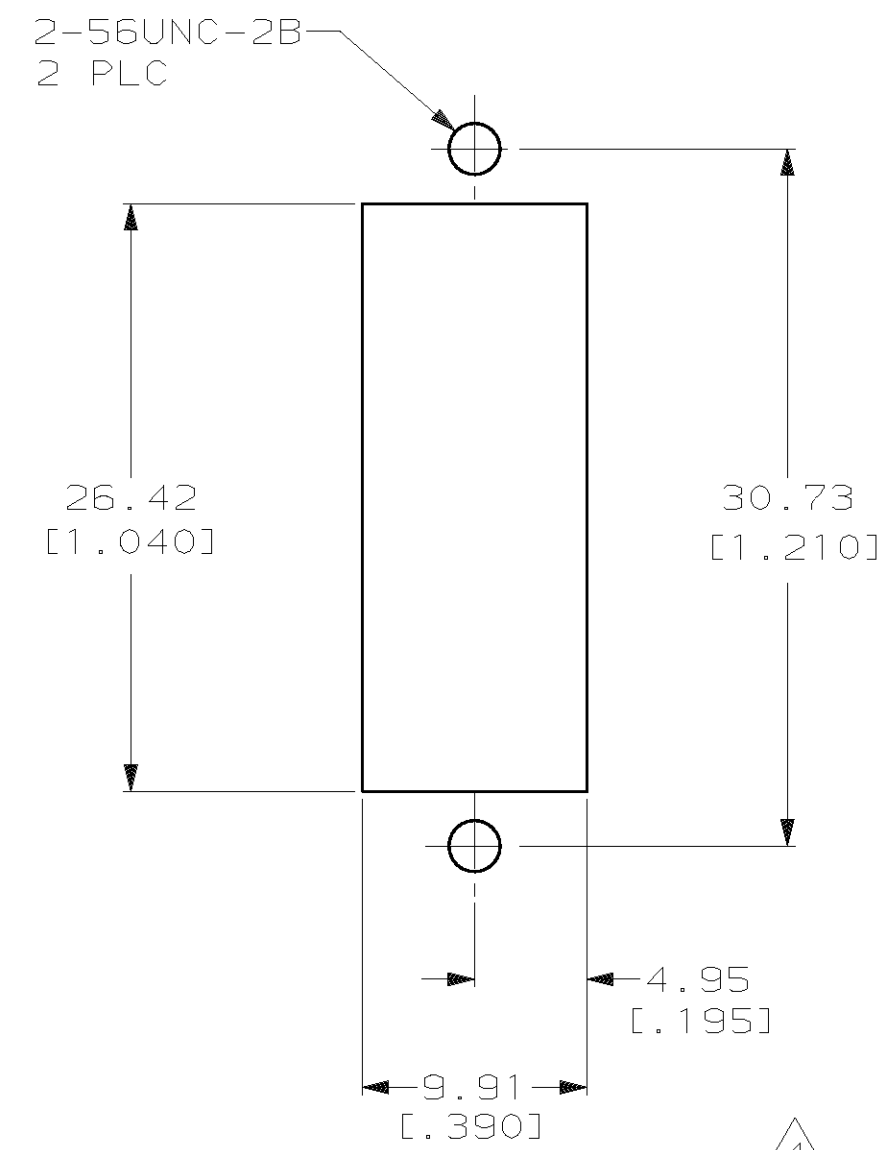
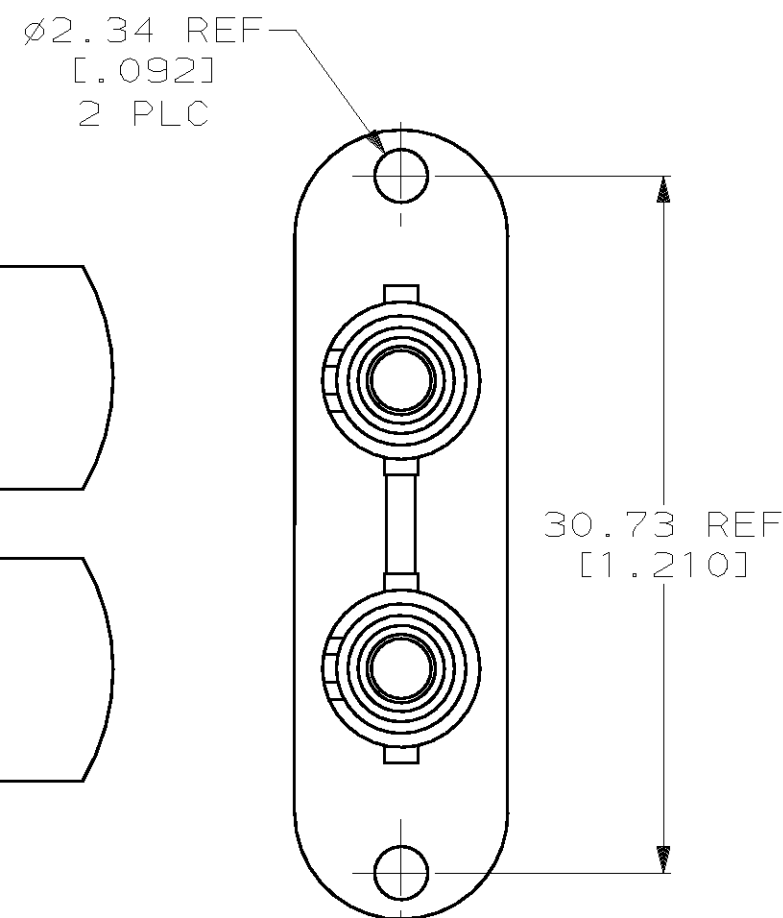
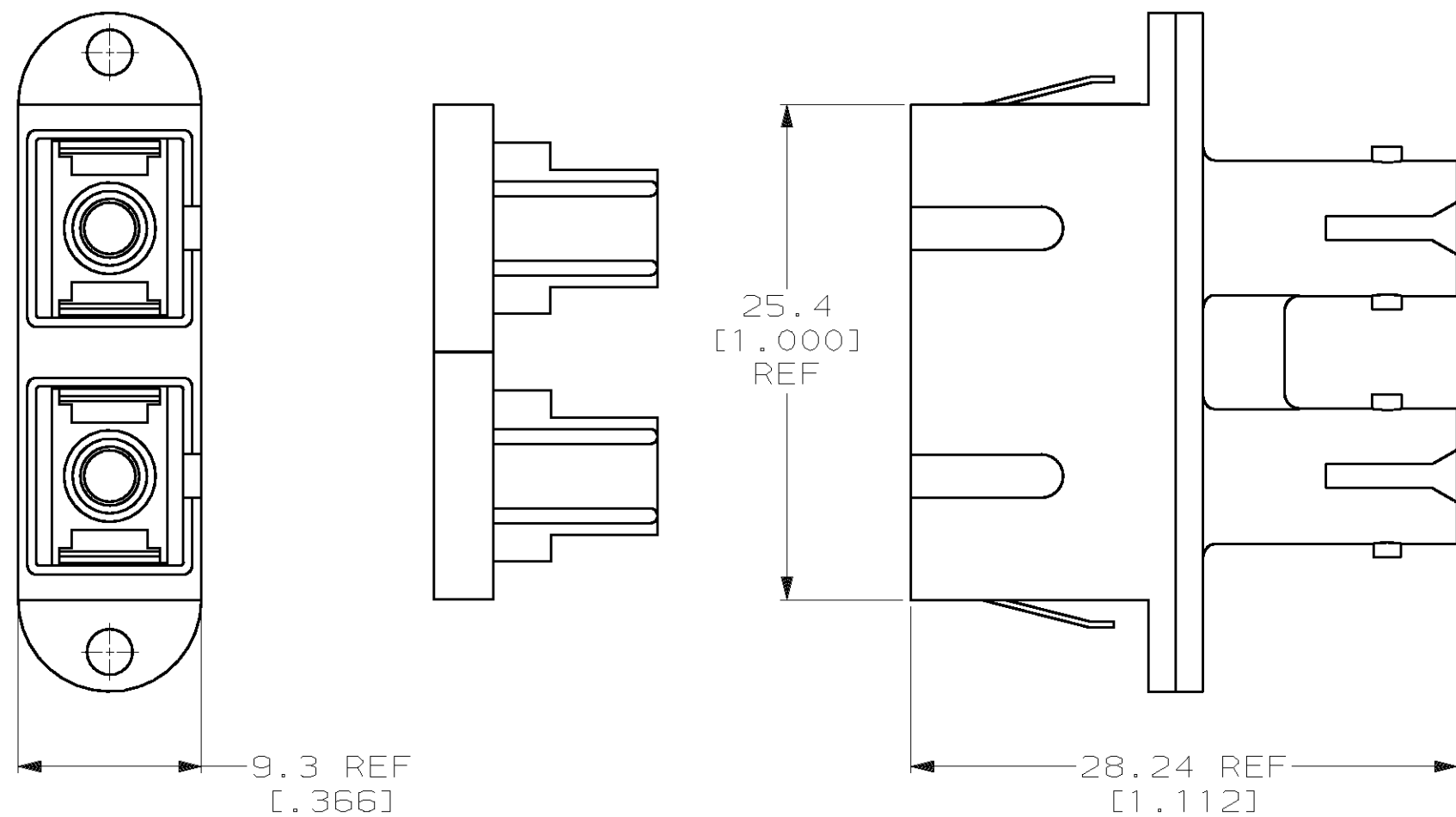

- 1 MATERIAL:
 HOUSINGS - PPE+PS, UL 94 V-0*, SEE DASH NUMBERS FOR COLOR
 RETENTION CLIP - STAINLESS STEEL
 SLEEVE - SEE TABLE
 CONNECTOR RETAINER - PEI-GF30, COLOR: BLACK, UL 94 V-0*
 DUST COVER, SC - TPE, COLOR: BLACK, UL 94 V-0*
 DUST COVER, ST - PVC, COLOR: RED, NON-FR
 *RATED AT QUALIFYING THICKNESS

2. DIMENSIONS IN [] ARE IN INCHES.
 3 BULK PACKAGE, 50 PIECES.
 4 RECOMMENDED PANEL THICKNESS 1.60±.10 [.063±.004].
 5 NO AMP LOGO

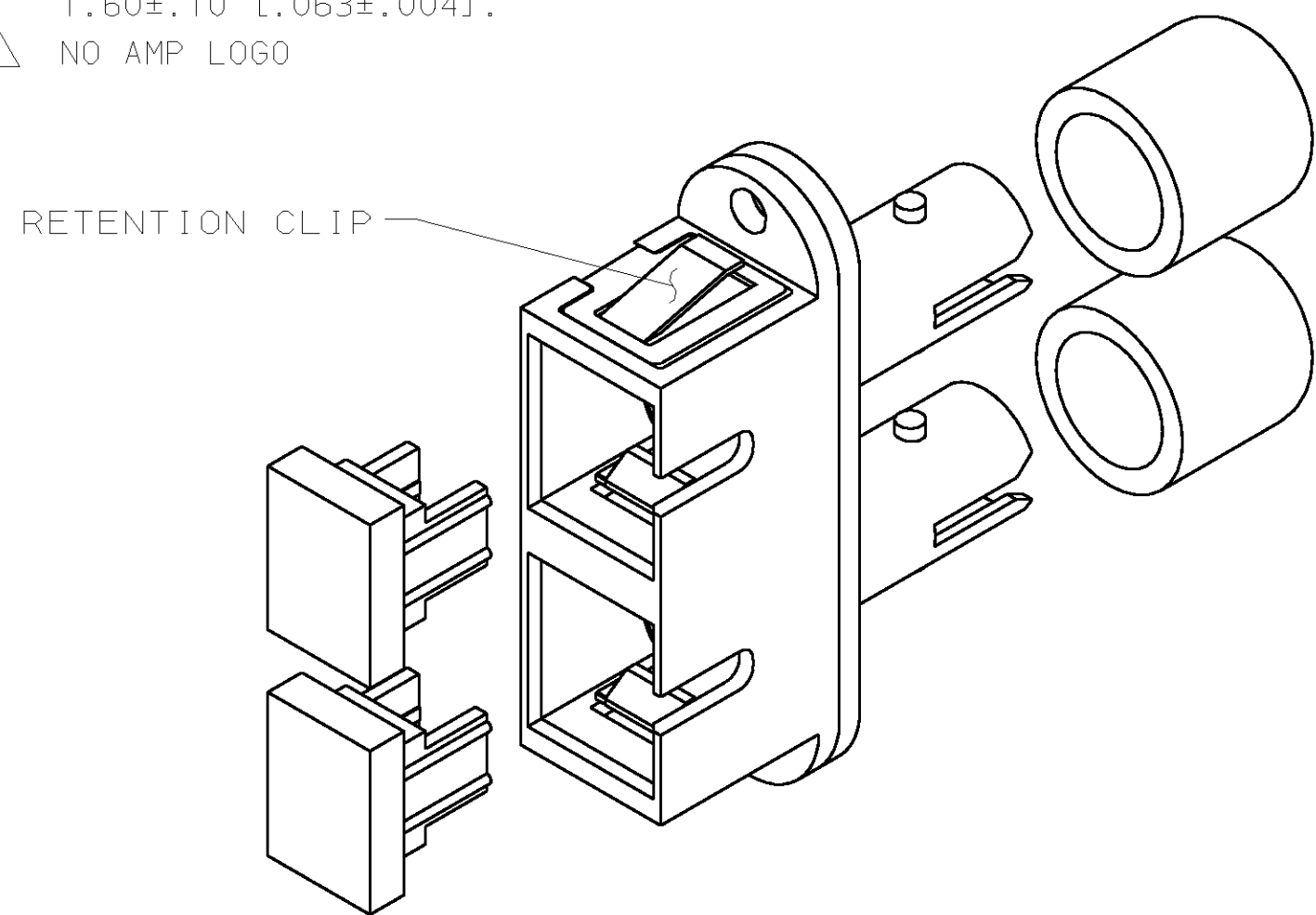

5	RETENTION CLIP	BEIGE	PHOSPHOR BRONZE	2-503137-0
5	RETENTION CLIP	BLUE	ZIRCONIA	1-503137-9
	NONE	BLACK	PHOSPHOR BRONZE	1-503137-7
3	NONE	LT ALMOND	ZIRCONIA	1-503137-6
	NONE	LT ALMOND	ZIRCONIA	1-503137-5
3	NONE	LT ALMOND	PHOSPHOR BRONZE	1-503137-4
	NONE	LT ALMOND	PHOSPHOR BRONZE	1-503137-3
3	RETENTION CLIP	BEIGE	ZIRCONIA	1-503137-2
3	RETENTION CLIP	BLUE	ZIRCONIA	1-503137-1
3	RETENTION CLIP	BLACK	ZIRCONIA	1-503137-0
3	RETENTION CLIP	BEIGE	PHOSPHOR BRONZE	503137-9
3	RETENTION CLIP	BLUE	PHOSPHOR BRONZE	503137-8
3	RETENTION CLIP	BLACK	PHOSPHOR BRONZE	503137-7
	RETENTION CLIP	BEIGE	ZIRCONIA	503137-6
	RETENTION CLIP	BLUE	ZIRCONIA	503137-5
	RETENTION CLIP	BLACK	ZIRCONIA	503137-4
	RETENTION CLIP	BEIGE	PHOSPHOR BRONZE	503137-3
	RETENTION CLIP	BLUE	PHOSPHOR BRONZE	503137-2
	RETENTION CLIP	BLACK	PHOSPHOR BRONZE	503137-1
	INCLUDED HARDWARE	COLOR	ALIGNMENT SLEEVE	PART NO

DO NOT SCALE PRINT. UNLESS SPECIFIED DIMENSIONS IN INCHES TOLERANCES ON : 2 PLC DEC ± - 3 PLC DEC ± - ANGLES ± -	DR 10-6-92 R R SCHAFFER	AMP INCORPORATED Harrisburg, Pa. 17105	
MATERIAL 1	CHK 10-6-92 D STAKEM		
FINISH -	APPD 10-6-92 K MONROE	NAME	
	APPD 10-6-92 R WEBER	ADAPTER, DUPLEX AMP SC - ST STYLE	
	PRODUCT SPEC -	SIZE C	FSCM NO 00779
	APPLICATION SPEC -	DRAWING NO 503137	
	WEIGHT -	SCALE 3:1	SHEET 1 OF 1

METRIC